

**ISTRUZIONE MONTAGGIO CON ROSETTA 52x10 TONDA E QUADRA (MONTAGGIO CON VITI LEGNO).
INSTALLATION SCHEME FOR ROSE 52x10 ROUND AND SQUARE (WOOD SCREWS)**

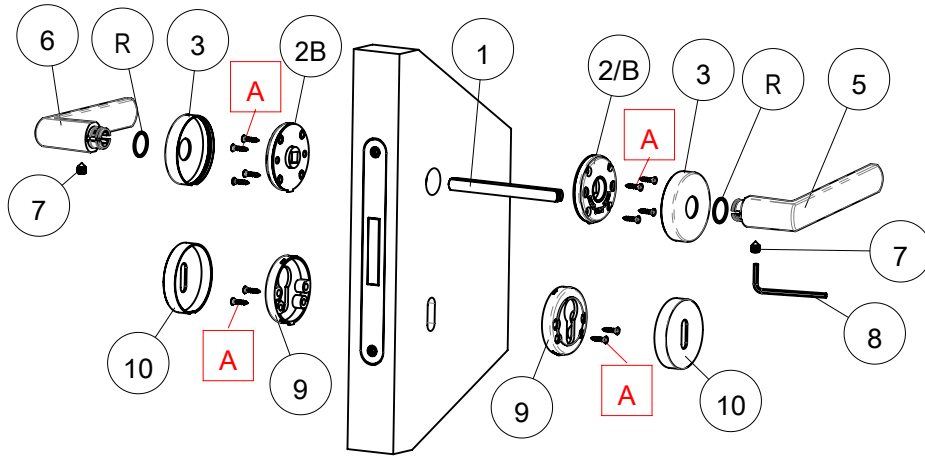

1	FERRO QUADRO	SQUARE SPINDLE
2/B	SOTTO ROSETTA CON MOLLA BIDIREZIONALE	SPRING INNER ROSE
3	ROSETTA	ROSE COVER
5	IMPUGNATURA DESTRA	RIGHT HAND LEVER
6	IMPUGNATURA SINISTRA	LEFT HAND LEVER
7	VITE GRANO PER FISSAGGIO IMPUGNATURE	GRUB SCREW
8	CHIAVE ESAGONALE PER VITE GRANO	ALLEN KEY
9	SOTTO BOCCHETTA	INNER ROSE BASE FOR ESCUTCHEON
10	BOCCHETTA PATENT / YALE	KEYHOLE /EURO CYLINDER PROFILE ESCUTCHEON COVER
R	RONDELLA NYLON	NYLON WASHER
A	VITI PER FISSAGGIO SOTTO ROSETTE/SOTTO BOCCHETTE	SCREW FIXINGS
D	DIMA PER CENTRATURA VITI DI MONTAGGIO SOTTO ROSETTA	TEMPLATE FOR CENTRING THE SCREW FIXINGS OF THE INNER ROSES

Fig.01: INSERIRE NELLA SERRATURA IL FERRO QUADRO (1) MANTENENDO LA SCANALATURA VERSO IL BASSO.
Fig.02: FARE ATTENZIONE A MANTENERE LA STESSA SPORGENZA DEL FERRO QUADRO (1) SU ENTRAMBI I LATI DEL BATTENTE.
Fig.03: RISPETTARE LA CORRETTA PERPENDICOLARITA' DEL FERRO QUADRO (1) RISPETTO AL PIANO DELLA PORTA.

Fig.01: PLACE THE SQUARE SPINDLE (1) THROUGH THE LOCK WITH THE GROOVE FACING DOWN.
Fig.02: PAY ATTENTION TO KEEP THE SAME PROJECTION OF THE SQUARE SPINDLE (1) ON BOTH SIDES OF THE DOOR LEAF.
Fig.03: KEEP THE CORRECT PERPENDICULARITY OF THE SQUARE SPINDLE (1) WITH RESPECT TO THE DOOR PLANE.

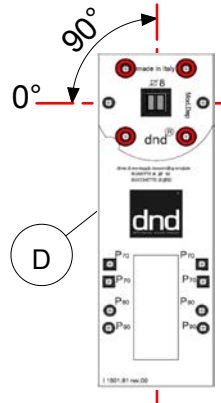
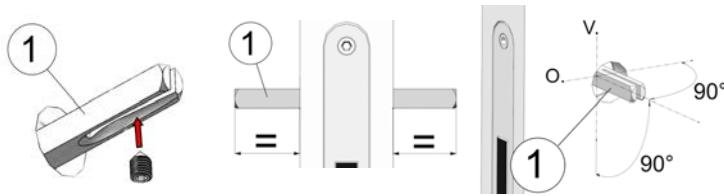

INSERIRE LA DIMA (D) SUL FERRO QUADRO (1) E SEGNARE LA POSIZIONE DELLE VITI DI MONTAGGIO.

SLIDE THE TEMPLATE (D) ON THE SQUARE SPINDLE (1) ADHERING TO THE DOOR LEAF AND MARK THE POSITION OF THE SCREW FIXINGS.

FISSARE LE SOTTO ROSETTE (2) CON LE VITI FORNITE RISPETTANDO LA POSIZIONE INFERIORE DELLA TACCA DI POSIZIONAMENTO ROSETTA, APPLICARE LA ROSETTA (3).

FIX THE SPRING INNER ROSE (2) BY USING THE PROVIDED SCREWS, FOLLOWING THE LOWER POSITION OF THE INNER ROSES NOTCH, APPLY THE ROSE COVERS (3).



TACCA INFERIORE
NOTCH FACING DOWN

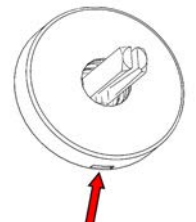

TACCA INFERIORE
NOTCH FACING DOWN

FISSARE LE SOTTO BOCCHETTE (9) CON LE VITI FORNITE RISPETTANDO LA POSIZIONE DELLA TACCA INFERIORE ABBINAMENTO BOCCHETTA, APPLICARE LA BOCCHETTA (10).

FIX THE NYLON INNER ROSE BASE (9) BY USING THE PROVIDED SCREWS, FOLLOWING THE LOWER POSITION OF THE INNER NYLON ROSE NOTCH, APPLY KEY HOLE /EURO CYLINDER PROFILE ESCUTCHEON COVER (10) BY PRESSURE.



TACCA INFERIORE
NOTCH FACING DOWN

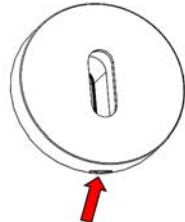

TACCA INFERIORE
NOTCH FACING DOWN

INSERIRE SUL COLLETTA DELL'IMPUGNATURA LA RONDELLA IN NYLON (4).

PLACE THE NYLON WASHER (4) ON THE COLLAR OF THE HANDLE.

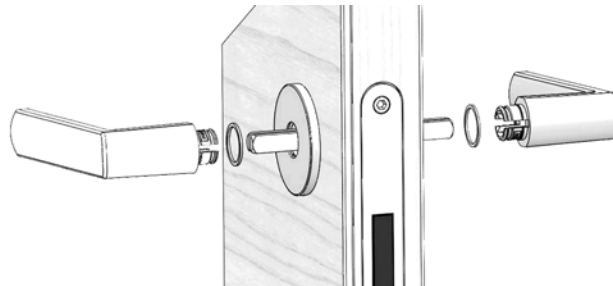

INSERIRE LE IMPUGNATURE (5/6) SUL FERRO QUADRO (1), FISSARE LA PRIMA IMPUGNATURA CON LA VITE GRANO (7), FISSARE LA SECONDA IMPUGNATURA CON LA VITE GRANO (7) CON LA CHIAVE (8) TENENDO ENTRAMBE LE IMPUGNATURE BENE IN APPOGGIO SULLE ROSETTE.

SLIDE BOTH LEVER HANDLES (5/6) ON THE SQUARE SPINDLE (1), FIX THE LEVER HANDLES BY KEEPING THEM FIRMLY AGAINST THE ROSES WHILE TIGHTENING THE GRUB SCREW (7) WITH THE ALLEN KEY (8).

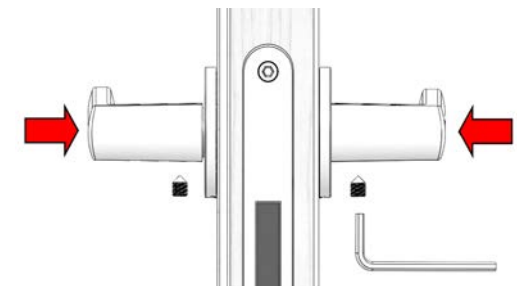

**ISTRUZIONE MONTAGGIO NOTTOLINO WC CON ROSETTA 52x10 TONDA E QUADRA (MONTAGGIO CON VITI LEGNO).
INSTALLATION SCHEME TURN & RELEASE ON 52x10 ROUND AND SQUARE ROSE (WOOD SCREWS)**

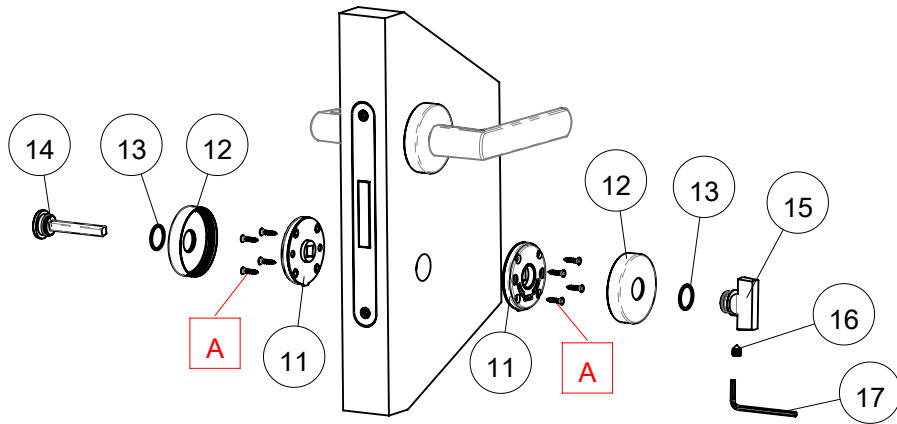

11	SOTTO ROSETTA SENZA MOLLA PER WC	INNER ROSE WITHOUT SPRING FOR TURN & RELEASE
12	ROSETTA	ROSE COVER
13	RONDELLA IN NYLON	NYLON WASHER
14	NOTTOLINO EMERGENZA ESTERNO	EMERGENCY RELEASE
15	NOTTOLINO GIREVOLE INTERNO	PRIVACY SNIB TURN
16	VITE GRANO PER FISSAGGIO NOTTOLINO INTERNO GIREVOLE	GRUB SCREW TO FIX THE PRIVACY SNIB TURN
17	CHIAVE ESAGONALE PER VITE GRANO	ALLEN KEY
A	VITI FISSAGGIO SOTTOROSETTE	SCREW FIXINGS

SC. 03

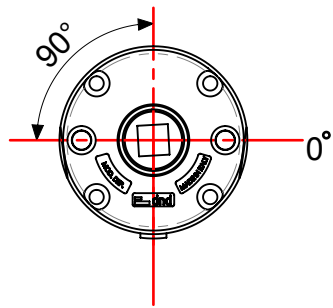

POSIZIONARE LE SOTTO ROSETTE (11) SULLA PORTA INSERIRE IL NOTTOLINO DI EMERGENZA ESTERNO (14) ED IL NOTTOLINO GIREVOLE INTERNO (15), IN MODO CHE LE SOTTO ROSETTE SIANO CENTRATE CON IL QUADRO DELLA SERRATURA.

PLACE THE INNER ROSES (11) ON THE DOOR, INSERT THE EMERGENCY RELEASE (14) AND THE PRIVACY SNIB TURN (15) PAYING ATTENTION THAT THE INNER ROSES ARE CENTERED WITH THE SQUARE HOLE IN THE LOCK.

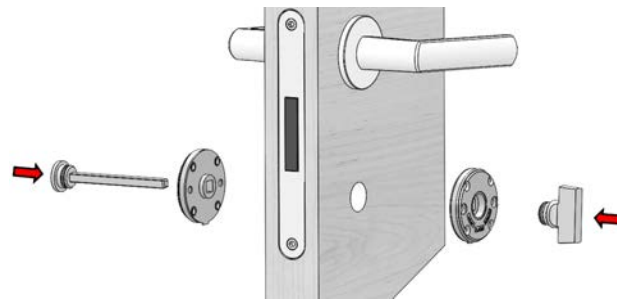

FISSARE LE SOTTO ROSETTE (11) CON LE VITI (A) FORNITE RISPETTANDO LO SCHEMA "SC.3" E LA POSIZIONE INFERIORE DELLA TACCA .

FIX THE INNER ROSES (11) BY USING THE PROVIDED SCREW FIXINGS (A) FOLLOWING THE DIAGRAM "SC.03" AND THE LOWER POSITION OF THE INNER ROSE NOTCH.

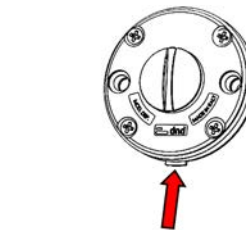

TACCA INFERIORE
NOTCH FACING DOWN

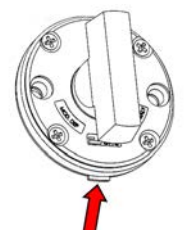

TACCA INFERIORE
NOTCH FACING DOWN

ESTRARRE IL NOTTOLINO GIREVOLE INTERNO (15) ED IL NOTTOLINO EMERGENZA ESTERNO (14).

REMOVE THE PRIVACY SNIB TURN (15) AND THE EMERGENCY RELEASE (14).

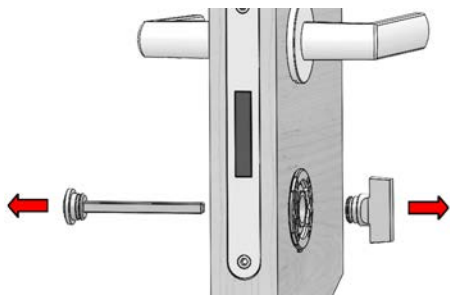

APPLICARE SULLE SOTTO ROSETTE (11) LE ROSETTE (12) RISPETTANDO LA POSIZIONE DELLA TACCA INFERIORE.

APPLY THE ROSE COVERS (12) ON THE INNER ROSES (11) PAYING ATTENTION TO THE LOWER POSITION OF THE NOTCH.



TACCA INFERIORE
NOTCH FACING DOWN

INSERIRE LE RONDELLE IN NYLON (13) SUL NOTTOLINO EMERGENZA (14) E NOTTOLINO GIREVOLE (15) INSERIRLI NEL FORO DELLE ROSETTE(12).

SLIDE THE NYLON WASHERS ON THE EMERGENCY RELEASE (14) AND PRIVACY SNIB TURN (15), INSERT THEN BOTH (14 & 15) IN THE ROSES HOLE (12).

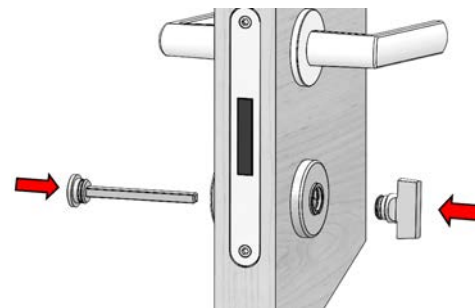

TENERE IN APPOGGIO SULLE ROSETTE IL NOTTOLINO DI EMERGENZA (14) ED IL NOTTOLINO GIREVOLE (15) E FISSARE CON LA VITE GRANO (16) UTILIZZANDO LA CHIAVE (17).

KEEP FIRMLY BOTH THE EMERGENCY RELEASE (14) AND PRIVACY SNIB TURN (15) AGAINST THE ROSES WHILE TIGHTENING THE GRUB SCREW (16) WITH THE ALLEN KEY (17).

