

DUNAVOX

THE WINE COOLING EXPERT

DUNAVOX Grande

EN USER MANUAL



PREFACE

Dear customer,

Thank you for buying this appliance and putting your trust in Dunavox. We have designed this product with the greatest care, and hope it will be proud and long-term addition to your house. If you have any questions about your appliance, please let us know; we are happy to help you!

TABLE OF CONTENTS

1. About this document	4	6. Use	16
1.1. Language	4	6.1. Displays	16
1.2. Relevant documentation	4	6.2. Operating the appliance	18
1.3. Used symbols	4	6.3. Modes	20
2. Product description	5	6.4. Display settings	23
2.1. Conformity	5	6.5. Energy saving	24
3. Safety	5	7. Maintenance	24
3.1. Intended use	5	7.1. Quick cleaning	25
3.2. Intended users	6	7.2. Thorough cleaning	25
3.3. Safety instructions	6	7.3. Defrosting the appliance	26
4. Transport and storage	8	7.4. Replacing the filter	26
4.1. Transport	8	7.5. Filling the humidity box	26
4.2. Storage	8	8. Troubleshooting	27
5. Installation	8	8.1. Alarms	30
5.1. Choosing a location	9	9. Disposal	31
5.2. Installing the appliance freestanding (optional)	10	10. Warranty	31
5.3. Installing the ventilation grille	11		
5.4. Preparing the appliance for installation	11		
5.5. Connecting the power supply	13		
5.6. Placing the appliance	13		
5.7. Installing the handle	14		
5.8. Reversing the door direction	14		
5.9. Finishing the installation	15		

1. ABOUT THIS DOCUMENT

This manual is applicable to all Grande models from Dunavox. If chapters are only applicable to some models, this will be mentioned in the title or at the beginning of the chapter.

Read and understand this manual before using the product. Carefully store this manual for future reference.

We reserve the right to change the parameters without prior notice.

1.1. Language

This manual is originally written in English. All other languages are translations of the original manual.



1.2. Relevant documentation

The following documentation is available for this appliance:

Document	Location
User manual	This document
Energy label	Packed in the appliance
Installation drawing	

1.3. Used symbols

This manual contains safety instructions. Ignoring these instructions may lead to injury or damage to the appliance. Each safety instruction is indicated with a signal word. The signal word corresponds with the level of risk of the described hazardous situation.

 WARNING	This symbol indicates a hazardous situation which, if not avoided, <u>could</u> result in death or serious injury.
 CAUTION	This symbol indicates a hazardous situation which, if not avoided, <u>could</u> result in minor or moderate injury.
NOTICE	This symbol indicates a situation which, if not avoided, <u>could</u> result in damage to the product.

Other symbols in this manual do not refer to safety.

 Tip!	This symbol indicates a tip that is useful for some users.
---	--

2. PRODUCT DESCRIPTION

This appliance is a high quality wine cooler with a premium look and feel. The appliance is equipped with a dynamic climate mode which is ideal for storing wine bottles for a long period of time.

The following table shows the number of zones and the bottle capacity per model.

	Grande							
	58	70	94	123	143	166	181	194
Number of zones	2	1	2	2	1	2	2	1
Bottle capacity	58	70	94	123	143	164	181	183

See appendix 1 for the complete list of specifications.

2.1. Conformity

This appliance is designed and tested according to the following regulations and directives:

LV 2015/35/EU
EMC 2014/30/EU
ERP 2009/125/EC
RoHS 2011/65/EC
CB

3. SAFETY

3.1. Intended use

This appliance is intended for storing wines at their optimal temperature.

This appliance can be used freestanding or built into a column.

The appliance is intended for use in household and commercial environments.

The appliance is for indoor use only.

This appliance is intended to be used for the storage of wine.

3.2. Intended users

This appliance can be used by children aged from 8 years and above and persons with reduced physical, sensory or mental capabilities or lack of experience and knowledge if they have been given supervision or instruction concerning use of the product in a safe way and understand the hazards involved. Children shall not play with the product. Cleaning and user maintenance shall not be done by children without supervision.

3.3. Safety instructions

⚠ WARNING

Risk of electric shock. When the appliance is connected to the mains it contains a high voltage:

- Switch off the fuse of the power outlet before connecting the appliance to the mains.
- Earth the appliance.
- Switch off the fuse of the power outlet before performing maintenance.
- Do not move the appliance when the appliance is connected to an active power outlet.
- Do not connect the appliance to a power outlet when the power cord is damaged. If the power cord is damaged, it must be replaced by the manufacturer, or an authorized service centre.
- Do not connect the appliance to a faulty power outlet.
- Keep the appliance and the power cord away from water or moisture.
- Do not unplug the appliance by pulling on the cable. Always grasp the connector and pull.
- Do not unplug the appliance with wet hands.
- Do not locate multiple power outlets or extension cords behind the appliance.

⚠ WARNING

Refrigerant is highly flammable! Refrigerant can cause fire when in contact with flames or sparks.

- Do not operate the appliance in the presence of explosive or flammable fumes.
- Do not operate the appliance when the refrigerant circuit is damaged.
- If refrigerant has leaked out of the appliance:
 - Avoid any fire or sparks.
 - Switch off the fuse of the power outlet of the appliance.
 - Air the room in which the appliance is located for several minutes.
 - Contact Dunavox for advice.
- Do not use mechanical devices to accelerate the defrosting process.

⚠ WARNING

Risk of suffocation! Children playing with the packaging material can lead to injury. Keep the packaging out of reach of children.

▲ CAUTION

The appliance is heavy. Carrying and moving the appliance on your own can cause injury. Always lift and move the appliance with two people.

▲ CAUTION

The appliance is not built to be repaired by the user. Attempts to repair the appliance can lead to injury and damage to the appliance, and voids the warranty:

- Do not repair or replace any part of the appliance unless it is specifically recommended in this manual.
- Do not use accessories not recommended by the manufacturer.
- Do not use other electrical appliances inside the appliance.

NOTICE

External heat sources can influence the performance of the appliance:

- Do not install the appliance in direct sunlight.
- Do not install the appliance next to heat sources such as ovens, stoves, heaters, and radiators.

NOTICE

The ventilation cannot work properly when the ventilation grids are covered. The appliance can overheat. Do not cover the ventilation grids.

NOTICE

Storing opened bottles in the appliance can cause leakage and mold in the appliance. Do not store bottles that have been opened.

NOTICE

Multiple wine bottles can be heavy and can influence the centre of gravity of the appliance and cause the appliance to tilt:

- Pay attention to the placement of bottles in the appliance:
 - Do not slide out more than one loaded rack at once.
 - If a rack is loaded with more than one layer of bottles, do not slide out the rack.
 - Try to distribute the bottles evenly throughout the appliance.

4. TRANSPORT AND STORAGE

The transport and storage must comply with the following climate condition:

Ambient temperature	1 - 40 °C
Ambient humidity	< 95% (not condensing)

4.1. Transport

Keep the following things in mind when transporting the appliance:

- Transport the appliance in the original packaging.
- Transport the appliance with two people.
- Do not tilt the packaging more than 45°.

If the appliance is already unpacked, make sure to:

- Lock the door in closed position with tape.
- Protect the outside of the appliance. Use a soft, thick cloth.

4.2. Storage

Store the appliance in the original packaging.

5. INSTALLATION

The installation process of the appliance consists of the following steps:

Built into a column	Freestanding
Choosing a location	Choosing a location
Installing the ventilation grille	Installing the appliance freestanding
Preparing the appliance for installation	
Connecting the power supply	
Placing the appliance	
Installing the handle	
Reversing the door direction	
Finishing the installation	

The following chapters give more explanation about each step.

5.1. Choosing a location

NOTICE

External heat sources can influence the performance of the appliance:

- Do not install the appliance in direct sunlight.
- Do not install the appliance next to heat sources such as ovens, stoves, heaters, and radiators.

The installation room must meet the following conditions:

Operating temperature	16 - 38 °C
Operating humidity	< 95% (not condensing)
Air volume	> 1 m ³ per 8 g of coolant

Keep in mind that installation in open plan kitchens or against partition walls can increase the noise pollution emitted by the appliance.

The appliance can be built into a column or can be used as a freestanding appliance. The installation location must meet the following conditions:

- Not directly next to or above an oven.
- Bottom surface strong enough to support the loaded appliance (see appendix 1).
- Dry, stable, and flat surface.
- Close to a separated power outlet (220 - 240 VAC; 50 Hz).

When built into a column, the appliance may only be installed into kitchen furniture. The cabinet must meet the following conditions:

- Power outlet located at the back side of the cabinet.
- Minimal space as shown on the installation drawing (delivered with the appliance).

Tip! You can also find the installation drawing on www.dunavox.com.

If you want to use the appliance freestanding, go to chapter 5.2. If you want to build the appliance into a column, go to chapter 5.3.

5.2. Installing the appliance freestanding (optional)

To install the appliance freestanding, do the following:

1. Remove all exterior and interior packaging.

Tip! The product is heavy and can be hard to move over greater distances. We recommend to unpack the product on the installation location.

2. Check if all contents in the packaging are present and undamaged. The table shows which contents should be present in the packaging.

	Grande							
	58	70	94	123	143	166	181	194
Dunavox wine cooler	1×	1×	1×	1×	1×	1×	1×	1×
User manual	1×	1×	1×	1×	1×	1×	1×	1×
Door handle (only for stainless steel version)	1×	1×	-	1×	1×	-	1×	1×
Door handle screws (only for stainless steel version)	2×	2×	-	2×	2×	-	2×	2×
Allen key (only for stainless steel version)	-	-	-	1×	-	-	-	-

If parts are missing or damaged, contact your supplier.

Tip! If the power cable and power outlet are not accessible after installation, connect the power supply before performing the next step. Make sure to switch off the fuse of the power outlet when you are moving the appliance.

3. Install the door handle (chapter 5.7, not necessary for Grande 166).
4. If desired, reverse the door direction (chapter 5.8).
5. Adjust the legs until the appliance stands on all 4 feet and is level and stable.
6. Slide the appliance into the preferred end position. Make sure that:
 - The power cable is not trapped under the appliance.
 - The power cable is still accessible.
 - There is 10 cm free space at the back of the appliance.

7. Check again if the appliance is level and stable. If not, adjust the legs until the appliance stands on all 4 feet and is level and stable.

Tip! If the free space at the top of the appliance is less than 5 mm, lower the appliance by screwing in the installation legs. Make sure to level and stabilise the appliance afterwards.

8. Use warm water and a soft cloth to clean the interior of the appliance.

Tip! The inside of the appliance may have residual odours at first. The odours disappear when the appliance is operating.

9. Let the appliance stand upright for at least 24 hours. During this time you can keep the door of the appliance open to let residual odours escape.
10. Switch off the fuse of the power outlet.
11. Plug the power cable into the power outlet. Make sure to earth the appliance.
12. Switch the fuse of the power outlet back on.
13. Check if the appliance switches on.

The appliance is now ready for use. Go to chapter 6.

5.3. Installing the ventilation grille

The ventilation grille of the appliance is located at the bottom of the appliance, below the door. If you want to cover the space below the door with a plinth:

1. Remove the original grille from the appliance.
2. Install a plinth with a ventilation grille in front of the appliance. Make sure the grid of the ventilation grille is at least the same size as the original grille.

5.4. Preparing the appliance for installation

Prepare the installation of the appliance as followed:

1. Remove all exterior and interior packaging. Do not remove the installation legs yet.

Tip! The product is heavy and can be hard to move over greater distances. We recommend to unpack the product on the installation location.

- Check if all contents in the packaging are present and undamaged. The table shows which contents should be present in the packaging.

	Grande							
	58	70	94	123	143	166	181	194
Dunavox wine cooler	1×	1×	1×	1×	1×	1×	1×	1×
User manual	1×	1×	1×	1×	1×	1×	1×	1×
Door handle (only for stainless steel version)	1×	1×	-	1×	1×	-	1×	1×
Door handle screws (only for stainless steel version)	2×	2×	-	2×	2×	-	2×	2×
Allen key (only for stainless steel version)	-	-	-	1×	-	-	-	-

If parts are missing or damaged, contact your supplier.

- Use warm water and a soft cloth to clean the interior of the appliance.

Tip! The inside of the appliance may have residual odours at first. The odours disappear when the appliance is operating.

- Let the appliance stand upright for at least 24 hours. During this time you can keep the door of the appliance open to let residual odours escape.
- Place the appliance in front of the installation location. Keep 0,5 m space between the appliance and the cabinet for electrical installation.

The appliance is now ready for electrical installation.

5.5. Connecting the power supply

⚠ WARNING

Risk of electric shock. When the appliance is connected to the mains it contains a high voltage:

- The electrical installation must comply with local and national requirements.
- The electrical installation must be done by a qualified and competent person.
- Switch off the fuse of the power outlet before connecting the appliance to the mains.
- Earth the appliance.
- Do not move the appliance when the appliance is connected to an active power outlet.
- Do not connect the appliance to a power outlet when the power cord is damaged. If the power cord is damaged, it must be replaced by the manufacturer, or an authorized service centre.
- Do not connect the appliance to a faulty power outlet.

6. Switch off the fuse of the power outlet to safely continue with the installation.

5.6. Placing the appliance

To place the appliance, do the following:

1. Make sure the electrical installation is finished before the appliance is built in (see chapter 5.5).
2. Adjust the legs until the appliance stands on all 4 feet and is level and stable.
3. Slide the appliance into the cabinet. Make sure:
 - The power cable is not trapped under the appliance.
 - The appliance does not touch the back wall.
 - The appliance stands in the middle of the cabinet.
 - There is at least 5 mm free space at the top of the appliance.
4. Check again if the appliance is level and stable. If not, adjust the legs until the appliance stands on all 4 feet and is level and stable.

5.7. Installing the handle

Only when handle is delivered separately

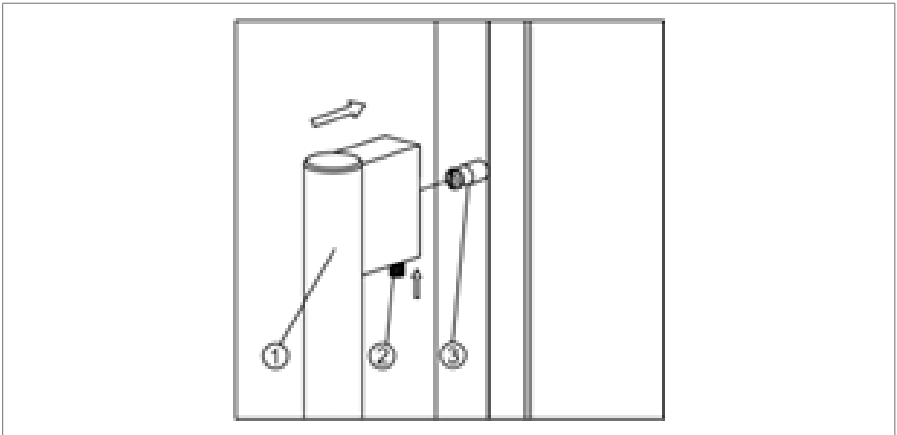

To install the door handle:

1. Place the handle over the pins on the door.
2. Use the supplied Allen key to secure the screws at the inside of the handle.

5.8. Reversing the door direction

Optional

If desired, the door direction can be reversed after the appliance is installed. We recommend reversing the door direction with two people.

▲ CAUTION

Risk of hand injury. The door exerts a lot of force on the hinges. When your hand is in the hinging area of the hinges, keep the door open with your other hand.

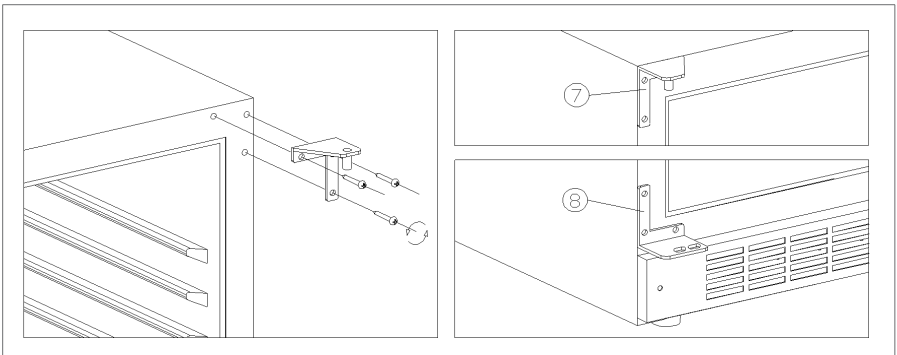

To reverse the door direction, follow the next steps:

1. Prepare a flat and soft surface to place the door on during the process.
2. Unscrew the three screws from the bottom hinge.

▲ WARNING

The door is made of glass and can break when it falls. When reversing the door direction, let another person support the door when unscrewing the hinges.

3. Unscrew the three screws from the top hinge.
4. Place the door on the soft surface.
5. Remove the hole covers.
6. Rotate the door 180°. Align the hinges with the free holes at the top and bottom of the appliance.
7. Secure the top hinge with three screws. Do not tighten the screws yet.
8. Secure the bottom hinge with three screws. Do not tighten the screws yet.
9. Level the door and secure all screws.
10. Place the hole covers.

5.9. Finishing the installation

To finish the installation:

1. Switch on the fuse of the power outlet.
2. Check if the appliance switches on.

You can now use the appliance.

Tip! When using the appliance for the first time we recommend waiting 2 to 3 hours before placing the bottles into the appliance to allow the appliance to reach the set temperature.

6. USE

6.1. Displays

The following table shows which display is applicable to your model.

		Grande							
			70	94	123	143	166	181	194
Single zone		-	✓	-	-	✓	-	-	✓
Dual zone	Type 1	✓	-	✓	-	-	✓	✓	-
	Type 2	-	-	-	✓	-	-	-	-

6.1.1. Single zone display

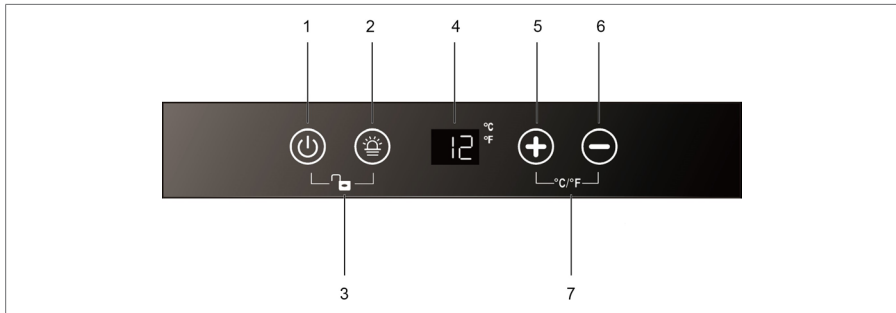

1. Power button
2. Interior light button
3. Lock display
4. Display
5. Temperature up button
6. Temperature down button
7. Celsius/Fahrenheit indicator

6.1.2. Dual zone type 1 display

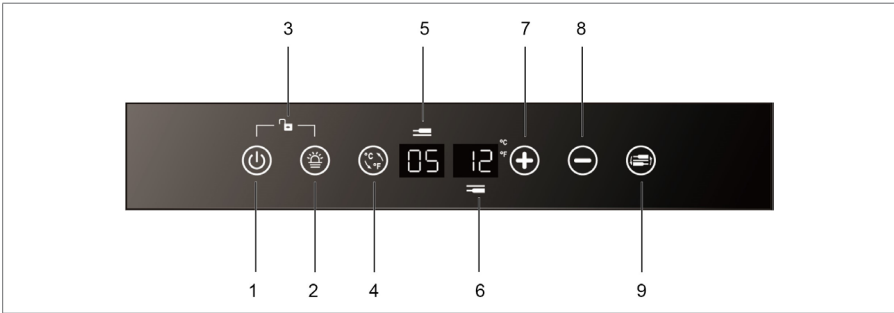

- | | |
|---------------------------------|----------------------------|
| 1. Power button | 6. Display (lower zone) |
| 2. Interior light button | 7. Temperature up button |
| 3. Lock display | 8. Temperature down button |
| 4. Celsius/Fahrenheit indicator | 9. Dynamic climate mode |
| 5. Display (upper zone) | |

6.1.3. Dual zone type 2 display

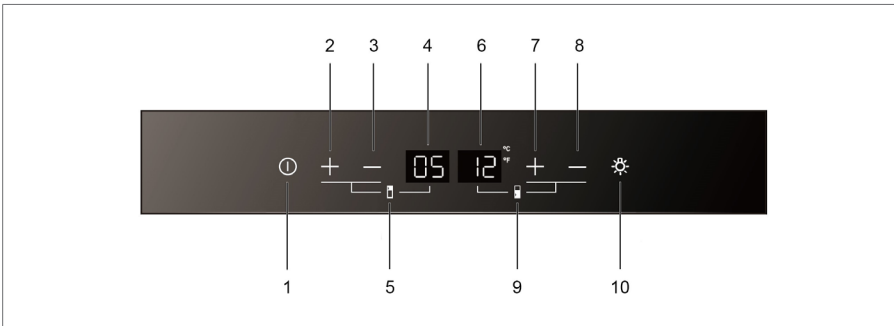

- | | |
|---|---|
| 1. Power button | 6. Lower zone icon |
| 2. Temperature up button (upper zone) | 7. Display (lower zone) |
| 3. Temperature down button (upper zone) | 8. Temperature up button (lower zone) |
| 4. Display (upper zone) | 9. Temperature down button (lower zone) |
| 5. Upper zone icon | 10. Interior light button |

6.2. Operating the appliance

6.2.1. Switching the appliance on or off

The appliance switches on automatically when the power outlet is switched on. To switch off the appliance:

- Press and hold the **power button** for 5 seconds.

NOTICE

Risk of damage to your appliance. Do not switch on the appliance directly after it switched off. Wait 5 minutes before restarting the appliance.

To switch on the appliance:

- Press and hold the **power button** until the display lights up.

6.2.2. Controlling the temperature

The optimal temperature depends on the wine type:

Wine type	Optimal temperature	
Red wine	10 – 20 °C	58 – 68 °F
White wine	5 – 10 °C	41 – 50 °F
Maturing wine	11 – 14 °C	52 – 57 °F

Always check the bottle label for the optimal storage temperature of your wines.

Zones

The appliance can be equipped with multiple zones. Each zone is suitable for different kinds of wines. The displays show the current temperature in the corresponding zones.

Tip! If you want to switch the units on the display between °C and °F (see chapter 6.4.).

Type	Zone	Wine types	Temperature settings	
Single zone		All wine types	Depending on wine type	
Double zone	Upper zone	Champagne; white wine	5 – 12 °C	41 – 54 °F
	Lower zone	White wine; red wine	12 – 20 °C	55 – 68 °F

For the Grande-123 model: for optimal performance, we recommend a temperature difference between the zones of at least 4 °C.

Controlling the temperature

To control the temperature settings:

1. Press one of the **temperature buttons** to check the set temperature. The set temperature blinks on the display.
2. Use the **temperature buttons** to change the temperature.

When the temperature buttons are not touched for more than 5 seconds, the display stops blinking and shows the current temperature in the corresponding zone again.

NOTICE

If the temperature on the display keeps blinking, the measured temperature deviates more than 5 °C from the set temperature. A temperature deviation of more than 5 °C could impair a wine. Check if the stored wines can handle the difference in temperature, and if not, remove the wine from the cooler until the display stops blinking.

The temperature memory function makes sure the temperature settings remain the same when the appliance switches on after a power loss.

6.2.3. Storing wine

The amount of wine that can be stored in the appliance depends on the size of the bottles. The capacity mentioned in chapter 2 is an approximated maximum based on Bordeaux 750 ml bottles.

NOTICE

Multiple wine bottles can be heavy and can influence the centre of gravity of the appliance and cause the appliance to tilt. Pay attention to the placement of bottles in the appliance:

- Do not slide out more than one loaded rack at once.
- If a rack is loaded with more than one layer of bottles, do not slide out the rack.
- Try to distribute the bottles evenly throughout the appliance.

NOTICE

Opened bottles can cause spillage in the appliance. Only place unopened bottles in the appliance.

To store wine in your appliance, do the following:

1. Fully open the door.
2. Pull out one of the racks.
3. Place your bottle flat on the rack.
4. Push the rack back into the appliance.
5. Close the door properly.

For optimal performance of the appliance keep the following things in mind:

- If you do not have enough bottles to fill your appliance, distribute the bottles as evenly as possible through the appliance.
- Keep a gap between the wall and the bottles to allow air circulation.

6.2.4. Adding a humidity box (optional)

When the appliance is installed in a very dry climate (humidity below 40%) you can place a humidity box into the appliance.

Tip! Keep in mind that using the humidity box decreases the bottle capacity of the appliance.

To add the humidity box, do the following:

1. Fill the humidity box with water.
2. Place the humidity box on the shelf with runners.

6.3. Modes

The different models can have different modes and controls. The following table shows which chapters are applicable to your model.

	Grande							
	58	70	94	123	143	166	181	194
Interior light mode	√	√	√	√	√	√	√	√
Dynamic climate mode	√	√	√	√	√	√	√	√
Eco demo mode	-	-	-	√	-	-	-	-
Sound modes	-	-	-	√	-	-	-	-
Sabbath mode	-	-	-	√	-	-	-	-

6.3.1. Interior light modes

The interior light has two modes:

- In *Functional mode* the interior light only switches on when the door is opened.
- In *Showcase mode* the interior light is always switched on.

To switch between both modes:

- Press the **interior light button**. When the appliance is in *Showcase mode*, a light indicator shows at the bottom right of the display.

Tip! If a LED fitting is not working, contact your supplier.

To adjust the brightness of the interior light:

1. Press and hold the **temperature up button** for 5 seconds to enter settings mode.
2. Press the **power button** twice.
3. Use the **temperature buttons** to change the brightness of the interior light. L3 is the brightest setting.
4. For single zone or dual zone type 2 appliances, press the power button to confirm the selection.
5. Press and hold the **temperature up button** for 5 seconds to exit settings mode.

With the Grande 123, you can also change the interior light colour. To adjust the interior light colour, do the following:

- Press the interior light button. The interior light color starts to change over time. Press the interior light button again to set the interior light on the currently displayed color.

6.3.2. Dynamic climate mode

When the appliance is set to dynamic climate mode, the air circulation system keeps running when the set temperature is reached. This creates a continuous climate in the appliance, which imitates the climate of a wine cellar. Switch on the dynamic climate mode if you want to use the appliance for long term storage of wines.

Display: Single zone or dual zone type 2

To use the *Dynamic climate mode*:

1. Press and hold the **temperature up button** for 5 seconds to enter settings mode.
2. Press the **power button** three times.
3. Use the **temperature buttons** to change the fan mode. The following table shows the different fan modes.

Code	Mode	Function
F0	Silent mode	No ventilation, energy saving
F1	Dynamic cooling mode	Half time
F2	Dynamic cooling mode	Full time

4. For single zone or dual zone type 2 appliances, press the power button to confirm the selection.
5. Press and hold the **temperature up button** for 5 seconds to exit settings mode

Display: dual zone type 1

To use the *Dynamic climate mode*:

1. Press the **Dynamic climate mode button** to switch on *Dynamic climate mode*. The appliance beeps 5 times to indicate that *Dynamic climate mode* is switched on.
2. Press the **Dynamic climate mode button** to switch off *Dynamic climate mode*. The appliance beeps 3 times to indicate that *Dynamic climate mode* is switched off.

6.3.3. Eco demo mode

Only Grande 123

When the appliance is set to *Eco demo mode*, all cooling functions are switched off. Switch on Eco demo mode when you need to show the appliance but don't need the function (e.g. at exhibitions or in salesrooms).

To use *Eco demo mode*:

1. At the controls of the lower zone, press and hold the **interior light button** and both **temperature buttons** for 5 seconds to switch on *Eco demo mode*. The indicator light flashes five times to indicate that *Eco demo mode* is switched on.
2. To switch off *Eco demo mode*, repeat step 1.

6.3.4. Sound modes

Only Grande 123

To set a sound mode:

1. Press and hold the **temperature up button** for 5 seconds to enter settings mode.
2. Press the **power button** 4 times.
3. Use the **temperature buttons** to change the sound mode. See the table below for the different sound modes:

Code	Sensor tone	Alarm tone
S0	On	Off
S1	On	On
S2	Off	Off
S3	Off	On

Tip! Some alarms require direct action. We recommend keeping the alarm tone switched on.

4. For single zone or dual zone type 2 appliances, press the power button to confirm the selection.
5. Press and hold the **temperature up button** for 5 seconds to exit settings mode.

6.3.5. Sabbath mode

Only Grande 123

When the appliance is set to *Sabbath mode*, all displays, lights and audible alarms are switched off.

To use *Sabbath mode*:

1. Press and hold the **power button** and the **interior light button** simultaneously for 5 seconds to switch on *Sabbath mode*. The display and interior lights switch off to indicate that *Sabbath mode* is switched on.
2. To switch off *Sabbath mode*, repeat step 1. The display lights up again.

Sabbath mode switches off automatically after 48 hours.

6.4. Display settings

For dual zone appliances, use the temperature buttons of the lower zone.

Changing the temperature units

To change the temperature units between Celsius and Fahrenheit:

1. Press and hold the **temperature up button** for 5 seconds to enter settings mode.
2. Use the **temperature buttons** to change the unit.
3. For single zone or dual zone type 2 appliances, press the power button to confirm the selection.
4. Press and hold the **temperature up button** for 5 seconds to exit settings mode.

Changing the brightness

To change the brightness of the display:

1. Press and hold the **temperature up button** for 5 seconds to enter settings mode.
2. Press the **power button** once.
3. Use the **temperature buttons** to change the brightness of the display. D3 is the brightest setting.
4. For single zone or dual zone type 2 appliances, press the power button to confirm the selection.
5. Press and hold the **temperature up button** for 5 seconds to exit settings mode.

6.5. Energy saving

The appliance is energy efficient by itself. If you want to use the appliance as efficient as possible:

- Keep the door closed as much as possible.
- Do not change the set temperature too often.
- When you are not using the appliance for long term storage of wine, switch off the *Dynamic climate mode* (see chapter 6.3.2).
- Switch off the appliance when it is empty for a longer period of time.

7. MAINTENANCE

WARNING

Risk of electric shock. When the appliance is connected to the mains it contains a high voltage. Switch off the fuse of the power outlet before performing maintenance.

The following maintenance tasks are needed to keep the appliance in optimal condition:

Maintenance task	Frequency	Information
Quick cleaning	Every month	Chapter 7.1
Replacing the air filter	Every year	Chapter 7.4
Thorough cleaning	When dirty or when not in use for longer periods of time	Chapter 7.2
Defrosting	Every six months (or when the frost on the evaporator is 5 mm thick)	Chapter 7.3
Replacing the filter		Chapter 7.4
Filling the humidity box		Chapter 7.5

The following chapters give instructions on how to perform these maintenance tasks.

7.1. Quick cleaning

NOTICE

Using unsuitable cleaning agents can damage the surfaces of the appliance.

- Do not use any abrasive or aggressive cleaning agents.
- Do not use any abrasive sponges or cloths.
- Clean in the direction of the grain.

NOTICE

The display contains electrical components. Using too much water during cleaning can damage the display. Make sure to wring your cloth or sponge before cleaning the display.

To quickly clean the appliance, do the following:

1. Clean the interior with a damp and soft cloth or sponge.
2. Clean the air vents with a damp and soft cloth.
3. If present, clean the humidity box under running water.
4. Clean the door with glass cleaner and a soft cloth.

7.2. Thorough cleaning

NOTICE

Using unsuitable cleaning agents can damage the surfaces of the appliance.

- Do not use any abrasive or aggressive cleaning agents.
- Do not use any abrasive sponges or cloths.
- Clean in the direction of the grain.

NOTICE

The display contains electrical components. Using too much water during cleaning can damage the display. Make sure to wring your cloth or sponge before cleaning the display.

To thoroughly clean the appliance, do the following:

1. Switch off the fuse of the power outlet.
2. Remove the bottles from the appliance.
3. Remove the shelves from the appliance:
 - a. Slide out the shelf until the recess in the shelf aligns with the plastic rail lock.
 - b. Lift up the shelf to unlock it from the rails.
4. Wash the interior of the appliance with a warm water and baking soda solution (4 tablespoons baking soda per litre of water).
5. Wash the shelves with soapy water.
6. If present, remove the humidity box from the appliance.

7. If present, clean the humidity box under running water.
8. Place back the humidity box.
9. Clean the door with glass cleaner and a soft cloth.

7.3. Defrosting the appliance

To defrost the appliance:

1. Switch off the appliance.
2. Remove the bottles from the appliance.
3. Leave the door open to speed up the process.
4. Place towels at the door opening of the appliance to absorb any water.

Defrosting usually takes 2-4 hours. The appliance is defrosted when all the frost from the evaporator is gone.

5. Switch the appliance back on.
6. If present, refill the humidity box (see chapter 7.5).

7.4. Replacing the filter

The filter is located in the back wall of the appliance. To replace the filter, do the following:

1. Remove the shelf in front of the filter.
2. Rotate the filter 90° clockwise.
3. Remove the filter.
4. Place a new filter.

Tip! You can buy new filters at your supplier.

5. Rotate the new filter 90° to lock it in place.
6. Dispose of the old filter with household waste.

7.5. Filling the humidity box

To fill the humidity box:

1. Take the humidity box out of the appliance.
2. Fill the humidity box for $\frac{3}{4}$ with water.
3. Place back the humidity box.

8. TROUBLESHOOTING

Problem	Possible cause	Possible solution
The appliance does not operate. The display is switched off.	The appliance is not connected to a power outlet.	Connect the appliance to a power outlet (see chapter 5.5).
	The appliance is switched off.	Switch on the appliance (see chapter 6.2.1).
	The circuit breaker tripped.	Switch the circuit breaker back on.
	The fuse of the power outlet is blown.	Replace the fuse.
The appliance does not cool enough.	The temperature is set incorrectly.	Set the temperature again (see chapter 6.2.2).
	The door has been opened too often or for a long period of time.	Keep the door closed as much as possible.
	The door is not closed completely.	Close the door properly.
	The door seal is dirty, worn or broken.	Check the door seal and clean or replace when necessary.
	The humidity box is too dirty.	Clean the humidity box (see chapter 7.2).
	The ventilation openings are blocked or dirty.	Unblock and clean the ventilation openings.

Problem	Possible cause	Possible solution
The appliance frequently switches on and off.	The room temperature is too high for the appliance to work.	Check the climate conditions of the installation location (see chapter 5.1). If not compatible, move the appliance to a location with a lower temperature.
	Too many bottles are added to the appliance at once.	See chapter 6.2.3.
	The door has been opened too often or for a long period of time.	Keep the door closed as much as possible.
	The door is not closed completely.	Close the door properly.
	The door seal is dirty, worn or broken.	Check the door seal and clean or replace when necessary.
The interior light does not work.	The appliance is not connected to a power outlet.	Connect the appliance to a power outlet (see chapter 5.5).
	The circuit breaker tripped.	Switch the circuit breaker back on.
	The fuse of the power outlet is blown.	Replace the fuse.
	The light is switched off on the control panel.	Switch the light back on (see chapter 6.3.1).
	The LED system is broken.	Contact your supplier.
The door does not open.	The door is stuck due to wrong installation.	Check the installation with chapter 3. If needed, redo the installation.
The appliance vibrates.	The appliance is not levelled correctly.	Make sure the appliance is level.

Problem	Possible cause	Possible solution
The appliance seems to make too much noise.	When the appliance is working correctly it is not fully silent. The sounds of the compressor and the cooling system are unavoidable.	Sounds emitted during normal operation are gurgling, humming, cracking, popping and fan operation sounds. If you doubt that the noise you hear is normal operation, contact your supplier.
	The installation of the appliance is incorrect.	Check if the appliance is installed following chapter 5.
	The appliance is not levelled correctly.	Make sure the appliance is level.
The door does not close properly.	The appliance is not levelled correctly.	Make sure the appliance is level.
	The door direction is reversed but not correctly installed.	Check if the door is reversed following chapter 5.8.
	The door seal is dirty, worn or broken.	Check the door seal and clean or replace when necessary.
	The shelves are out of position.	Make sure the shelves are slid fully inwards.
Condensation appears on the outside of the glass door.	The appliance is installed in a climate with a high humidity.	This is not a problem for the appliance. If you do not want to see condensation on the outside of the door, install the appliance on a location with a lower humidity.

8.1. Alarms

Alarm on display	Other alarm signals	Cause	Possible solution
E0 – E7	-	Various causes.	Switch off the fuse of the power outlet for 5 minutes to reset the controls. Switch the power back on. If the alarm code is still visible, contact your supplier.
-	The alarm sounds.	The door is open for longer than 60 seconds.	Close the door or press the power button to disable the alarm. The alarm resets when the door is closed.
Display flashes	The alarm sounds.	The display cannot display the correct temperature because it is not in between -9 – 37°C.	Keep the door closed and allow the appliance to cool to the set temperature.
HI	-	Actual temperature in the appliance is higher than the set temperature.	<p>Check if the door sealing is dirty, worn, or broken. If necessary, clean or replace the door sealing.</p> <p>Check if the door is closing properly. If not, see the solution of 'the door does not close properly'.</p> <p>Check if the compressor is working. If not, contact your supplier</p>
HH	-	Display or sensor failure.	Contact your supplier.

9. DISPOSAL



The symbol on the product or its packaging indicates that this product is not to be handled as normal household waste but is to be taken to a recycling collection point for electrical and electronic goods. By correctly disposing of this product you are contributing to the protection of the environment and to the health of your fellow human beings. Improper disposal endangers health and the environment. Further information about the recycling of the product may be obtained from your town hall, refuse collection department or the store where you purchased the product.

If your product is defective, contact Dunavox. We can possibly repair the product or give it a second life. If you have to dispose of the product, dispose the product according to the locally applicable guidelines.

When you sell the product to a new owner, make sure to add this manual or a copy of this manual.

10. WARRANTY

This product comes with a warranty period of 3 years. You can extend the warranty of your compressor up to 5 years if you register your appliance via the following link: dunavox.com/product-registration

The warranty does not cover:

- Damage in transit or when moving the appliance.
- Any damages caused from negligence, accident, improper use, improper installation/service or use for purposes other than those described in the instruction manual.
- Damage caused by connecting your product to the wrong power source.
- Damage from power failure.
- Faulty installation or modification made during installation.
- Damage caused by unauthorized repair.
- Any damages resulting from force majeure, fire disaster or natural disaster.
- Alterations to the product without express permission from the manufacturer.
- Parts such as light, removable shelves, or plastic.
- Any spoilage or damage to wines or any other contents incidental or consequential to possible defects of the unit.

The warranty clauses and specifications are subject to change without notice.

APPENDIX 1: TECHNICAL SPECIFICATIONS

	Grande-58	Grande-70	Grande-94
Dimensions (h × w × d)	1215 × 595 × 680 mm	1215 × 595 × 680 mm	1200 × 595 × 680 mm
Packaging dimensions	1260 × 660 × 745 mm	1260 × 660 × 745 mm	1260 × 660 × 760 mm
Weight (empty)	72 kg	72 kg	72 kg
Max. weight (loaded)	142 kg	156 kg	185 kg
Input power	220 VAC; 50 Hz		
Cooling range	5 – 12 °C / 12 – 20 °C	5 – 20 °C	5 – 12 °C / 12 – 20 °C
Climate class	ST		
Total mass refrigerant	44 g	44 g	49 g

	Grande-123	Grande-143	Grande-166
Dimensions (h × w × d)	1768 × 595 × 575 mm	1835 × 655 × 680 mm	1770 × 595 × 680 mm
Packaging dimensions	1960 × 660 × 630 mm	1970 × 700 × 745 mm	1905 × 660 × 745 mm
Weight (empty)	83 kg	108 kg	100 kg
Max. weight (loaded)	231 kg	280 kg	297 kg
Input power	220 VAC; 50 Hz		
Cooling range	5 – 20 °C / 5 – 20 °C	5 – 20 °C	5 – 12 °C / 12 – 20 °C
Climate class	ST		
Total mass refrigerant	50 g	48 g	51 g

	Grande-181	Grande-194
Dimensions (h × w × d)	1835 × 655 × 680 mm	1835 × 655 × 680 mm
Packaging dimensions	1970 × 700 × 745 mm	1970 × 660 × 745 mm
Weight (empty)	108 kg	108 kg
Max. weight (loaded)	326 kg	328 kg
Input power	220 VAC; 50 Hz	
Cooling range	5 - 12 °C / 12 - 20 °C	5 - 20 °C
Climate class	ST	
Total mass refrigerant	52 g	52 g

Refrigerant specifications

Chemical name	isobutane
Chemical number	R600a

Type plate



The type plate is located in the appliance at the bottom side of the left wall. It contains the following information:

Model number	Product type
Input power	Refrigerant type
Volume	Insulation type
Climate class	Manufacturing country
Dunavox address	

DUNAVOX

THE WINE COOLING EXPERT



www.dunavox.com

English(GB) - Original instructions v2.0 - 06/2023