

AQUAZONE

QUALITY PLUMBING SOLUTIONS

Installation Guide

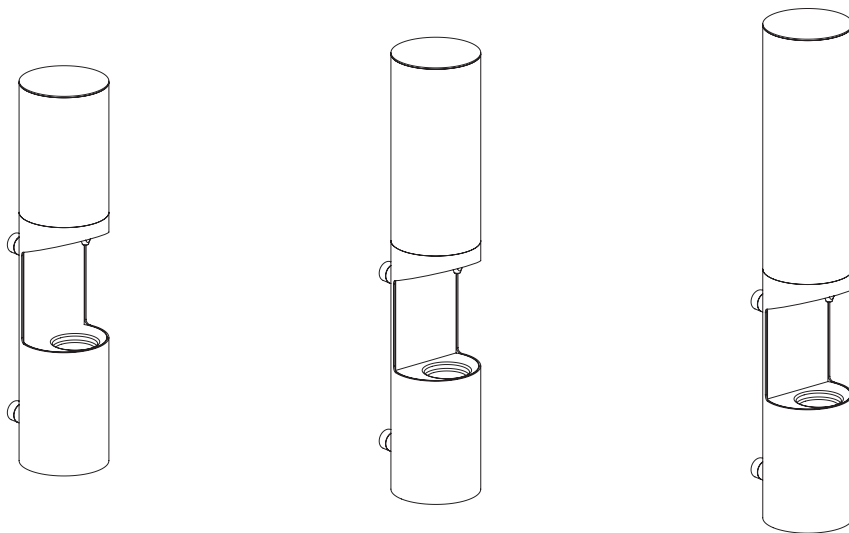

AQA-IX3-755/756-XX

IX304 WALL MOUNTED TOUCHLESS SOAP/SANITIZER DISPENSER BRUSHED STAINLESS STEEL

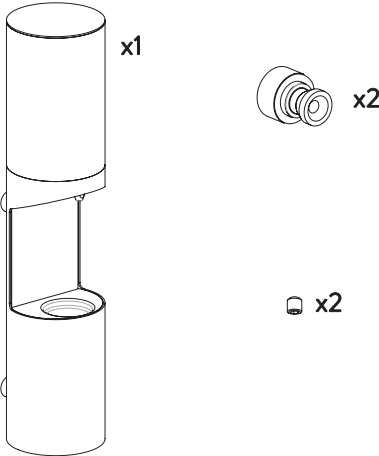
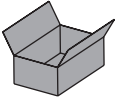

FEATURES

Construction: Brushed AISI304 stainless steel

Activation range: from 1 mm to 100 mm +/- 20 mm.

Sensor response: ~ 0.5 seconds.

Power supply: 4x1.5V AA batteries - **NOT INCLUDED** (Recommended AA/LR6).

Battery holder: IPx5 protection level.

Power supply chain connection: IPx5 protection level.

Pump type: three-lobe rotary peristaltic IP00.

Features: equipotential protection.

Delivery interval: ~ 0.5 ml. . . ~ 1.5 ml.

Default dispensing: minimum dose ~ 0.5 ml.

Suggested products: Germicidal gel, Handwashing solution, Liquid soap, Liquid detergent. (ATTENTION: free of residues / grain / suspensions). Recommended viscosity range: 50mPa · s. . . 15000mPa · s.

Maximum hydraulic circuit loading time: ~ 60 seconds.

Storage temperature: -10 ° C. . . + 60 ° C, relative humidity <80%, no condensation. Operating temperature: -5 ° C. . . + 50 ° C, relative humidity <80%, no condensation.

ASSEMBLING

1

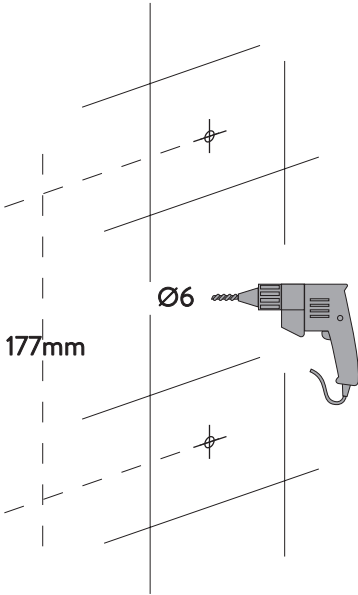

2

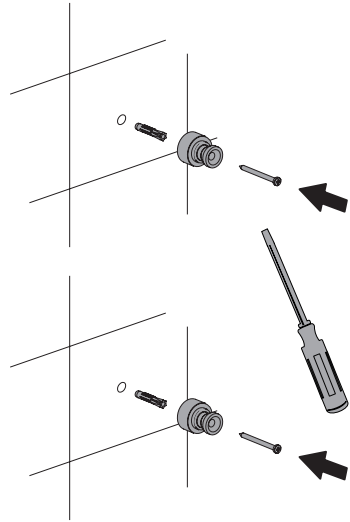

3

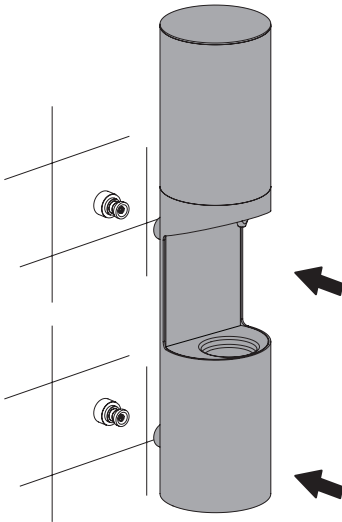

4

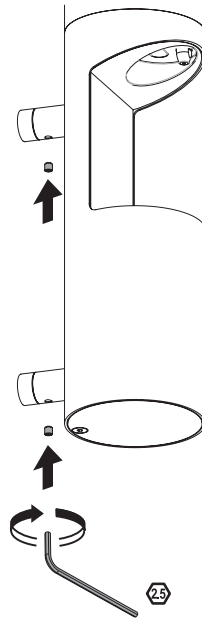

STARTUP (Liquid Filling)

1

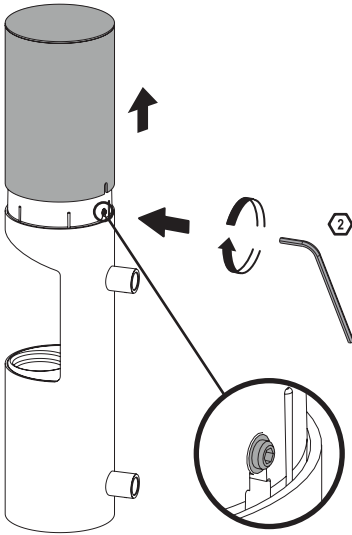

2

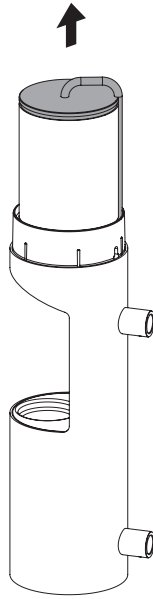

3

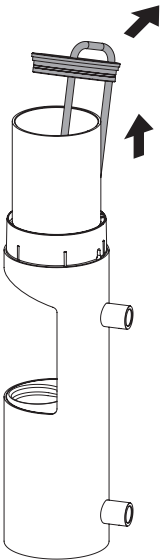

4

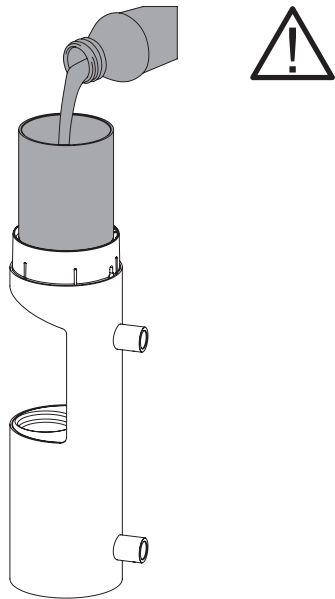

5

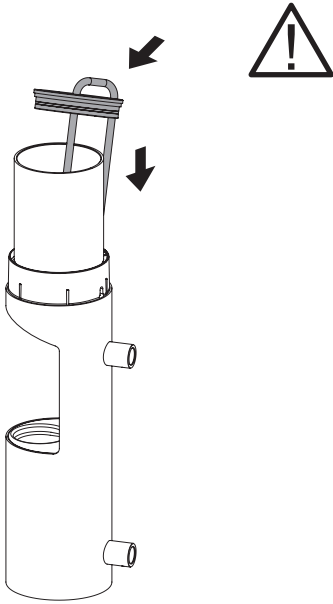

6

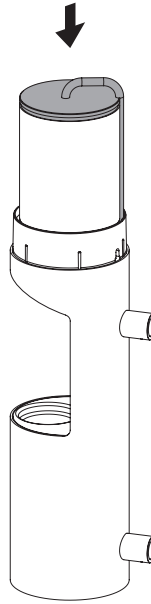

7

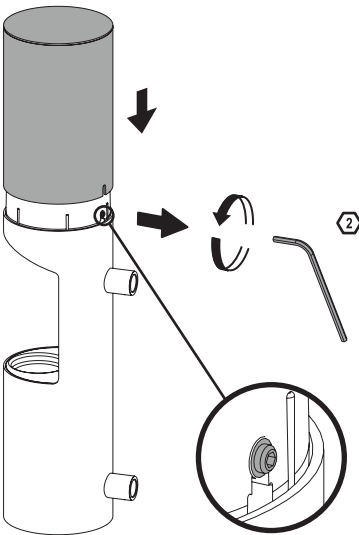

CAUTION!

4 - Fill the tank up to about 2cm from the edge

5 - Do not crush or twist the silicone tube

STARTUP (Battery insertion)

1

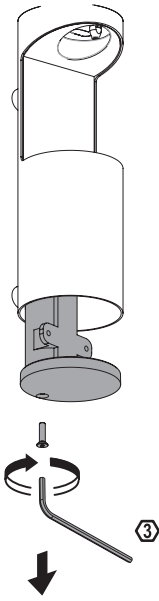

2

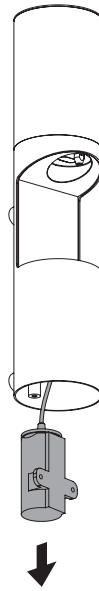

3

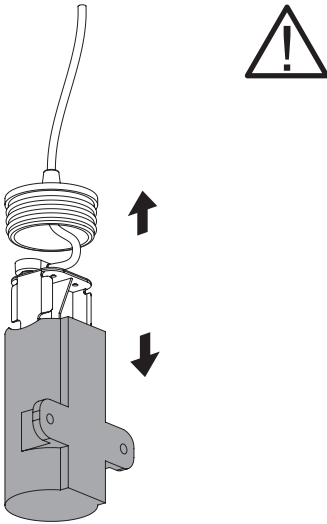

4

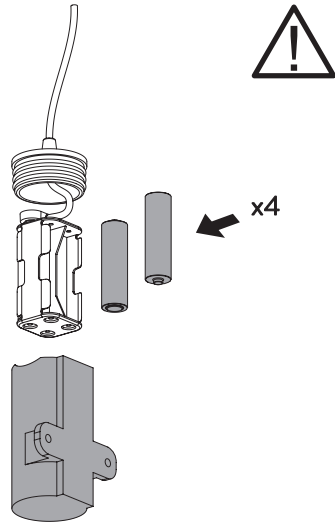

5

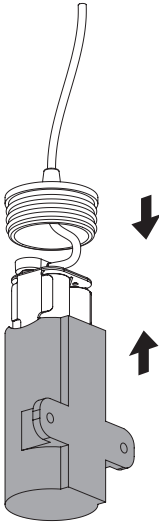

6

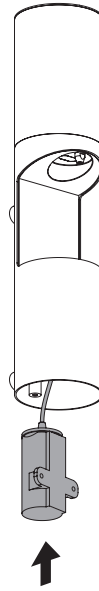

7

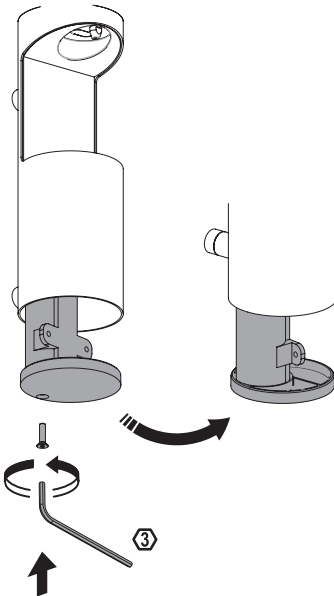
**CAUTION!**

3 - Do not pull or tear the cables of the battery holder

4 - At each battery electrical connection, the RED LED indicator inside the sensor lights up for about 6 seconds, indicating the correct electrical connection of the power supply from the battery pack

INSTRUCTION

AUTOMATIC LOADING:

It is possible to trigger the automatic pump loading system that allows to bring the suction liquid to the level. This function is activated by blinding the sensor continuously only at each battery power connection. The function remains active until the hand blinds the sensor or for a maximum time of about 60 seconds.

The function is deactivated early by removing the blinding.

PRODUCT DELIVERY:

At this point, every time the sensor is blinded, the system will activate to dispense a quantity of product (Gel / Handwash Solution), at the same time the RED indicator light inside the sensor will emit a short flash.

The sensor will wait for a subsequent blinding by the user to start working again.

CHANGE DELIVERY

During normal operation, it is possible to change the delivery duration. To access this functionality, the sensor must be blinded for about 60 seconds.

Continuing with the blinding, the RED indicator light inside the sensor starts flashing a maximum of 6 times. By removing the hand at the desired flash (from 1 to 6) the relative delivery will be set. (Delivery is proportional to the number of flashes. The greater the number of flashes selected, the longer the delivery time)

At this point, the RED indicator light inside the sensor will light up for 3 seconds, following with the same number of flashes chosen for verification. Now you can use the article with the selected setting. If the hand is not removed during the selection process, no signal will be given, much less the previously set delivery value will be changed.

NOTE

SURFACE CLEANING:

Use a damp cloth with a neutral non-abrasive / grainy detergent, rub in the direction of the satin finish, dry the surfaces well.

SENSOR CLEANING:

Use a damp cloth with non-abrasive / grainy neutral detergent, avoiding scratches on the sensor surface, halos and sediments.

PUMP CLEANING:

In the automatic loading condition, suck in at least 0.5 liters of water to leak. It is advisable to empty the hydraulic circuit near the cleaning termination, removing the suction, completely discharge the hydraulic circuit. This operation must be repeated every 6 months, or after / before a programmed period of inactivity of about 2 weeks (depending on the liquid in use and environmental conditions).

BATTERY ASSEMBLY TIPS:

Slide the batteries inside the battery holder, respecting the indicated polarity, to ensure the correct electrical connection between the batteries and the relative battery holder.

