

ECOSCENT

LUNA PRO

IP54

12W

2000m³

CE

RoHS
COMPLIANT



- Wall-mounted or floor standing
- Built in bluetooth function to control
- Custom 24hr working time and fragrance concentration
- Low energy consumption

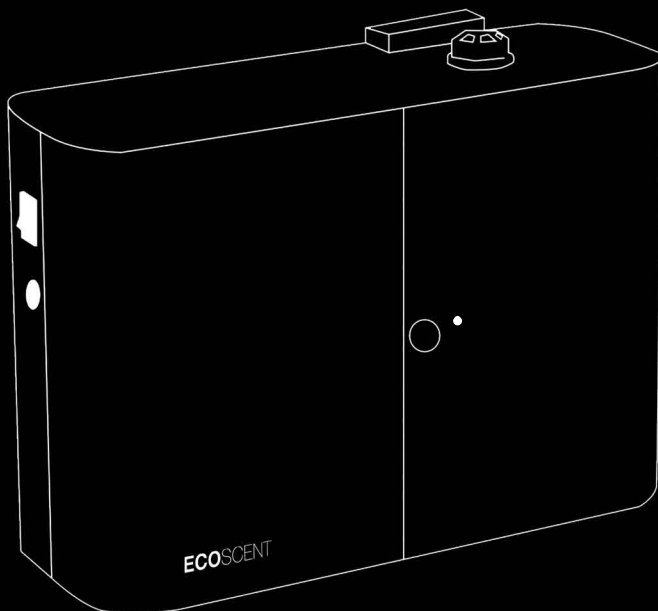

COLOUR OPTIONS



Black



White

SPECIFICATION SHEET

Product Code: : 001-030 White | 001-031 Black

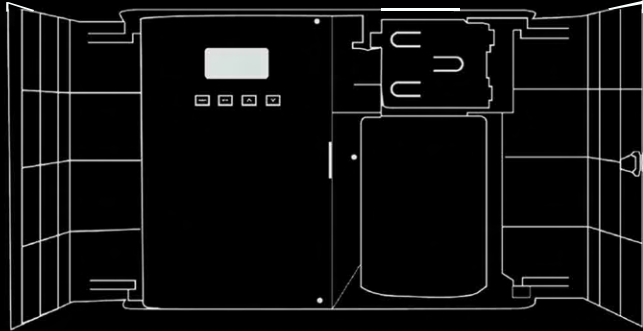

PRODUCT SPECIFICATIONS

Product Name	EcoScent LUNA PRO
Dimensions	W290mm X D110mm X H215mm
Weight	2.2kg
Coverage	2000m ³
HVAC	Available Upon Request
Scent Chamber	750ml
Colour	White or Black
Lifetime	10,000 Hours @ 45°
Operating Temp	0-50°C
IP Rating	IP54
Mounting	Wall-Mounted or Floor Standing
Minimum Noise	<50 Dba
Connection	DC5V - 1A
Control	Programmable Timer / Bluetooth / Program Days & Time / Fragrance Intensity Control
Power Consumption	12W
Supply Voltage	DC 12V
Supply Current	0.41A
Scent Consumption	3ml / Per hour on 100% Concentration. Lasts approx. 50 days (based on 750ml used at 40% concentration, 10 hours a day)
Length of Product Tested	50pc
Input Voltage (V DC)	12V
Input Power (W DC)	2.5W
Total Scent Output (m ³)	2000m ³
Efficiency (SCENT /W)	167



ECOSCENT

Premium Scenting Solutions

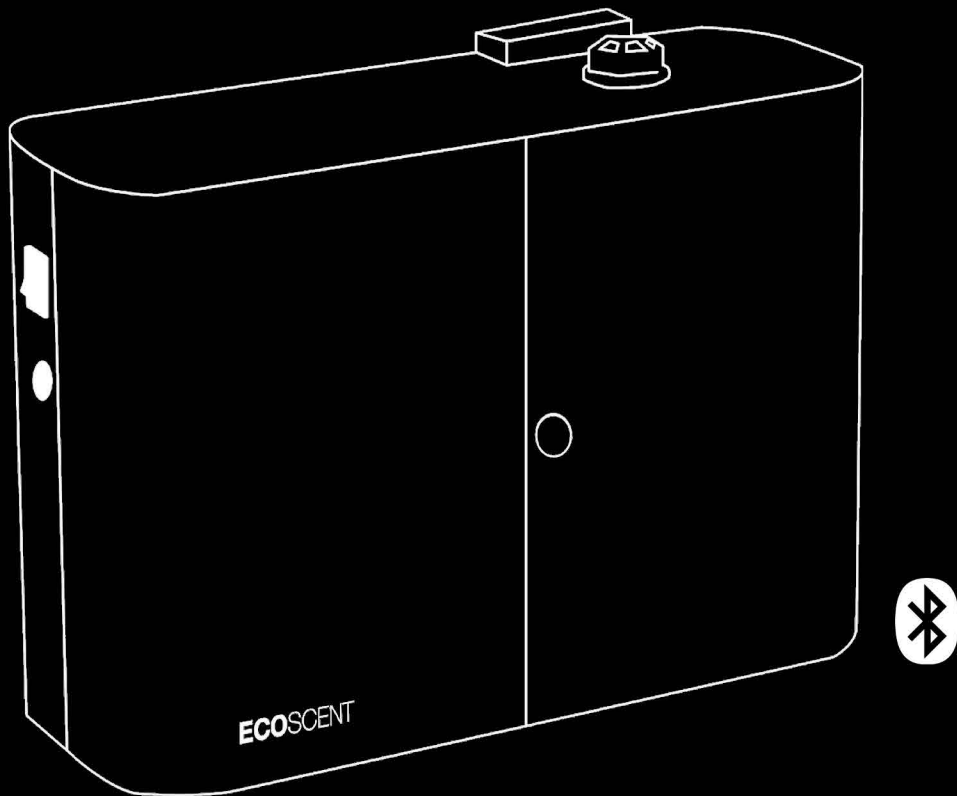

PRODUCT MANUAL LUNA PRO

SAFETY PRECAUTIONS

1. Do not use overloaded power supplies, USB ports, sockets, or use damaged power cords and plugs. If used, it may endanger your safety and may cause fire.
2. Please do not open the inside of the scent delivery system as this may cause damage. If the scent delivery system works in error, please read the user manual carefully, follow the normal procedure or consult after-sales.
3. When the scent delivery system is working, do not disassemble the scent delivery system or shake the scent delivery system vigorously.
4. Do not put the scent delivery system or power adapter in water. Do not put water in the fragrance bottle.
5. When the scent delivery system is already filled with fragrance oil or cleaning solution, do not invert, tilt or rotate the scent delivery system to prevent liquid spillage and damage of the scent delivery system and surfaces.

IN THE BOX



Plug

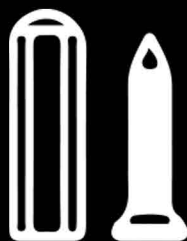

Fixing



Nozzle

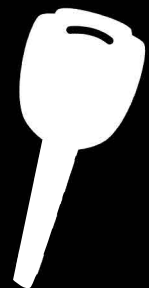

Key

PRODUCT INSTRUCTIONS

The EcoScent LUNA Pro features advanced diffusion technology that converts fragrance oil into a fine, dry, mist, releasing fragrance safely and directly into your environment without sprays or aerosols. Its features: the scent diffusion speed is fast, the atomised particle is fine and smooth, the oil consumption is stable and low.

The EcoScent LUNA Pro uses a professional diaphragm pump which can work for 10,000 hours. The EcoScent LUNA Pro has a touch button panel on the LCD screen to control the working time and aroma concentration based on your preference. This is controlled via the Bluetooth app. Leading technology with patented micron atomisation makes the LUNA Pro's aroma diffuse and spread quickly providing a long lasting fragrance.

MODEL NO.	Luna Pro	DIMENSION	200 x 110 x 215mm
OIL CAPACITY	750 ml	N.W	2.2kg
COVERAGE AREA	2000m ³	VOLTAGE	12V DC
POWER	12W	NOISE	<50dba
OIL CONSUMPTION	3ml per hour on 100%	INSTALLATION METHOD	HVAC Free Standing

INSTALLATION INSTRUCTIONS

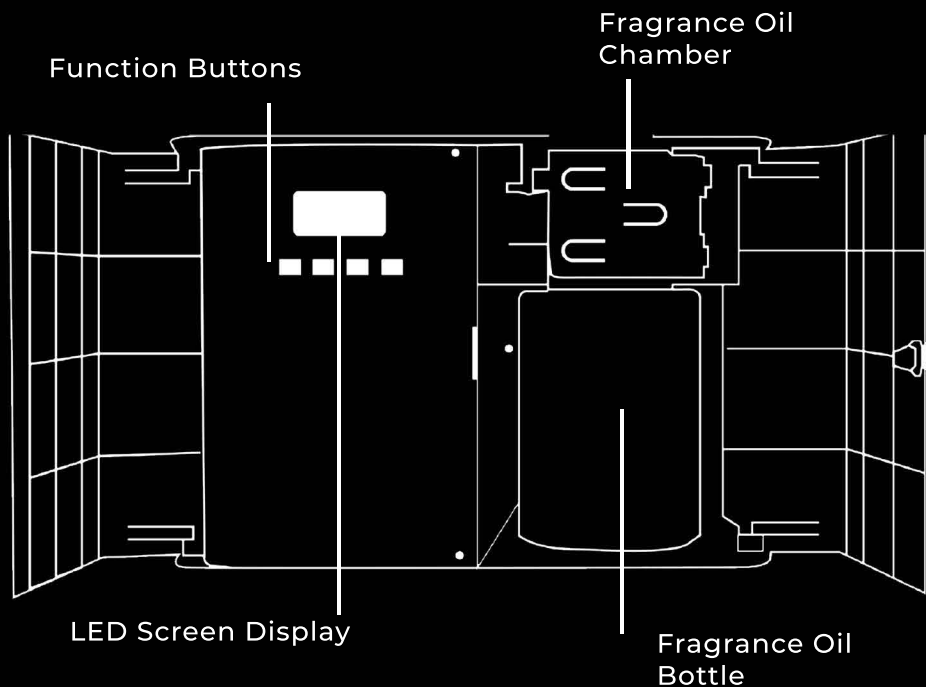
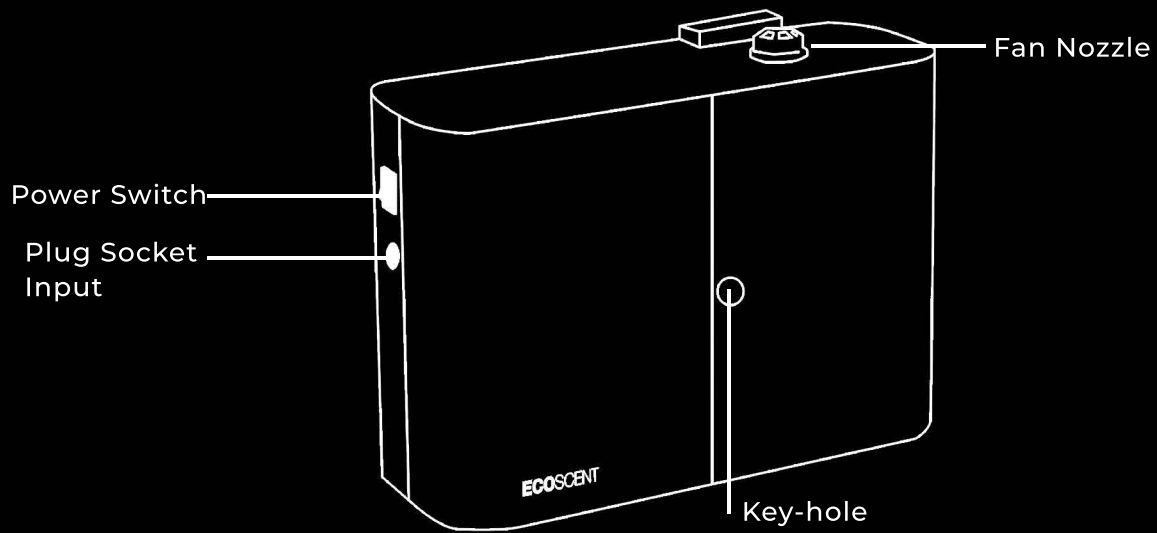

The scent unit can be floor standing or wall mounted.

- When wall mounting use the fixing screws enclosed and use the sticky hanging plate guide for accuracy.

- Avoid installing at eye level height. The scent system can be floor standing or wall mounted at low level. If installed at height allow 30cm distance from the ceiling.



POWER ON

Connect the power adapter with the 220V power socket and turn the unit on with the switch located at the side - you should hear a beep. Unlock the unit with the key, the fan should sound and LCD display screen should be on.

FRAGRANCE REPLENISHMENT

Open the machine's doors, unscrew the nozzle at the top right of the unit. Remove the bottle and fill with fragrance to your desired capacity. **Do not fill past the 750ml marked line on the side of the bottle.**

WORKING TIME SETTING

On the unit, press the   buttons simultaneously, and the screen will display the options to change the day and time. Using the buttons, adjust the date and time accordingly and press 'ENT'. Ensure the time and date input on the unit are in sync with the mobile device you will connect it to.

CONNECTING ECOSCENT UNIT TO AROMALINK APP

1) On the App Store, Google Play, or Android App Store search and download the AromaLink app.

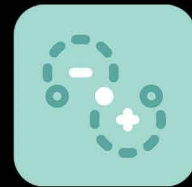

2) Open the AromaLink App, you'll see a Bluetooth button. Ensuring your unit is switched ON, click on the 'Bluetooth' button, the app will then search for nearby units. The device name will start with 'Smart.A5WIFI...' on the app select the device name and enter the initial password which is '1234' to connect your scent machine to your phone.

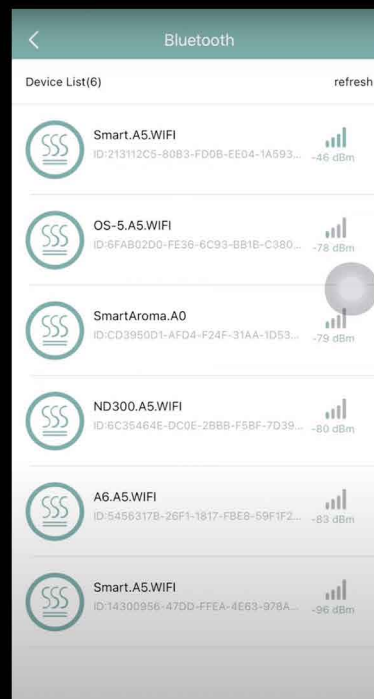
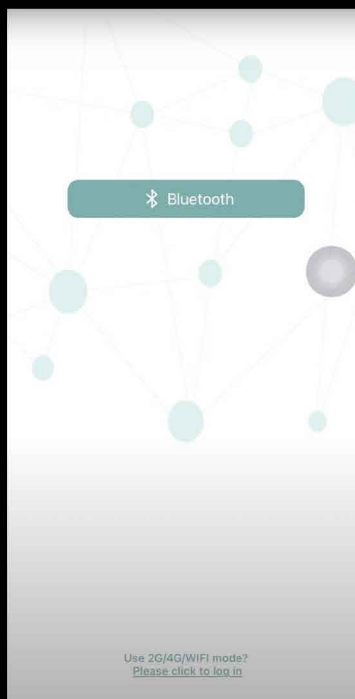

CONTROL INTERFACE

Your control interface should look like the image below

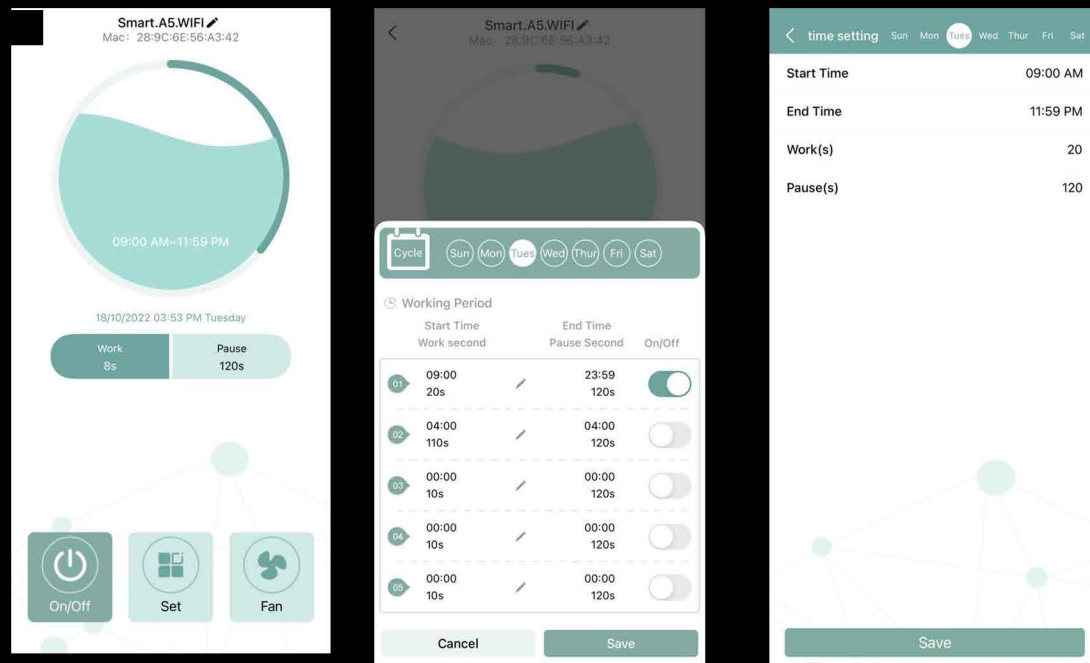

On/Off : Controls whether the scent machine is on or off

Fan : Controls whether the fan is open or closed. Turning on the fan allows the fragrance to disperse to a wider area.

Set : Allows you to set the working time period and frequency of the dispersal of the fragrance.

CONTROL BUTTONS EXPLAINED

On the main interface click the 'SET' button. To operate the working periods, select the days you would like the scent machine to function , below this area you can create your desired time intervals you want the machine to operate between. You can do this by pressing the  button.

SETTING THE FRAGRANCE CONCENTRATION

The scent system works from 5 to 300 seconds at a time and can be paused from 5 to 300 seconds per your requirements. The longer the pause, the weaker the fragrance. Please follow the guidelines below to setting your desired fragrance concentration. You can set up to 5 different programs.

CONCENTRATION %	WORK	PAUSE
100%	300s	5s
75%	225s	75s
50%	150s	150s
40%	120s	180s
25%	75s	225s
5%	5s	300s

SCENT DELIVERY SYSTEM MAINTENANCE

For scent delivery system maintenance advice please refer to our "Clean-Me Guide". Clean with a EcoScent cleaning solution every 2 months or if changing the fragrance. Do not use water in the scent system. Do not tilt the scent system. Please ensure the fragrance oil is replenished regularly.

TROUBLESHOOTING

FAULT	SOLUTION
SCENT DELIVERY SYSTEM IS NOT WORKING	<ul style="list-style-type: none">• Check the power supply.• Check if the power is on.• Check scent delivery system program settings.
WEAK OR NO ATOMISATION	<ul style="list-style-type: none">• Check if the nozzle is blocked• Check if the oil pump tube is attached correctly.
OIL LEAK	<ul style="list-style-type: none">• Check if the scent system is upright.• Check is the bottle washer isn't broken.• Check the connection of the oil bottle and atomiser is closed tightly.
ABNORMAL NOISE	Please send video of the fault to ecoscent@ecoscent.co.uk

SCENT SYSTEM NOZZLE CHANGE GUIDE

Before changing the nozzle try using the Cleaning Solution for 10 minutes, this will attempt to unblock any oil residue. Occasionally the nozzle can remain blocked and needs changing. Should your scent system be dispersing less or no fragrance you may need to change the scent dispersal nozzle. Follow the steps below.

STEP ONE

The nozzle is located in the top half of the machine which is connected to clear the tube, which is used to take the fragrance out the bottle.

STEP TWO

Gently remove the nozzle by pulling it out of scent delivery system. In case of the part being placed very firmly - use pliers to remove it. Some fragrance oil or cleaning solution may be present, ensure you take care of clothing and surfaces in case of any spillages.

STEP FOUR

Gently place new nozzle back in the scent delivery system and replace the clear tube.

ALL DONE!

You can sit down, relax and enjoy your favourite fragrance!

CLEAN ME GUIDE

It is important to regularly clean your scent delivery system with our EcoScent cleaning solution every couple of months to ensure the system runs smoothly and to prevent unnecessary internal damage.

STEP ONE



To clean the scent delivery system, ensure that fragrance oil bottle is empty then half fill with cleaning solution. Turn on the scent system to run as normal for 5-10 minutes.

STEP TWO



Turn off the power, pour out any residual cleaning solution and retain for future use.

STEP THREE



If the scent system is in constant use, the cleaning operation above should be carried out every 2-3 months to ensure ultimate efficiency of the atomised scent delivery technology.

If the equipment is not being used for a long period of time it is recommended that the fragrance oil bottle is emptied and the fragrance oil stored in a dry, dark, secure location. The scent system should then be cleaned with the cleaning solution as mentioned above. Please refer to User Manual for further information.

* Failure to clean the machinery will affect the warranty*

