

BAGNODESIGN

EXPERTLY CRAFTED BATHROOMS

Installation Guide

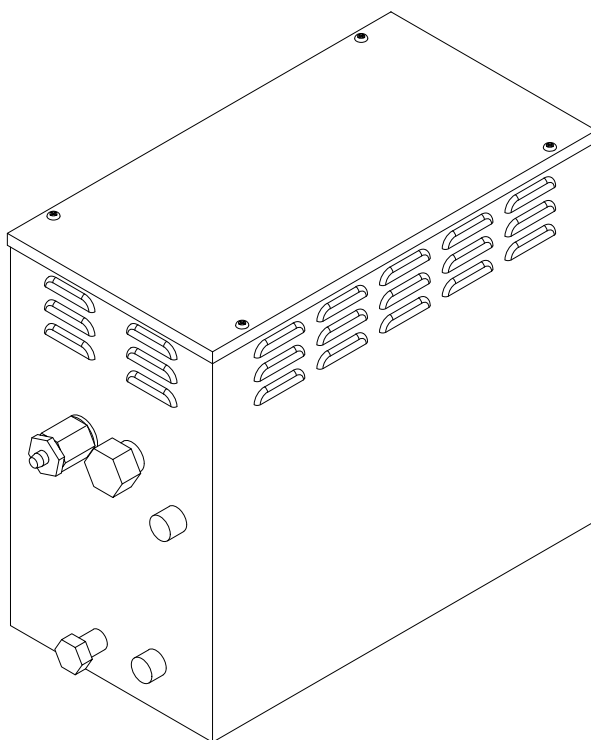

BDD-SPA-GEN9-3-A

BAGNOSPA STEAM GENERATOR 9KW 380V50HZ WITH DIGITAL CONTROL PANEL, BLUETOOTH MUSIC BOX, 2X SPEAKERS, WIFI BOX AND 4 RGB LIGHTS

A member of **SANIPEXGROUP**
www.sanipexgroup.com

Cataloge

Prologue-----1

Users instruction-----1

Choosing a right location-----1

Installation drawing of the steam generator-----2

Installation of pipeline-----3-4

Blueprint for the steam engine-----5

Electric requirements-----6

Installation of the top light-----7

Choose your type of machine-----8

Maintenance of the steam engine-----8

Configuration of steam generator-----9

Cleaning of the steam generator-----10

Cleaning process-----11

Trouble shooting-----11

Common troubles trouble shooting methods-----12

Ampere Meter-----13

Technical parameter-----14

Figure(Heating element and Power line assemble illustration)-----15-19

GEN9-3

Prologue

Welcome to use GEN9-3 series steam generator, this series contains a steam furnace and a controller. You can adjust the temperature of the sauna room and set the working time of the steam as you wish. And the system contains an overheat/dry-burnt protection system and a security valve could prevent the overheating and assure the steam furnace working at a regular air pressure. It has the reasonable design and working very stable, very convenient to install, healthy and comfortable, is the top grade sauna equipment for the modern family, hotel, restaurant, meeting place and the clubhouse will be satisfied with the noticeable effects on pain relief, weight control, skin stimulation and stress reduction due to an increased blood circulation got from steam bath.

GS08M series includes 9 types of machines that output power varies in 4.5kW, 6kW, 9kW, the users could choose it according to their requirements.

Users instruction



Caution: We are not responsible for the malfunction and damage came from the installation that not comply to the users manual.

1. Make sure the model and the accessories are correct, include the voltage input.
2. Make sure the steam power are matched with the sauna room' dimension. Pay much attention to the steam room's cubage and construction. If you have any problem, please refer to the Page 11 about the dimension selection.
3. Make sure to read this manual carefully for the secure and effective use.
4. We shall not be responsible for the product damage or malfunction caused by self-installation or the operation procedures which is not operated by the users instructions.
5. GEN9-3 series are packaged with a case, please check the goods when it arrived to assure it is in good condition, if you find any damage in the package, please contact the transportation company or the supplier to claim for compensation.
6. This product must be used indoor.

Choosing a right location



Important: Install an exhaust fan outside of the steam room in case that it can expel the excessive steam from the shower room.

Some locations recommended to customers for the right installation.

1. The distance to the steam room less than 6m, the standard pipe which link the controller and the steam generator should be 6.5m.
2. The steam generator should not be installed in the steam room
3. Not installed outdoor or in any places that will influence the security of the machine by the environment.
4. Do not install it in the frigid loft or any places the water will freeze.
5. Do not install it near the burnable and caustic object or chemical (coal gas or dope thinner etc.)
6. Installed in a dry place and the ventilation is good.

7. Stable and horizontal. The steam generator has a hanging groove for immobility on wall. Make sure the machine is steady and horizontally installed.
8. On both sides and the top of the steam generator need to reserve at least 12 inches space.
9. The place where the machine is installed must be easily cleaned up and convenient for the disassembly of the machine.
10. The installation place must be convenient for the drain of water in inner pot.
11. The steam tube, safety valve, drain valve, water tube, steam outlet are still very heated after the steam generator have stopped working for some time. Must take some measures for example using the heat insulation tube to prevent the damage of the hot tube and keep the outlet away from the people.
12. The controller must be installed in the steam room, please refer to the chapter instruction of the controller's installation and operation of the manual.



Attention: *The steam generator (including the controller) are comply with the CE and UL certificate, and are adaptive in the moisture environment.*

Installation drawing of the steam generator



Attention: The drawing is only for explanation. As for practical design of steam room, please consult with qualified designer or architect.

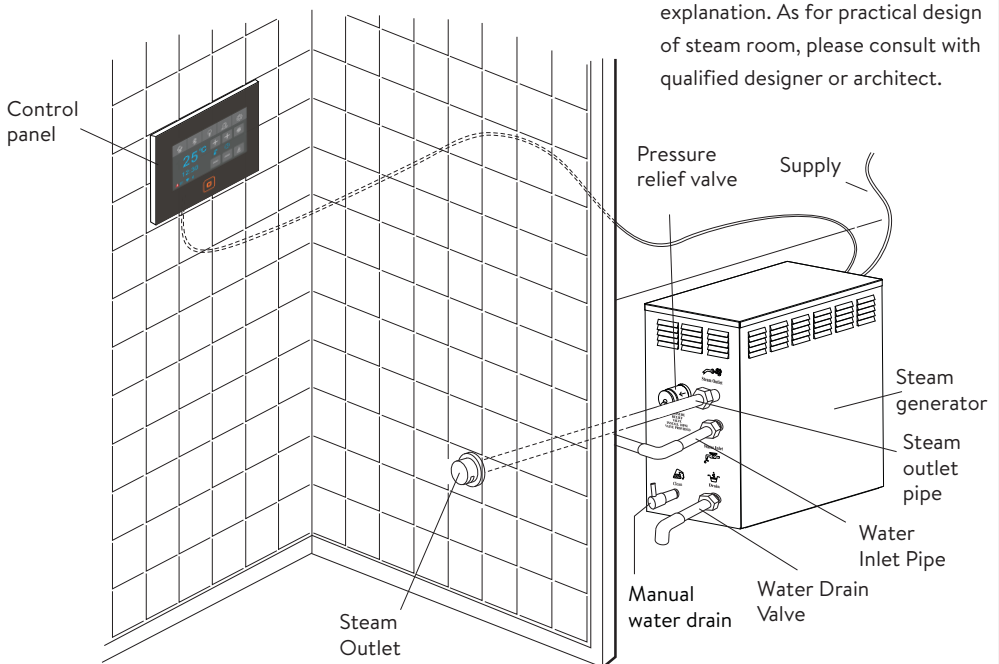

Installation of pipeline:

 **Warning:** The installation of all the pipes should be operated by qualified plumbers with corresponding operation certificate in accordance with national requirements:

1. Use joints when connecting pipes.
2. Use brass pipes or copper hoses only.
3. Do not use black and galvanized or PVC pipes.

Water supply pipe (1/2")

1. Connect hot water or cold water pipes. It had better be hot water pipe with a temperature no more than 70°C.
2. Install stop valve in the water supply pipe. The stop valve should be installed in a place where it is easily operated in emergency.
3. Clean the water supply pipe completely before connecting the water pipe to the steam engine.
4. It is suggested that filter and anti-furring equipment in the water supply pipe.
5. The water pressure should be at best between 15 and 20 pounds/square inch. If necessary, decrease the pressure accordingly.
6. If necessary, install equipment to prevent the water producing sound.

Steam pipe (4.5kW pipe size:1/2"; 6kw & above:3/4")

1. Do not install any valves in the steam pipes. The steam can never be obstructed.
2. Install a brass steam pipe(4.5kW pipe size: 1/2"J 6kw & above:3/4") between the steam outlet and the steam nozzle.
3. The heat insulation material used to insulate the steam pipe should be resistant to temperature as high as 120°C or higher.
4. The horizontal part of the steam pipe should be installed inclining to the steam outlet or in the direction of steam engine. Do not bend it in a hape to make sure that the cooled water will not stay in the curved pipe of the steam pipe.
5. The shorter the steam pipe, the better. Try to decrease the number of elbows and avoid abrupt turns.

 **Attention:** Do not install the steam pipe in an upper or lower direction now and then, which will affect the output of steam.

Steam nozzle (4.5kW pipe size: 1/2" J6kw & above:3/4")

 **Attention:** Since the steam nozzle and steam outlet are very hot, try to avoid install the steam nozzle in the position which will easily come into contact with the person in a bath in case the steam should splash to scald the user.

1. Install the steam nozzle in the position 6-12 inches above the ground. If the steam bath is in the bathtub or bathroom, install the steam nozzle 6 inches above the bathtub. If the steam room above adopts materials like acryl or non-heat-resistant sheet, install additional heat insulator.
2. The steam spray outlet should be installed face down. Wind a few circles of green material belt around the whorl of the steam pipe, install the steam nozzle and tighten with hands.

 **Attention:** In order to protect the steam nozzle, do not use the spanner or other tools to tighten, use a little soap water and soft sponge to wipe, and do not use erosive chemical solutions or crude cleaning tool.

Important:

1. Please consult your distributors of building materials like acryl, fiber glass or other anti-heat sheet about the installation position of steam nozzle.
2. In the entire steam room, it is required that steam can not leak out. The pipes, its accessories and the holes in the wall should be air proof by applying air proof glue so that no steam will enter the holes in the wall.

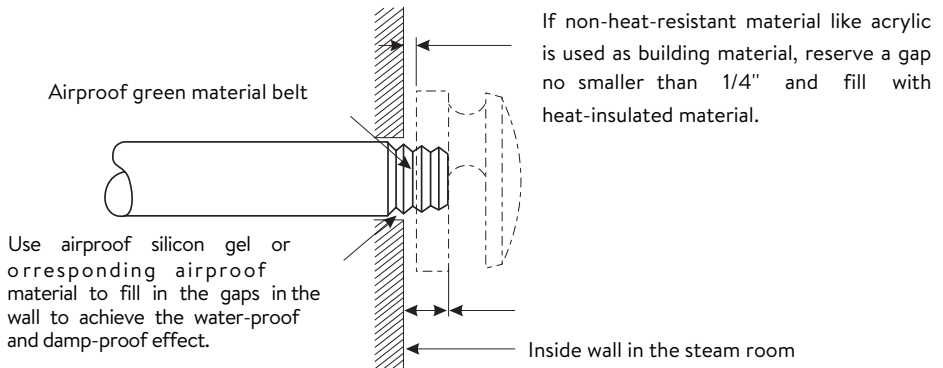

Drainpipe (1/2")

According to national or local rules, the steam engine drainage valve should be equipped with drainpipe. The steam engine drains the water by using weight.

 **Attention:** The drainpipe should not incline upwards so as to facilitate the drainage of water.

Safety valve

1. Safety valve is a piece of safe equipment in order to prevent too much steam pressure in the interior steam engine due to various reasons.
2. The pressure limit range of safety valve is 15 PSI and the pressure will begin to decrease if pressure should come over this value.
3. If it is allowed by local codes, provide the safety valve with exterior drainpipe.

Warning:

1. Do not dismantle the pressure decrease valve at random in case any danger should happen.
2. To maintain the proper and automatic operation of safety valve, make sure the safety valve connection pipe is smooth.

GEN9-3

Blueprint for the steam engine

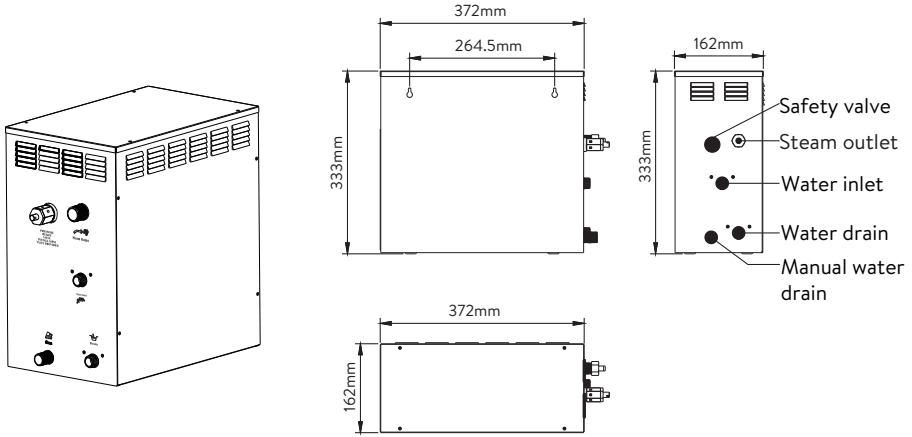

4.5KW

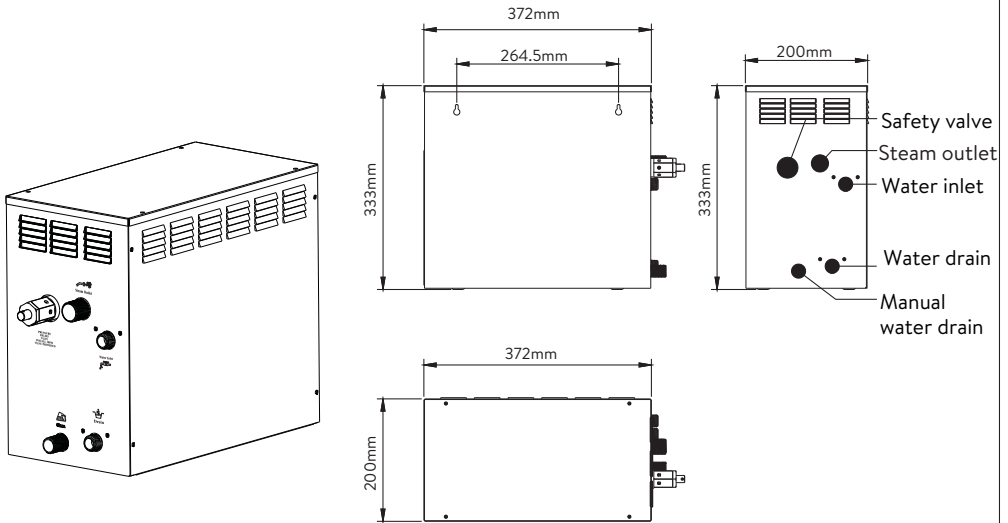

6KW/7.5KW/9KW

Attention: To facilitate maintenance, keep the steam engine clean. If the information provided is limited, do not operate on the pipeline and electric equipment arbitrarily as shown in the figure for proportion.

Caution: To avoid damage to the equipment, do not connect strong electric current directly to the components

Electrical requirements:

Electricity supply circuitry:

1. Test the voltage of electricity supply and make sure steam engine with suitable electric voltage should be used..
2. Insulated copper wire should be used with an anti-heat temperature of 90â„ƒ and a specified voltage of 500V. Refer to national or local electricity consumption code for the specifications. Refer to the ammeter for the ampere.
3. Choose steam engine with suitable item number, and plug the ground wire into the ground terminal.
4. Install an independent circuit breaker between the power supply and the steam engine so as to provide an electricity supply with overflow protection and electricity leakage protection.



Attention: All the connection must be in accordance with national and local electricity consumption code and be installed by professional electricians.

Installation of the top light



CAUTION:

Light is available in 12V/220V/230V outputs. Before connect to the light, please consult with manufacturer to know what voltage the light is, so as to avoid generator damage or cause danger.

If the light output is 12V, the power of the light should not be more than 35W,otherwise, transformer will be burned and cause danger. If light input is 220v~240V,light power should not more than 100W.

The light should be installed on the top of the steam room or the places where are not access to the children.



CAUTION:

Take some moisture proof measures in process of installation. Can not let the electrical components be exposed to moisture or, it will cause damage or short circuit.

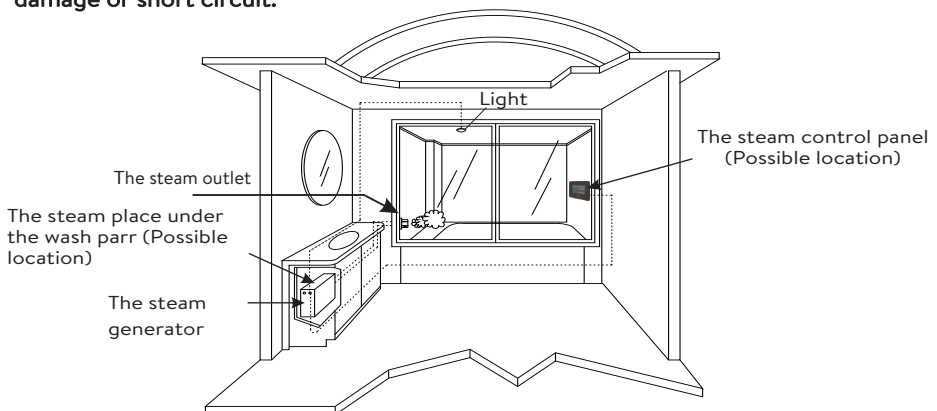

CAUTION:

The illustration is just for explanation, the practical installation must comply with the nation's electric criterion,and processed by the professional

Choose your type of machine

Measure the length, width and height (foot) of the current steam shower or bathtub room.

Example;

L:7xW:5xH:8 = 280 Cubic Feet

You would need Model s-900 (it is that simple)

However, if you shower materials are;

| | | |
|---|-----|-----|
| A:Natural Stone(Granite or Marble etc.) | ADD | 75% |
| B:Exterior walls | ADD | 75% |
| C:Celia Heights exceeding 8 FT. | ADD | 75% |
| D:Ceramic tile | ADD | 75% |
| E:Glass (2 walls) | ADD | 75% |

 **Important:** The calculation formula for selecting the type of steam engine is for reference only. Due to the variability of the building, the specifications and size illustration are used as guidelines only. If we have complete information, including actual blueprint, project instruction and building details, we can select the type of machine once again. Otherwise, the manufacturer will not be responsible for the selection of the type of machine.

Maintenance of the steam engine

 **Important:** Perform water discharge operation after each use.

1. Wait for the completion of automatic water discharge after each time of using the steam engine to make sure the water in the tank is discharged completely before cutting off power supply.
2. There should not be any leakage or damage among the steam engine, steam nozzle, components and pipes. They should be checked and repaired annually.
3. Clean the water supply pipes of the steam engine once a year.
4. Check all the connections, faucets and connection terminal to see whether they become loose or are damaged due to overheat.
5. Check the furring accumulated in the water tank and electric heating tube. If the furring is thick, dispose it in time (use diluted lemon acid to soak for 15-30 minutes).
6. Remove the water level sensory needle once a quarter to clean the furring in the needle.

Configuration of steam generator

9KW

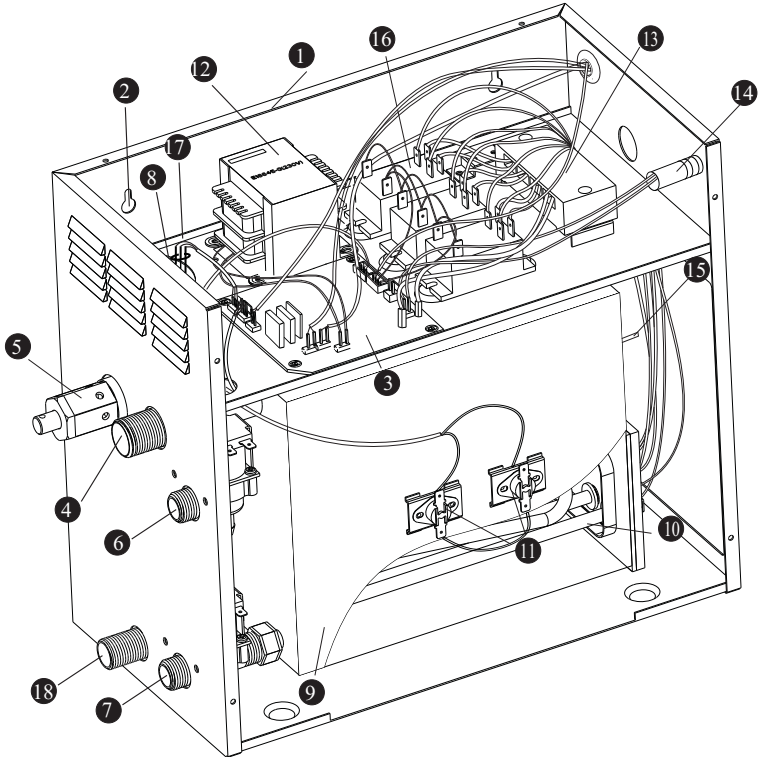

- | | | | | | |
|---|-----------------------|----|-----------------------|----|----------------------|
| 1 | Enclosure | 7 | Water drain valve | 13 | Terminal block |
| 2 | Insulation bracket | 8 | Subsidiary water tank | 14 | Fuse |
| 3 | Circuit board | 9 | Main water tank | 15 | Earth wire connector |
| 4 | Steam Outlet | 10 | Heating Element | 16 | Relay |
| 5 | Pressure relief valve | 11 | 105°C Hi-limit | 17 | Water level sensor |
| 6 | Water fill valve | 12 | Transformer | 18 | Manual water drain |

Cleaning of steam generator

Manual cleaning

1. Before cleaning the water tank, please be sure to drain water inside tank completely.
2. Power off the steam generator, put some oxalic acid (crystal state) via steam outlet, for example, GEN9-3 9KW water tank need about 220g oxalic acid with 500-800ml hot water; pls be sure that the manual water drain ball valve switch off this time.
3. After putted the oxalic acid inside tank, get power supply to steam generator but no turn it on. Pressing Fly shuttle button for 2seconds, system will enter into the cleaning procedure, water will fill the water tank automatically. TEMP window on panel shows "hot", 59 minutes countdown time begins and show on Timer window. steam generator will heat up water inside water tank two times in this period automatically and get water scale peeling off, when from element and water tank. When timer window shows countdown time is "00:00",TEMP window shows "opl" from "hot", pls switch on the manual drain ball valve at this time to drain the water from water tank. When system detect lack of water for 1 minute,system will switch on the water inlet valve to get water supply to water tank so as to continue cleaning water scale inside tank for 1 minute and drain water from manual water ball valve. After finishing cleaning, system quite the cleaning mode automatically. When TEMP window shows "opl", if you don't switch on the manual water drain ball valve, the control panel keeps waiting till the ball valve switch on or press the power on/off to quit cleaning function.
4. Water tank of steam generator should be cleaned in every 3 months, if the water is hard, suggest to clean it every 2 months so as to extend the lifespan of heating element and water tank.
5. The cleaning water must be drained through manual water drain ball valve, otherwise, scale will jam the Auto. water drain valve.

GEN9-3

Cleaning process

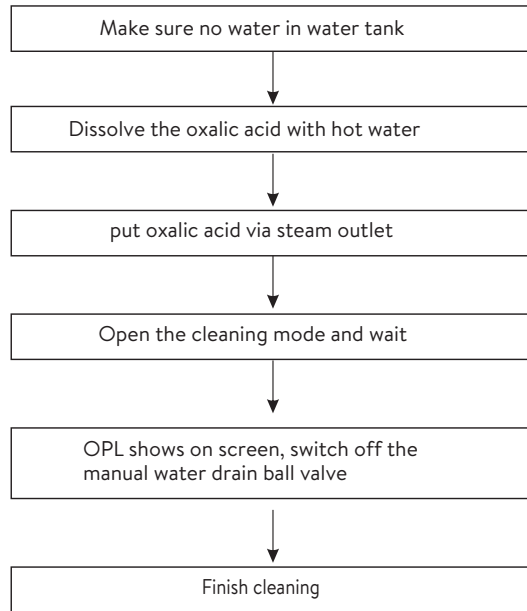

Trouble Shooting

E0: The temperature sensor open circuit.

Water level sensor failure, checking the control cable connection between the control panel to steam generator is loose or not.

E02: The temperature sensor is Short circuit

E03: Signal transfer fault between main panel and sub-panel .

E04: Signal transfer fault between control panel and steam generator.

E12, E22, E32, E42: water inlet takes over 2 minutes

E13, E23, E33, E43: water inlet tank block.

E15, E25, E35, E45: Auto. high limit trips.

Common troubles trouble shooting methods

To facilitate your use and maintenance of sauna room, the following common troubles trouble shooting methods are listed for identification.

| Troubles | Causes of troubles | Trouble-shooting methods |
|--|--|--|
| The machine does not start when electrified | <ol style="list-style-type: none"> 1. The fuse is burned. 2. The wire connection terminal become loose. 3. Not good contact in the connection wire between the controller and the steam engine. | <ol style="list-style-type: none"> 1. Change the fuse (on the shell 0.8A/ 250V) 2. Plug tight the wire connection terminal 3. Make sure the steam engine and the controller come into good contact |
| Electricity leakage switch breaks automatically | <ol style="list-style-type: none"> 1. The wire connector is dampened or damaged. 2. The heating tube breaks | <ol style="list-style-type: none"> 1. Check whether the wire connector is dampened or damaged, and dry with dryer if dampened. 2. Change a heating tube. |
| When the machine is started, hot water comes out with little or no steam | <ol style="list-style-type: none"> 1. The water drainage valve is broken. | <ol style="list-style-type: none"> 1. Change a water drainage valve. |
| The display screen on the control panel does not display | <ol style="list-style-type: none"> 1. The power wire is not connected well or not in good contact. The connection plug between the control panel and the electrically-controlled box becomes loose. 2. Trouble with plugboard. | <ol style="list-style-type: none"> 1. Check whether the connection plug between the control panel and the electrically-controlled box has become loose, and whether the power circuitry has good contact. 2. Change a plugboard. |
| Water leakage | <ol style="list-style-type: none"> 1. The water pipe connector becomes loose or the pipe breaks 2. Water leakage in the water input valve or the water drainage valve | <ol style="list-style-type: none"> 1. Tighten the loose connector, and change the broken pipe. 2. Change the water input valve or the water drainage valve. |
| No steam when starting the machine | <ol style="list-style-type: none"> 1. No electricity. 2. No water. 3. The set temperature is too low 4. Trouble with wire. | <ol style="list-style-type: none"> 1. Check the power supply 2. Check the water input pipe and water input valve 3. Reset the temperature 4. Contact the distributor |
| The steam does not come out, the water sounds in the machine | <ol style="list-style-type: none"> 1. The steam pipe is jammed. | <ol style="list-style-type: none"> 1. Cut power supply to check whether the steam pipe is smooth. |
| The light can not be turned on | <ol style="list-style-type: none"> 1. The fuse is burned. 2. The light is broken 3. The wire is broken 4. The plug does not have good contact | <ol style="list-style-type: none"> 1. Change the fuse (on the shell 1A/250V) 2. Change a light bulb. 3. Change wire. 4. Make the contact good. |
| The display box displays normally with no steam input | <ol style="list-style-type: none"> 1. Too much pressure inside the steam engine, so the system breaks for heat protection. 2. Wire is broken for heat protection. | <ol style="list-style-type: none"> 1. Check the steam transport pipe and restore automatically after heat protection becomes cool. 2. Check the heat protection wire to make sure the connection is good. |

Ampere Meter

| Type | Applicable space of the room (m ³) | Electricity supply | Max. Electric current (A) | Specifications for power wire |
|--------------|--|----------------------|---------------------------|-------------------------------|
| GEN9-3-4.5KW | 4 ~ 7 | 220-240V ~ (1PH/2PH) | 20.5A | 12# or 4.0mm ² |
| GEN9-3-6KW | 5 ~ 8 | 220-240V ~ (1PH/2PH) | 27.3A | 10# or 6.0mm ² |
| | | 208V ~ (3PH) | 16.7A | 12# or 4.0mm ² |
| | | 380-415V ~ (3PH) | 9A | 12# or 2.0mm ² |
| GEN9-3-9KW | 10 ~ 12 | 220-240V ~ (1PH/2PH) | 41A | 8# or 8.0mm ² |
| | | 208V ~ (3PH) | 25A | 12# or 4.0mm ² |
| | | 380-415V ~ (3PH) | 13.7A | 12# or 2.0mm ² |

The data provided above are for 220-240V(1PH/2PH), 208V(3PH) and 380-415V(3PH).

Within the eyeshot of the steam engine, install an independent circuit breaker so as to provide an electricity supply with overflow protection and electricity leakage protection.

Important: *The list above is for reference only. In actual checking and repairing, based on the national and local codes, ask professional service personnel to operate.*

Technical parameter

TYPE GEN9-3

| | | | | | | | | |
|--|---------|---------|---------|---------|---------|---------|---------|---------|
| Power Output | 4.5KW | 6KW | 7.5KW | 9KW | 10.5KW | 12KW | 15KW | 18KW |
| Potency Error | ±10% | ±10% | ±10% | ±10% | ±10% | ±10% | ±10% | ±10% |
| Duration | >1500V | >1500V | >1500V | >1500V | >1500V | >1500V | >1500V | >1500V |
| Resistance | >20MΩ | >20MΩ | >20MΩ | >20MΩ | >20MΩ | >20MΩ | >20MΩ | >20MΩ |
| Steam Pressure | 0.12Pa | 0.14Pa | 0.14Pa | 0.14Pa | 0.16Pa | 0.16Pa | 0.16Pa | 0.16Pa |
| Steam Volume ml/min | 160 | 180 | 220 | 260 | 300 | 360 | 450 | 500 |
| Steam Production Time (S) | 180-240 | 150-220 | 140-200 | 130-190 | 200-260 | 180-240 | 150-240 | 130-190 |
| Water Tank Volume | 2.5L | 3.5L | 3.5L | 3.5L | 7.5L | 7.5L | 7.5L | 7.5L |
| Applicable space of the room (m ³) | 4~7 | 5~8 | 7~9 | 10~12 | 12~14 | 14~16 | 18~20 | 20~24 |

Important: The parameter listed in the table will be varied from different place and temperature, please consultate to the qualificatory designer and architect for the more detailed use.

Figure(Heating element and Power line assemble illustration)

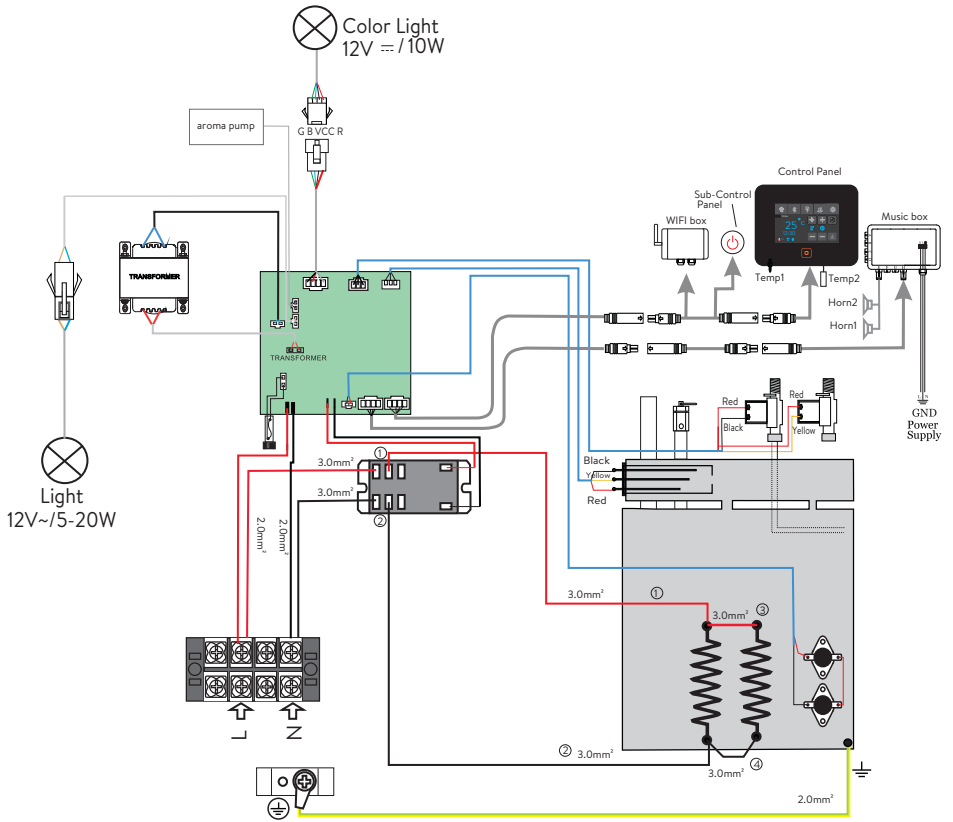

Internal wiring diagram of steam generator

4.5kw (220-240V/1phase)

Figure(Heating element and Power line assemble illustration)

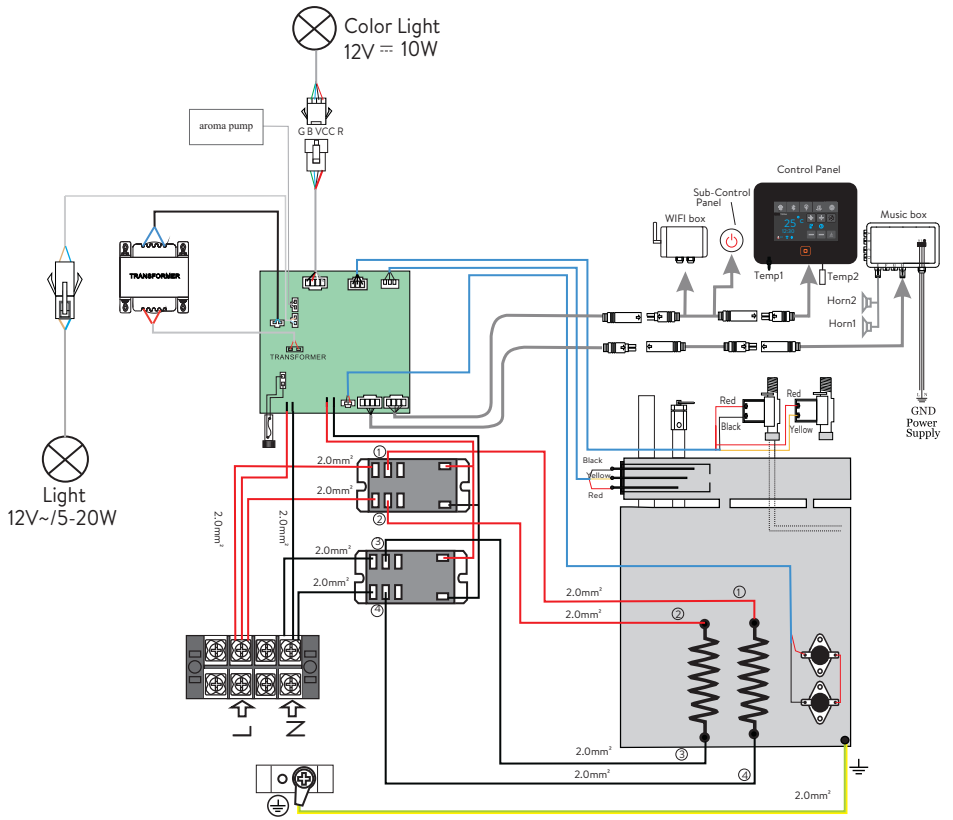

Internal wiring diagram of steam generator
6kw (220-240V/1phase)

GEN9-3

Figure(Heating element and Power line assemble illustration)

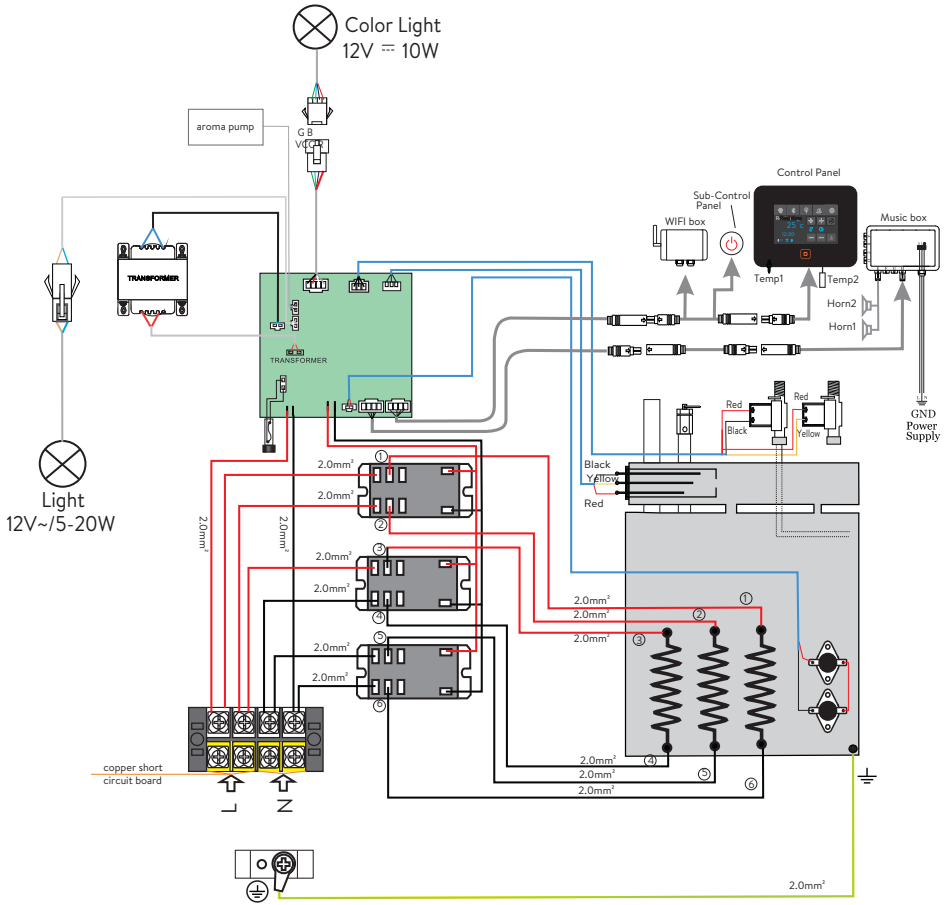

Internal wiring diagram of steam generator
7.5-9kw (220-240V/1phase)

Figure(Heating element and Power line assemble illustration)

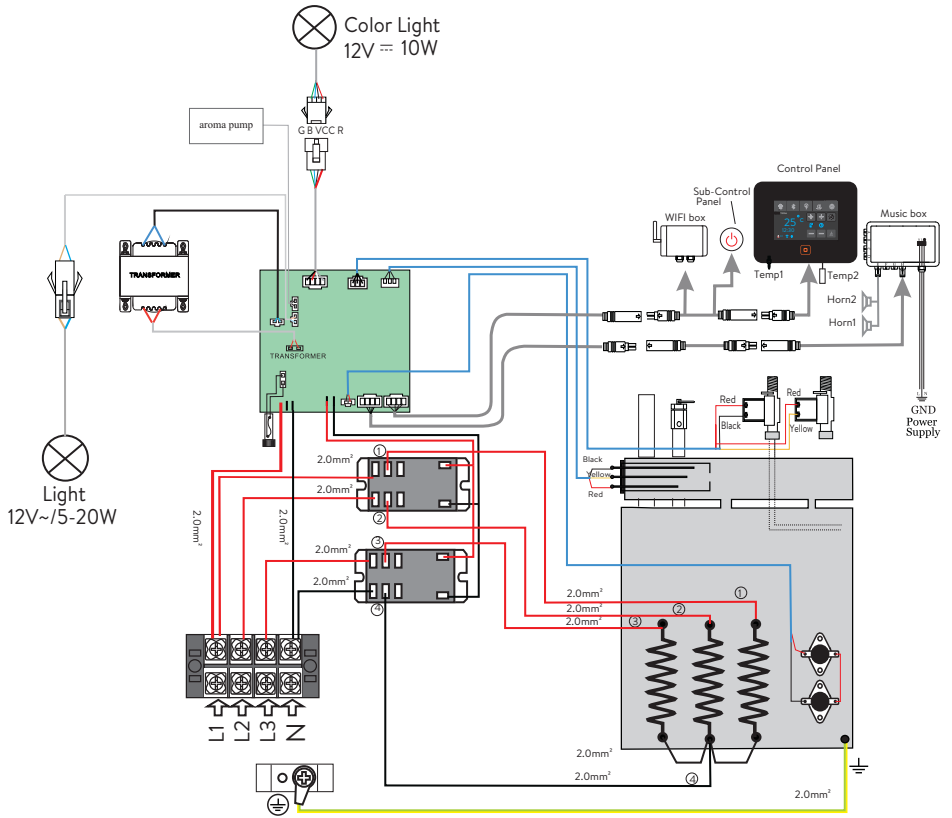

Internal wiring diagram of steam generator

6-9kw (380-415V/3phase)

BAGNODESIGN

EXPERTLY CRAFTED BATHROOMS

A member of SANIPEXGROUP
www.sanipexgroup.com