

## AromaSense Option Model:

The AromaSense optional pump system is designed to work exclusively with the BD SPA generators and BD SPA controls.



**Warning:** AromaSense oils are not for oral consumption and should not be applied to the skin. Keep the AromaSense oils and the AromaSense pump out of the reach of children. AromaSense oils are not a cure or treatment for any medical conditions. Elderly persons, pregnant women, or those suffering from heart disease, high blood pressure, diabetes, or who are otherwise not in good health, do not use this device unless directed to do so by a physician. Also do not use the steam bath while under the influence of alcohol.

1. Access screw to connect the control cable (center top).
2. Peristaltic "Pump 1" (left).
3. Peristaltic "Pump 2" (right).
4. Manual forward and reverse switch for Pump 1.
5. Manual forward and reverse switch for Pump 2.
6. Peristaltic pump rollers.
7. Black peristaltic pump tube.
8. Clear Discharge tube (tube on right side of each pump).
9. Clear Suction tube (tube on left side of each pump into canister).
10. Canister Caps drilled with 1.5mm holes.
11. AromaSense Bottles (purchased separately).
12. Bottle clips to secure essential oil canisters.
13. Tube Fitting.
14. AromaSense Adapter plug ¼ NPT.
15. Aroma Injection Tee: ¼ copper X ¼ copper X ¼ NPT.

Figure 1: AromaSense Module

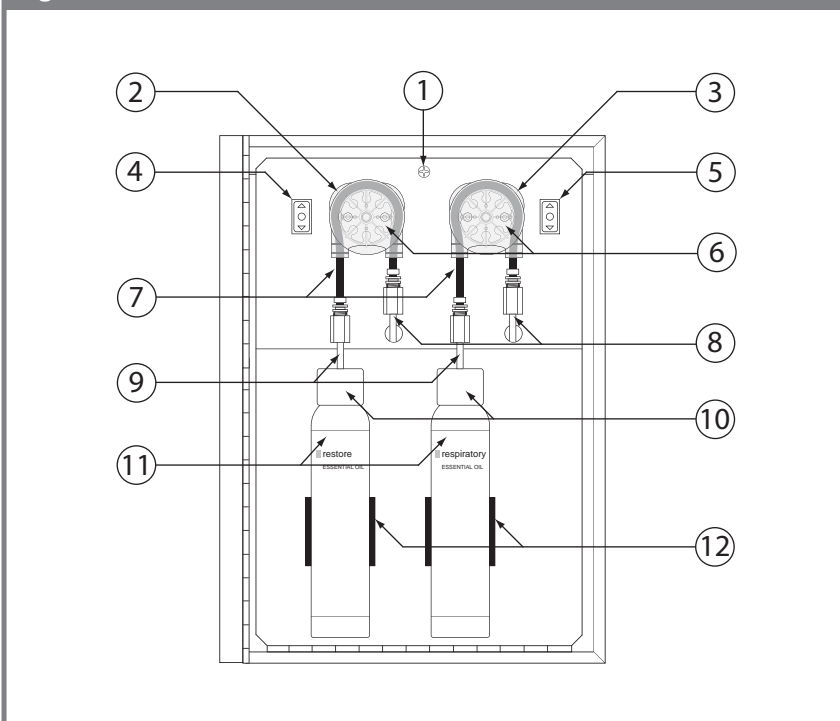
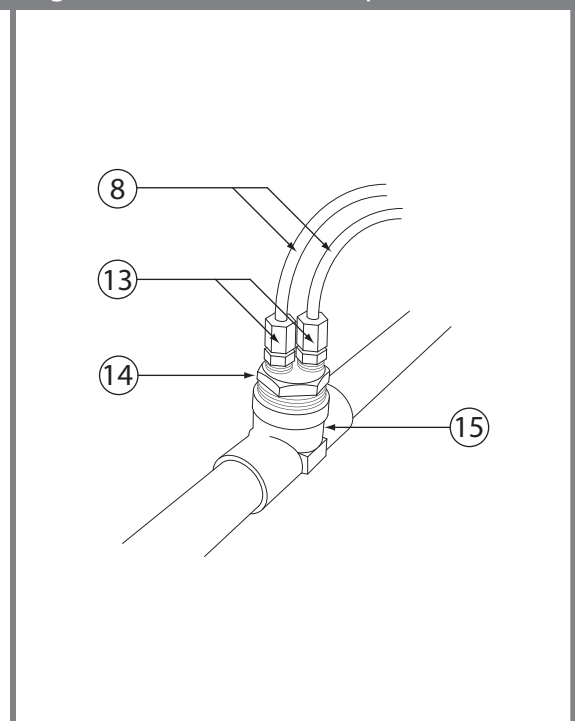

Figure 2: AromaSense Adapter



### Installation Instructions

1. Select a location for mounting the AromaSense Module system in a utility area or closet near the steam room. The oil is injected directly into the steam line with an Aroma Injection Tee (15) going to the steam head. The distance from each pump to the tee should not exceed 1.8 meters. This tee and the clear tubing (8) that carries

the oil to the tee (15) must not be installed inside walls. This tubing and tee must be completely accessible for proper setup. Do not install any part of this assembly in a wall. The location may be above or below the steam line connection. The location should be convenient for replacing the oil canisters.

Installation Instructions

Figure 3 - Installation

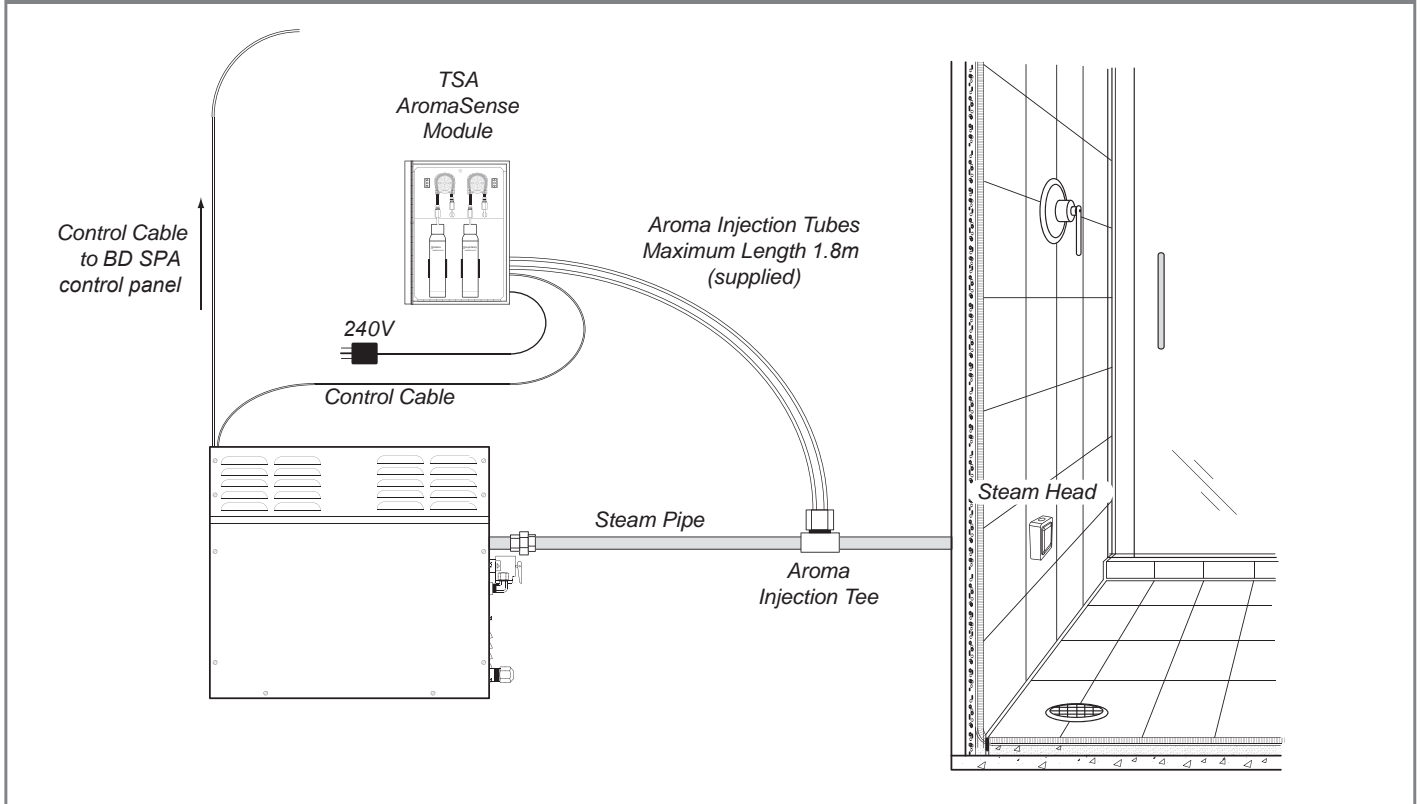

2. Make sure a 240 volt outlet is located next to the AromaSense Module mounting location.
3. Secure two screws in the wall to hang the AromaSense Module in this location. The screws should be placed 125mm apart and level.
4. Route the control cable from the AromaSense Module location to the BD SPA generator (or optional AudioSense, ChromoSense ). The manners in which the cables are routed are dependent on what is best suited for the installation. There are three connection jacks in BD SPA generator(s) and two in the AromaSense, AudioSense and ChromoSense allowing for gangable connections in the most convenient arrangement. The manner in which everything is interconnected is not important only that everything is interconnected.
5. Choose a location for the tee. The location is preferable to be level with, or above the steam head. DO NOT install the tee below the steam head. This will provide a better aroma flow to the steam room and prevent backflow of oil to the generator. When the steam generator outlet is located below the Steam head make a minimum of a 25mm riser in the steam line located between the steam generator and the aroma injection tee see (Page 3, Figure 5). This will prevent the aroma oil from backing up into the generator. The location of the tee must remain accessible after the installation is complete. The injection tee is not intended to be buried in the wall. Make sure the plastic fittings are removed before the sweating the tee in place. Sweat the tee into the steam line in the horizontal position shown. Do not install in any other position.

Figure 4

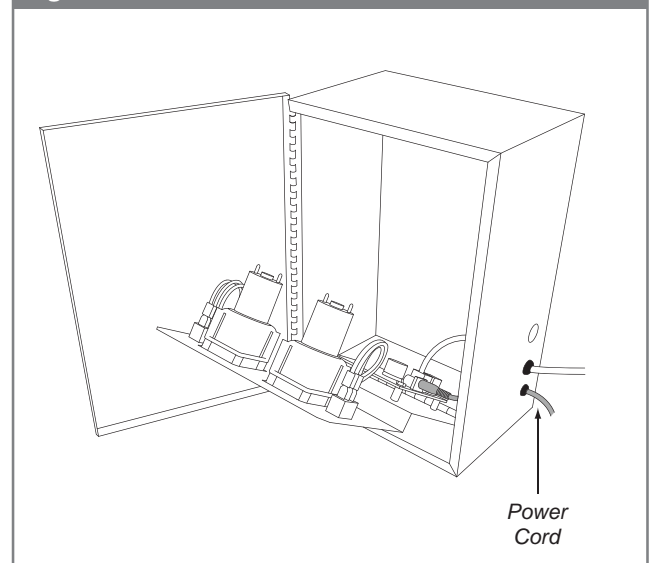

6. Plug the power cord (supplied) into the AromaSense Module's circuit board (shown in Figure 4 and Figure 8) and to an outlet. Make sure the pump rollers spin (6) when the switches are pressed on the AromaSense Module. If the pump does not spin check that the power supply is securely plugged into the pump control circuit board located behind the pump panel.

Assembly and Setup

Figure 5

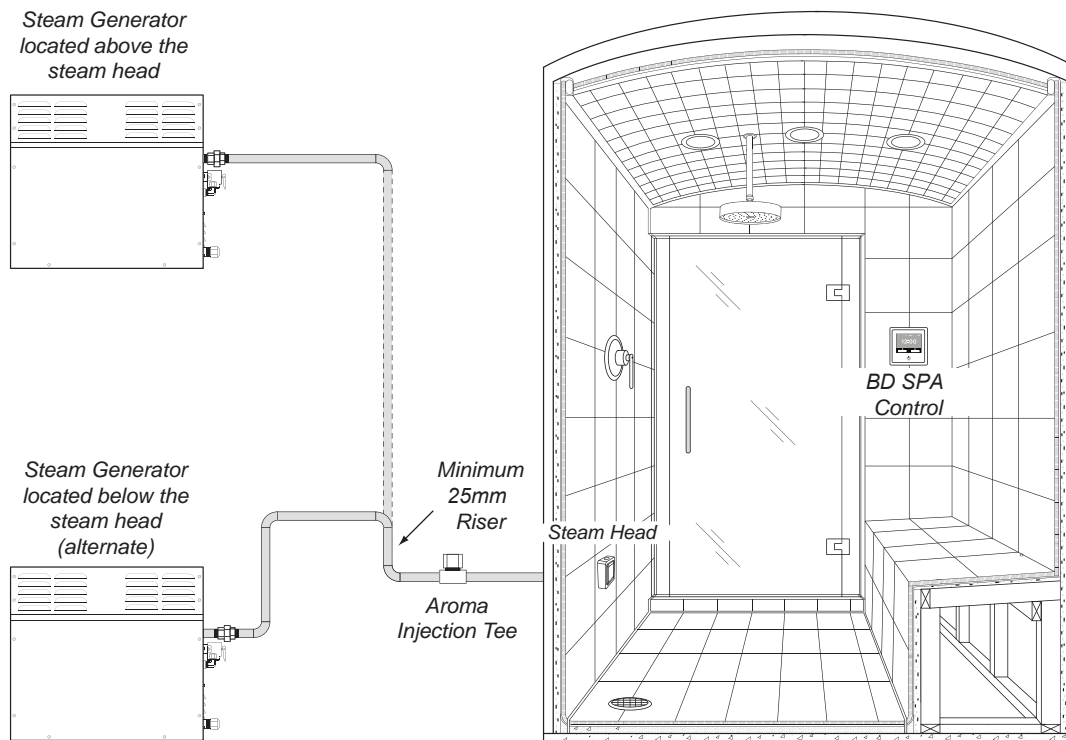

**Assembly and Setup**

1. The black peristaltic tube (7) needs to be installed into the pumps.
  - a. Remove (unsnap) the blue plastic cover exposing the pump roller assembly.
  - b. Pull out the Rotor about a 15mm
  - c. Place the tube between the pump base and each of the rollers forming a loop where the tube follows the inside upper curve of the pump base.
  - d. Push the lower right and lower left ends of the black tubing into the blue pump base securing it in the provided groves.
  - e. Replace the blue cover on to the pump base. Verify that the pump cover is properly attached to the pump base so that there is no space and the pump cover is not crushing the tube.
  - f. Repeat the above procedure for the second pump.

Figure 6

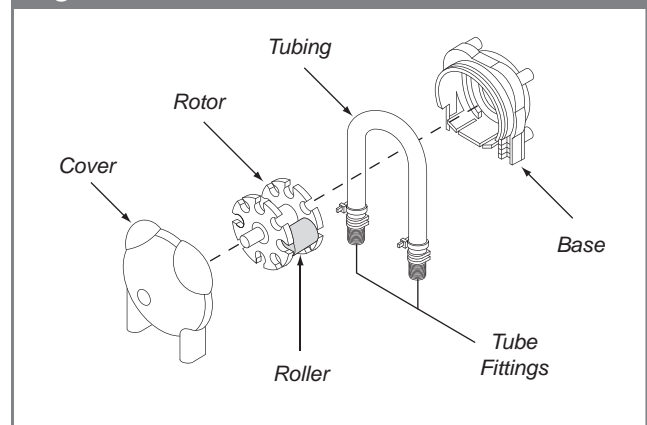
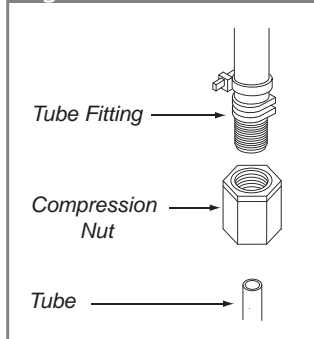

Figure 7



2. Clear Tubing connections: The clear tubing that is used to carry the oil to the steam line is secured with special 5mm tubing fittings. These fittings are assembled by sliding the tube through the nut and bottoming the tube into the fitting. Then tighten the nut until the tube is secured.
  - a. With the bottles removed the clear suction tubes should extend from the left side of the pump to the bottom of the cabinet. This will ensure that when the bottles are in place the tube extends to the bottom of the bottle. Connect the clear tube to the black peristaltic tube on the left (inlet) side of each pump.
    - b. Connect the outlet side of each pump (right side) to a length of clear tube that will be long enough to reach the tee connected to the steam line.
    - c. Route the tube through the hole in the front pump panel and out the hole in the right side of the cabinet to the tee.
    - d. Connect the tube for each pump to the fittings on the tee adapter. (See Figure 2).

Assembly and Setup

**Replacing the AromaSense Bottles**

1. The AromaSense canisters are shipped from the factory sealed and the caps supplied with the oil do not have a hole in them for the inlet tube. The AromaSense pump system is supplied with two predrilled caps. These caps should be saved and reused. Should these caps be lost it is simple to modify any new cap by simply drilling a 1/8" hole into the center of a new cap. Replace the caps on the canisters with the predrilled caps. Do not leave the bottles open without the caps as this will evaporate the oil.
2. Insert the inlet tubes all the way into the caps and snap the bottles into place.
3. Press and hold the up button to prime the pump system. You will see the oil travel through the tube. Keep pumping the oil until the oil in each tube reaches the tee in the steam line. It is ready to go.

Figure 7: AromaSense Cannisters

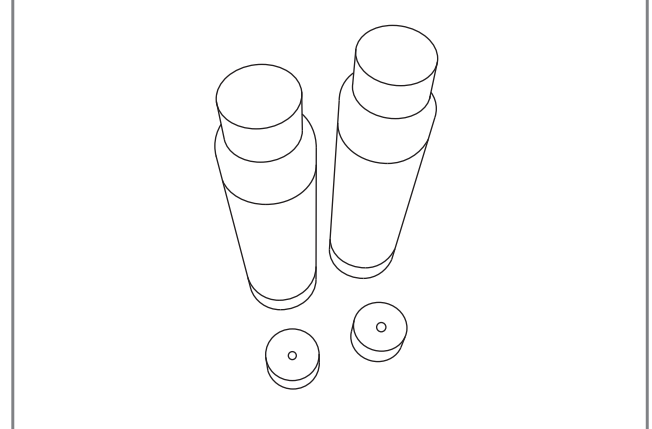

Figure 8: Wiring Diagram

