

## AudioSense Option

**IMPORTANT:** The AudioSense option is designed to work with the BD SPA generators and BD SPA control.

## Control Module Installation

- 1) Select a location for mounting the AudioSense module in a utility area or closet. The AudioSense has audio input jacks on the side of the module that should be conveniently accessible to plug in additional audio inputs. Do not install any part of this assembly in a wall.
- 2) Secure to the wall with screws.
- 3) Make sure a 240 volt outlet is located next to the module mounting location. Plug the power cord after all connections are complete.
- 4) Route the control cable from the module location to the BD SPA generator, or optional ChromaSense and/or AromaSense. The manners in which the cables are routed are dependent on what is best suited for the installation. There are multiple connection jacks in BD SPA generator(s), two in the AromaSense, two in the ChromaSense, and two on this module allowing for gangable connections in the most convenient arrangement (See figure 3 for the system wiring diagram).
- 5) The AudioSense option requires speakers which are purchased separately. Refer to the wiring diagram on figure 3 for connecting the speakers to the control module.

## Indicator Lights / Troubleshooting

1. **Green Light: Power Light.** This along with the blue and yellow light will flash momentarily when the power is first plugged in. This flash indicates the microprocessor is functioning and is a test for the lights.
2. **Yellow Light: Communication Light.** This light is an indicator that the AudioSense system is not communicating with the control. After the initial power up the light will continue to flash until communication is established with the BD SPA control. To establish communication, power to the BD SPA control must be turned on or if power is already on, go to the BD SPA control and start a steam or shower cycle for a few seconds then stop or cancel the cycle. This will make the BD SPA control look for the audio system and establish communication. When the AudioSense module is communicating with the BD SPA control this light will be off.
3. **Blue Light: Bluetooth light.** This light will be on steady when the Bluetooth signal is broadcasting and not paired with a device. When it is paired it will flash and when it is off it means that Bluetooth is turned off in the BD SPA control settings.

Figure 1 - Side View

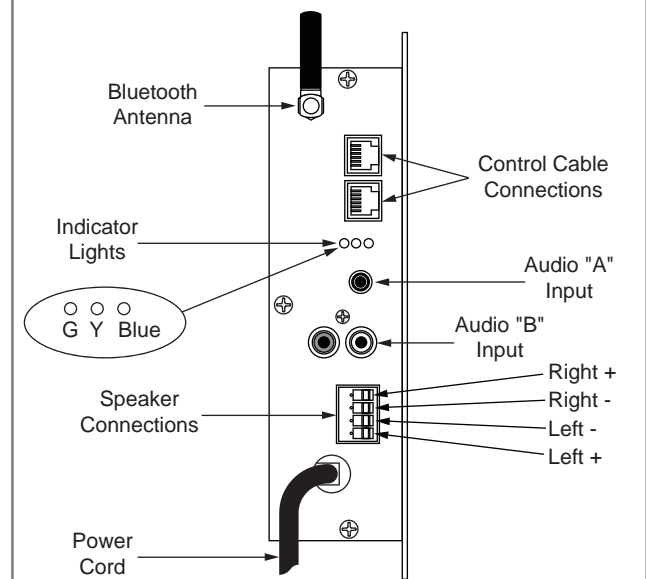

Figure 2 - Top View

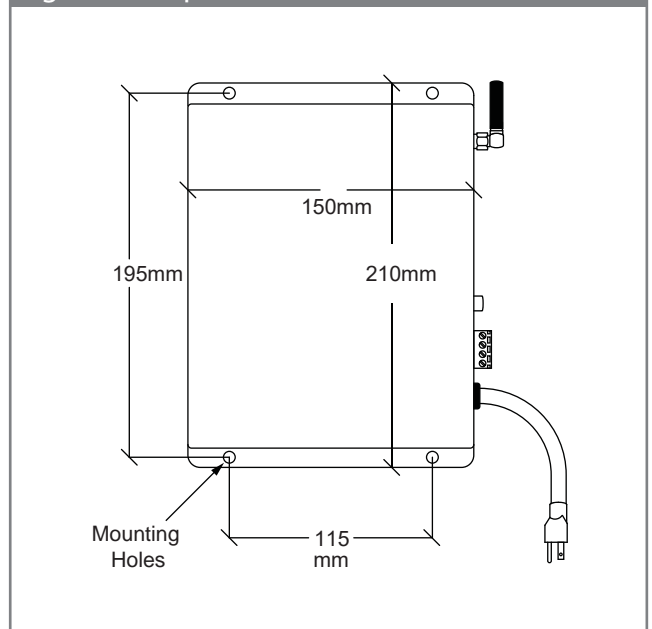
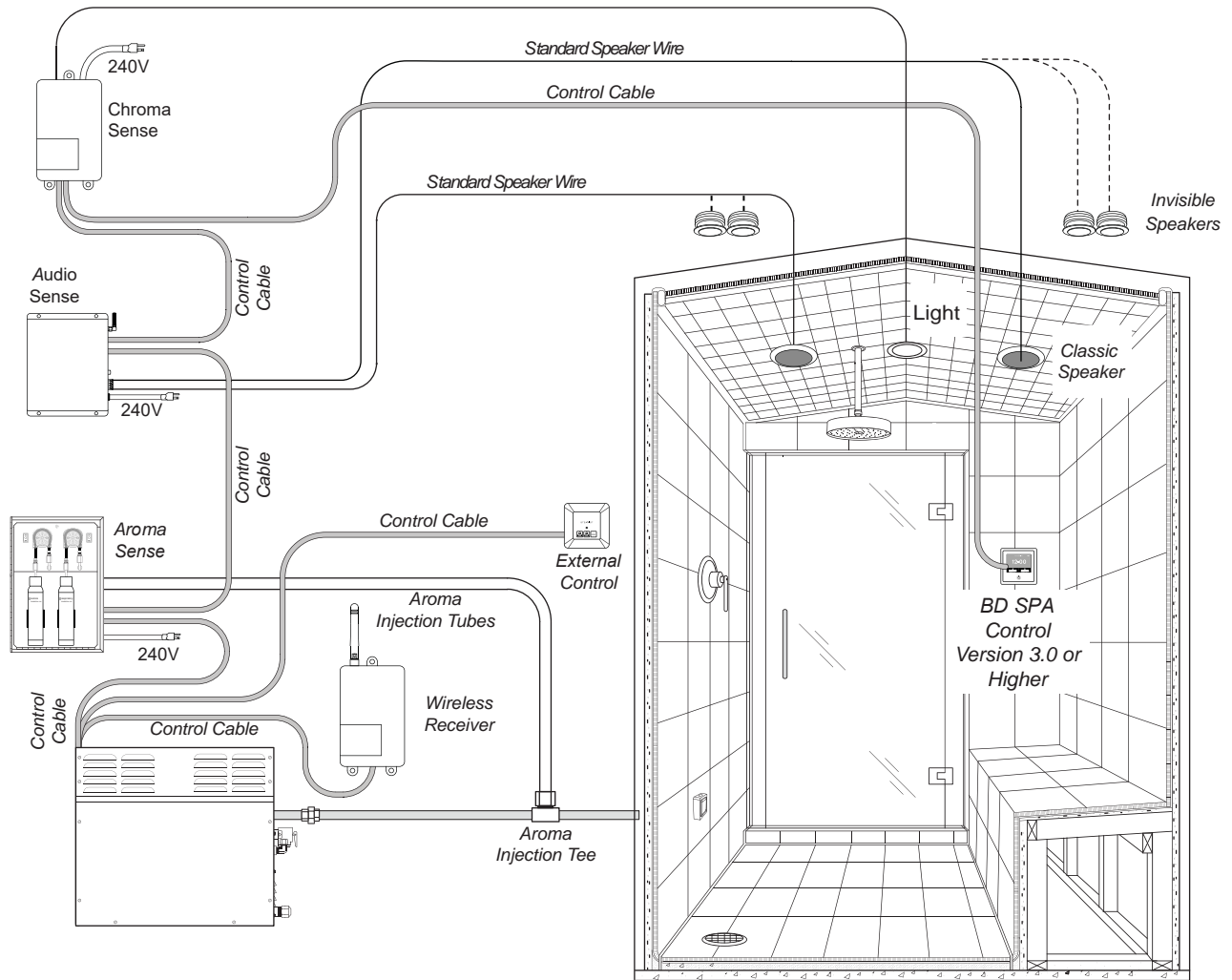

Figure 3



Shown with other Spa Options

**Specifications:**

Voltage: 240V 50/60 hz

Wattage: 70 Watts Max

Speakers: 4-8 Ohms

Audio Inputs: Bluetooth, Music A (3.5mm Jack), Music B (RCA Jacks)