

# BAGNODESIGN

EXPERTLY CRAFTED BATHROOMS

---

## Installation Guide

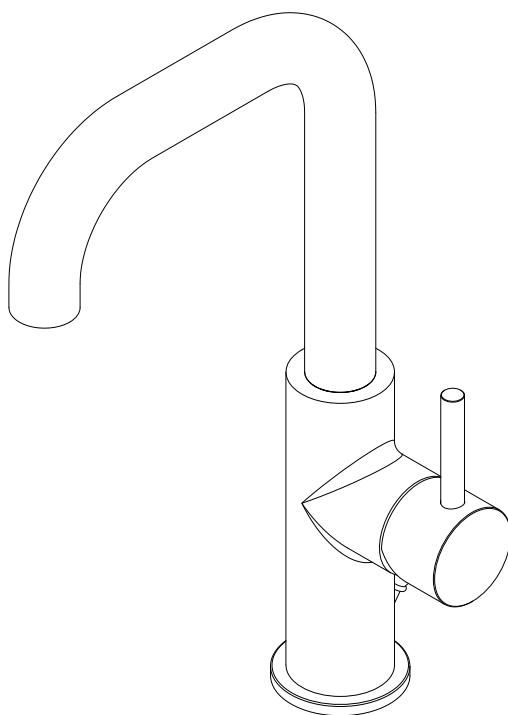

**BDM-MLI-322-XX**

M-LINE MONO TALL BASIN MIXER WITH SIDE LEVER

A member of **SANIPEXGROUP**  
[www.sanipexgroup.com](http://www.sanipexgroup.com)



## IMPORTANT PLEASE READ

All products manufactured and supplied by BAGNODESIGN are fit for purpose as long as they are Installed, used correctly, cleaned and receive regular maintenance in accordance with these instructions...

Remove all packaging and check the product for damage or missing parts before commencing with the installation.

Any alterations made to this product and its components may infringe product certification, infringe water regulations and invalidate the guarantee.

The Installation must comply with all local/national water supply authority regulations/byelaws and building and plumbing regulations, therefore we strongly recommend that your product be installed by a reputable qualified trade's person.

## PRODUCT LIFECYCLE

*"The product lifecycle is the collective stages that a product goes through from its conception and design through to its ultimate disposal."*

## DISPOSAL GUIDANCE

The best way to ensure your Product has a long life is to follow the Care and Maintenance guides set by the Manufacture after purchase. This document can be found at [www.bagnodesignlondon.com](http://www.bagnodesignlondon.com)

The lifecycle of the product is not in correlation to the product Guarantee; the standards the products are manufactured or certified to (e.g. CE & WRAS) can exceed past the Guarantee duration.

After the lifecycle of the product is deemed complete by the end-user please follow the below to dispose of the items correctly...

### **Mixers (Taps):**

If the mixers are no longer accepted due to mechanical use or aesthetic style, these can be disposed of at a registered Local Authority waste recycling centre where the individual components can be sorted.

## CLEANING CARE GUIDE

Please follow the below recommendations to ensure the product performs to your satisfaction and gives many years of use:

We recommend cleaning with a soft damp cloth and mild soap solution.

Do not use cream cleaners, cleaners containing bleach or abrasive cleaning agents

Do not scrub or scour.

Do not use solvent based cleaners.

Some nickel finishes will very slightly darken over time.

Specific stainless steel cleaners can be used on stainless steel products.

## GENERAL INSTALLATION:

To the installer, please read and follow these instructions carefully, as the guarantee is only valid if the product is installed as directed.

Don't rush, read the instructions first and run through them before you begin, keep the fittings together to avoid loss, do not overtighten screws or bolts.

If the product is covered with polythene protective film, do not remove until the installation is complete to grant maximum protection. However, remove film where any two surfaces will be in permanent contact. If tools are required to be used on a 'finished' surface, please place a cloth or similar over the area to protect the item from unnecessary scratching.

Before making any inlet pipe connections, all supply pipes **MUST** be flushed to remove debris such as solder, swarf, plastics and other building/construction substances.

The fitting of an in-line filter is recommended, failure to do this could result in damage to the cartridge and its components, it could also result in poor performance water flow from the outlet.

The fitting of isolation/stop valves on the inlet feeds is advised for ease of maintenance.

On fittings such as faceplates a small amount of lubrication is recommended on the rubber seals for ease of fitting.

## CONNECTIONS:

Flexible inlet pipes must be connected carefully to the plumbing system so that they do not **bend, twist or kink**. Failure to do so can result in poor performance from the mixer and possible failure of the hose leading to bursting and leakage.

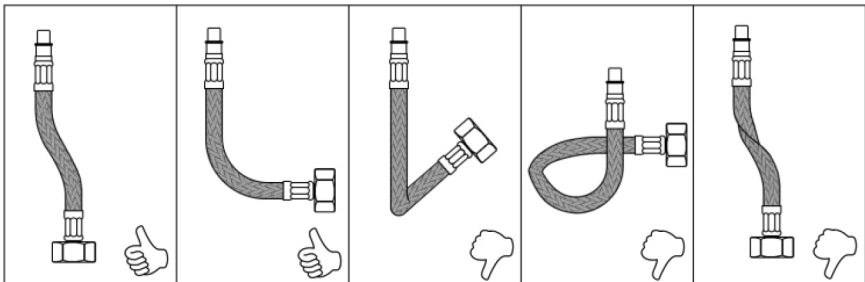

Pipework to concealed mixers must be installed in accordance to local regulations and is recommended to be insulated to prevent heat loss, prevent freezing and reduce condensation.

Hot and cold operating pressures should be kept as balanced as possible in order to maintain maximum efficiency.

## MONO BASIN MIXER W/PUW

### MONO BIDET MIXER W/PUW CONT...

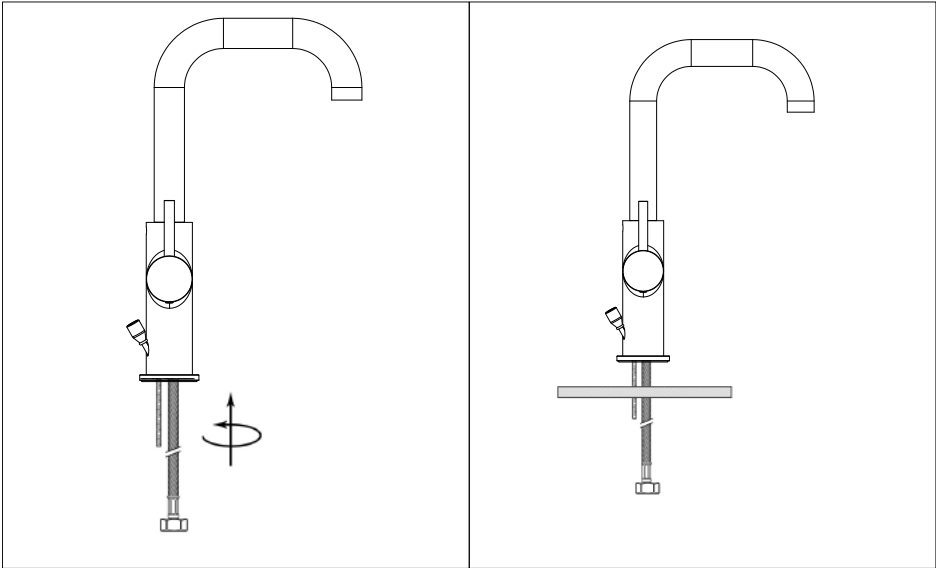

Install the threaded rods and hand-tighten the flex-pipes into the bottom of the mixer body.

Feed the assembly through the hole in the basin/countertop.

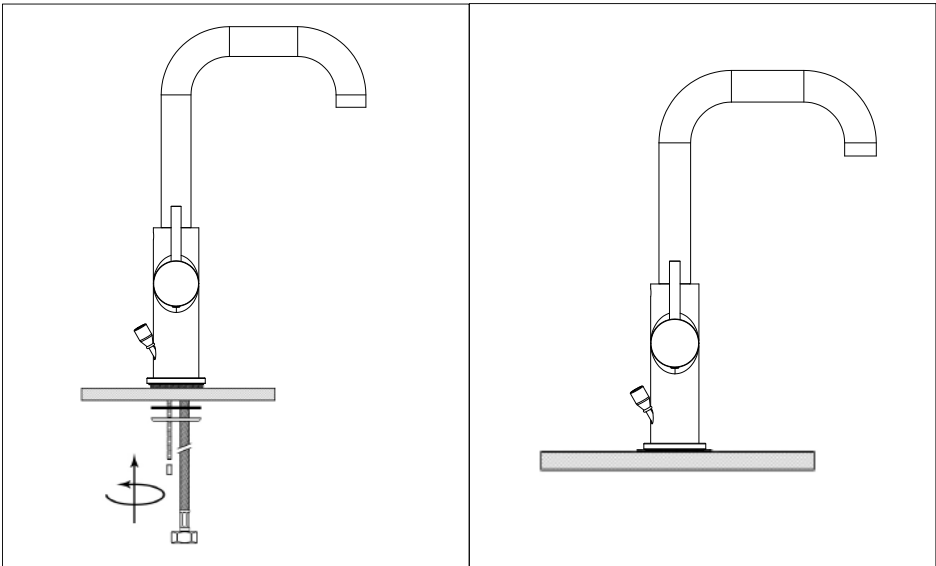

Slide the rubber 'C' washer followed by the metal 'C' washer and tighten the back nuts with a spanner to secure the mixer.

Flush the pipework, then connect the flexi-pipes to the isolation valves, turn on the water, run the tap and check for leaks.

## POP-UP WASTE ASSEMBLY (PUW)

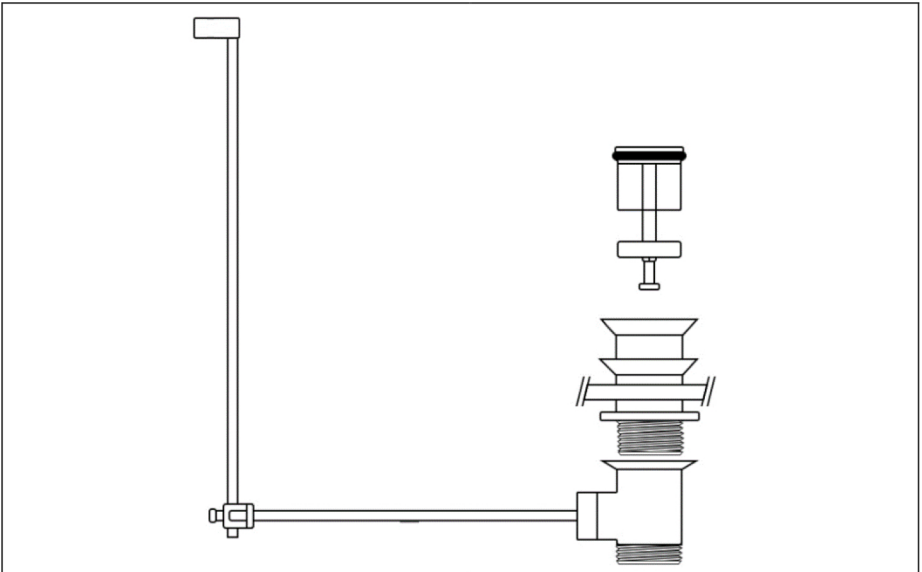

Disassemble the pop-up waste and reassemble onto the basin ensuring the foam washer is placed between the top waste housing and the basin. The rubber washer is to be placed on the bottom waste housing before being tightened

Insert the vertical pop up rod into the mixer body and connect to the horizontal rod on the waste body using the connector provided. Slide down push rod into rod link then push both rods down to the furthest point and tighten.

Adjust the plunger by screwing in/out to suit the depth required, secure with the back-nut.



# BAGNODESIGN

EXPERTLY CRAFTED BATHROOMS

---

---

---

---

---

---

---

---

---

---

---

---

A member of SANIPEXGROUP  
[www.sanipexgroup.com](http://www.sanipexgroup.com)