

BAGNODESIGN

EXPERTLY CRAFTED BATHROOMS

Installation Guide

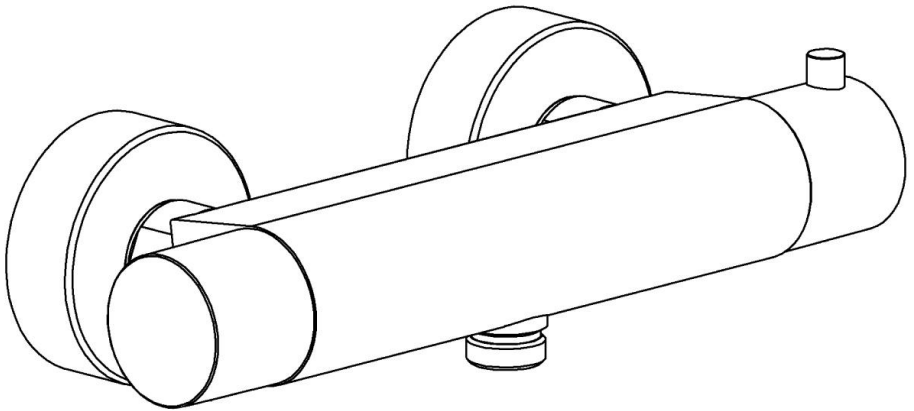

M-LINE

Thermostatic shower mixer bottom outlet

A member of  SANIPEXGROUP

Please leave these instructions with the customer

GENERAL CHARACTERISTICS

The Valve is suitable for all water heating systems provided it is installed correctly by a competent and qualified installer. Please refer to installation diagrams.

OPERATING SPECIFICATIONS

Hot water supply temperature:

Maximum: 85°C

Minimum: 5°C Higher than maximum required mixed temperature.

Advisable 65°C

Minimum difference between hot and mixed temperature is 10°C

Operating Pressure

Maximum: 5 Bar

Minimum: 0.1 Bar

Hot and Cold Operating pressure should be kept as balanced as possible in order to maintain maximum efficiency.

When the supply pressure is higher than a 5 Bar a pressure reducing valve should be fitted before the shower valve.

TECHNICAL DATA

The mixer ports are supplied ¾" BSP threads.

The mixer is provided with an outlet at base of the mixer ½ BSP thread.

PLUMBING RECOMMENDATIONS

- ◆ An independent hot and cold water supply is required for the shower system please refer to installation diagrams.
- ◆ Large runs of pipe work will cause frictional loss of pressure.
- ◆ The recommended pipe work from both cylinder and water tank should be 22mm minimum for low-pressure systems.
- ◆ If more than one shower valve is installed the minimum feed from tank and cylinder should be 28mm. (Ensure adequate supply of both hot and cold water can be maintained).

WATER BYE LAWS

The mixing valve should be installed in accordance with the water bye laws. For further details refer to the latest copy of Water Bye Laws guide or your local water authority.

INSTALLATION

IMPORTANT: Rinse pipe work carefully prior to fitting the mixer.

- ◆ Install mixer with the water outlet facing downwards and the temperature control to the right. The centre between the water inlets is 150mm.

- ◆ The hot water supply connects to the left hand marked with a red dot.
The flexible shower hose fits the outlet at the bottom of the mixer.
- ◆ Place sealing washers inside mixer nuts. Screw unions into mixer nuts and tighten with 30mm spanner.
- ◆ Turn on water supply and check for leaks.

TEMPERATURE SETTING

The mixer has been set in the factory under balanced pressures at 38°C. Where conditions are different from the above the temperature of the mixed water may vary from setting. You can adjust the calibration of the mixer to suit individual requirements.

FOLLOW THESE INSTRUCTIONS CAREFULLY

- ◆ The valve is set at 38°C. Check this is the case by using a thermometer in the water flow from the valve.
- ◆ If you require a hotter flow, re-set the calibration.
- ◆ Remove the cap(1) from temperature control. Remove grub screw(2) with 2,5mm Alan key. The knob (3) can now be pulled off.
- ◆ Turn the spindle (A) until the temperature is at the required level. Test again using a thermometer.
- ◆ When water temperature is at the required level re-fit handle(3), grub screw(2) and cap(1).

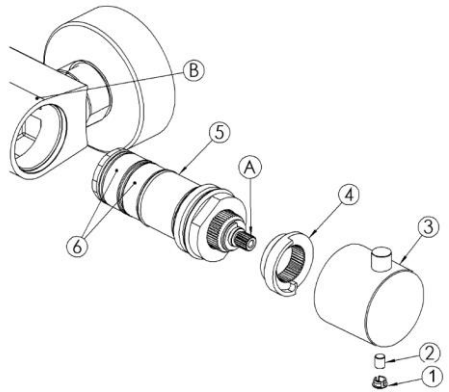

CARTRIDGE CHANGE AND CLEANING

- Remove the cap(1) from temperature control, remove grub screw (2) with 2,5 mm Alan key, take off temperature control (3) and plastic stop ring(4).
- Unscrew cartridge(5) using 30 mm spanner. Wash filters(6) under running water or leave to soak in vinegar or de-scaling agent.
- Before re-assembling cartridge clean its housing with wet cloth and grease “O” rings on cartridge.
- Re-assembling cartridge into body.
- Re-fit plastic stop ring(4) according to the drawing and turn spindle(A) until you reach required temperature 38°C.
- Re-fit temperature control knob (3). Test that maximum temperature is set at 43°C.
- Re-fit grub screws (2) and cap(1).

CLEANING FILTERS

Through years of use impurities and lime scale could restrict flow of water through the filters of the cartridge. To clean the filter shut off water supply to both inlets. Unscrew mixer and clean filters.

IMPORTANT – CARE OF YOUR PRODUCT CLEANING

After use all finishes should be maintained by wiping with a soft, damp, clean cloth and then polished using a dry duster. NO abrasive powder, detergents or polishes should be used. Cleaner containing alcohol, acid or corrosive chemicals should not be used.

NOTE

- ◆ Some household bleaches and denture cleaners can damage plated or coloured finishes and if splashed onto a fitting should be immediately washed off with cold water.
- ◆ If these instructions are followed we believe this fitting will give many years of satisfactory use.
- ◆ We have a policy of continuous improvement and reserve the right to change specification without notice.
- ◆ In case of prolonged disuse of the mixer in winter time, it is recommended to close the system and empty the mixer to avoid damages caused by frost.

Oakwell Way, Birstall
Leeds, England WF9 17LU

A member of  SANIPEXGROUP