

BAGNODESIGN

EXPERTLY CRAFTED BATHROOMS

Installation Guide

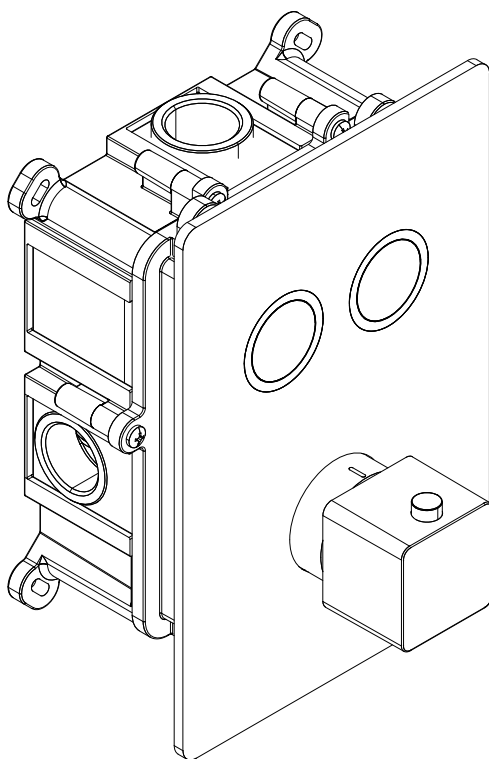

BDM-TOK-T302SS-XX

TOKO SQUARE 20 THERMOSTATIC SHOWER MIXER

A member of **SANIPEXGROUP**
www.sanipexgroup.com

IMPORTANT PLEASE READ

All products manufactured and supplied by BAGNODESIGN are fit for purpose as long as they are Installed, used correctly, cleaned and receive regular maintenance in accordance with these instructions...

Remove all packaging and check the product for damage or missing parts before commencing with the installation.

Any alterations made to this product and its components may infringe product certification, infringe water regulations and invalidate the guarantee. The Installation must comply with all local/national water supply authority regulations/bylaws and building and plumbing regulations, therefore we strongly recommend that your product be installed by a reputable qualified trade's person.

PRODUCT LIFECYCLE

"The product LiveCyclele is the collective stages that a product goes through from its conception and design through to its ultimate disposal."

DISPOSAL GUIDANCE

The best way to ensure your Product has a long life is to follow the Care and Maintenance guides set by the Manufacture after purchase. This document can be found at www.sanipexgroup.com. The life cycle of the product is not in correlation to the product Guarantee; the standards the products are manufactured or certified to (e.g. CE & WRAS) can exceed past the Guarantee duration. After the life cycle of the product is deemed complete by the end-user please follow the below to dispose of the items correctly...

Mixers (Taps):

If the mixers are no longer accepted due to mechanical use or aesthetic style, these can be disposed of at a registered Local Authority waste recycling center where the individual components can be sorted.

CLEANING CARE GUIDE

Only use a mild soap and water for cleaning.
Rinse with water to remove the mild soap solution.
We recommend the product is dried using a soft cloth after every use.

Never use any abrasive or strong cleaning products containing, bleaches, acids (hydrochloric, formic, phosphorus, chlorine or acetic), strong detergents, limescale remover, alcohol or dyes etc.
Never use abrasive cleaning pads, wire wool or microfibre cloths.
Never use cleaning equipment that may have been pre-used and contaminated with the above substances.
Never apply the cleaning product directly onto the finished surface.

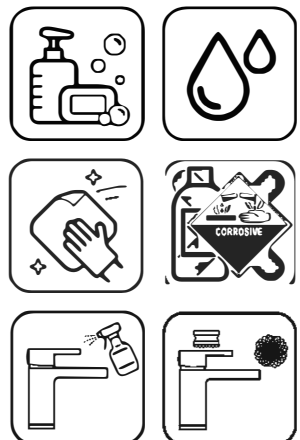

GENERAL FEATURES:

This mixer is suitable for all water heating systems provided it is installed correctly by a competent and qualified installer.

OPERATING SPECIFICATIONS:

Hot water supply temperature:

Maximum: 85°C

Advisable: 65°C

Minimum: 5°C

Minimum difference between hot and mixed temperature 10°C

The temperature of the inlet hot water must be higher than the maximum mixed water temperature required from the outlet.

Working Pressures

Maximum: 10 bar

Minimum: 1 bar

Hot and cold operating pressures should be kept as balanced as possible in order to maintain maximum efficiency.

When the supply pressure is higher than 5 bar a pressure reducing valve should be fitted before the shower mixer.

Technical Data

The mixer is supplied with a cover plate for the installation at a depth from 72 mm to 91.5 mm. The temperature control knob is pre-set from the manufacturer at 38°C.

The mixer ports are supplied with a female thread G ½", G ¾", NPT ½", NPT ¾".

The thermostatic mixer is provided with an additional outlet at the base of the mixer. When using the bottom outlet a flow control is required between the mixer and the outlet.

The bottom outlet is sealed with a removable plug.

Plumbing recommendations

- An independent hot and cold water supply is required for the shower system.
- The recommended pipe work should be 22mm minimum for low pressure system.
- If more than one shower mixer is installed, the minimum feed should be 28mm. (ensure adequate supply of both hot and cold water can be maintained)
- READ CAREFULLY THIS MANUAL BEFORE USING YOUR MIXER AND KEEP IT AT HAND FOR FUTURE REQUIREMENTS

INSTALLATION:

Consider the thickness of the final coating (tiles, marble etc.)

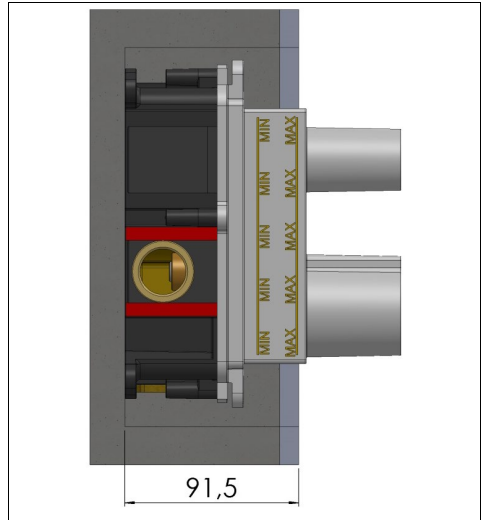
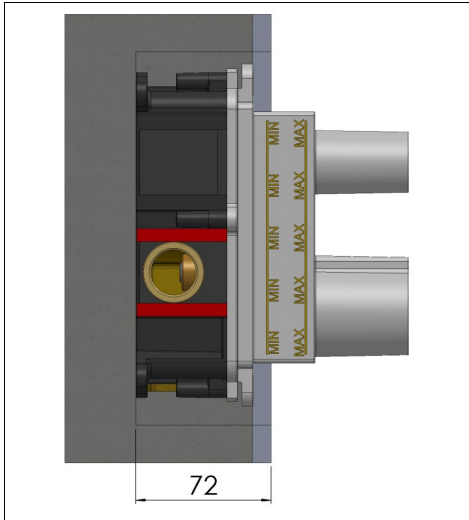

Keep a 135x100 mm hole in the wall to cut the protection and for the future maintenance of the product.

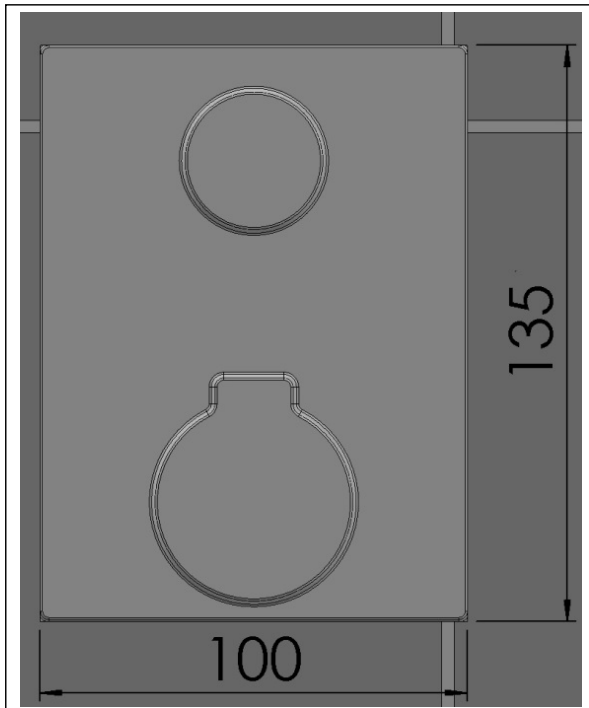

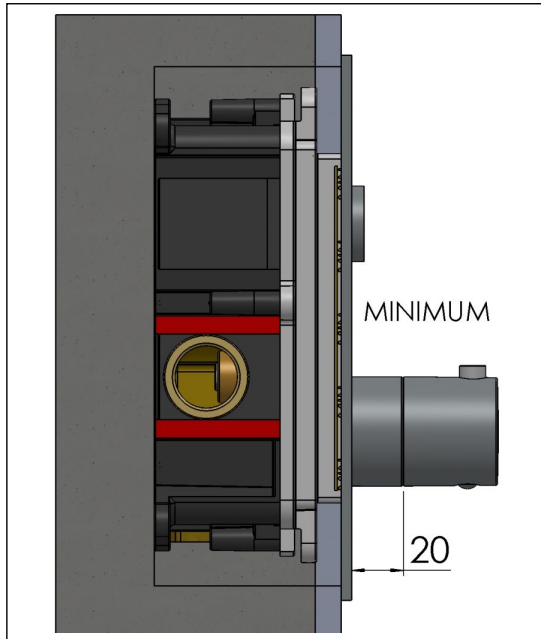

The plate slides from a minimum of 20 mm to a maximum of 1mm.

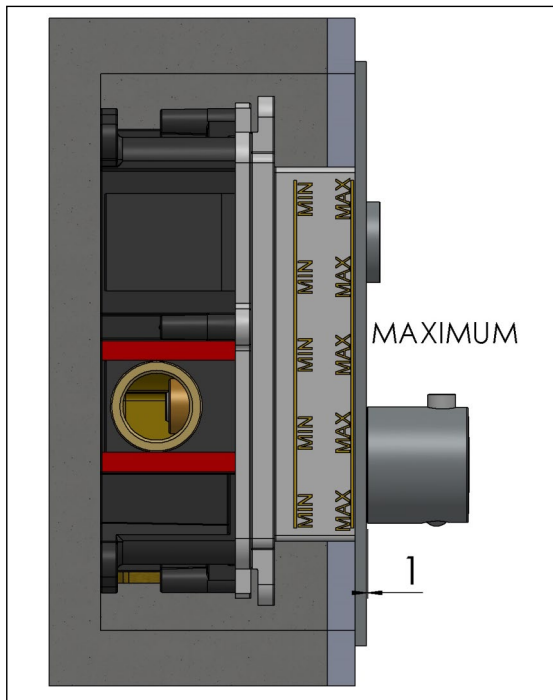

Before fixing the box, screw into the mixer ports the correct fittings for the type of tube chosen for your hydraulic system.
ATTENTION Fittings not supplied.

Use a level to find the correct position

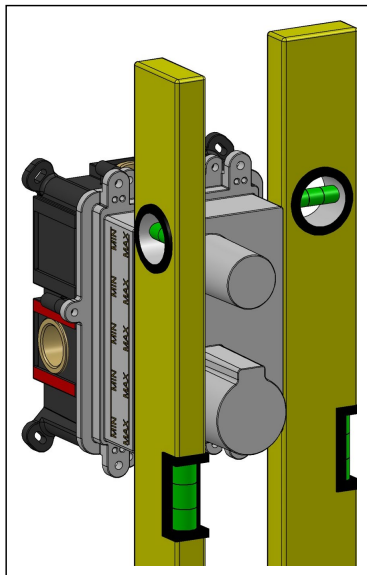

For the in-wall installation, drill the wall and use the plugs and screws to fix the box to the wall

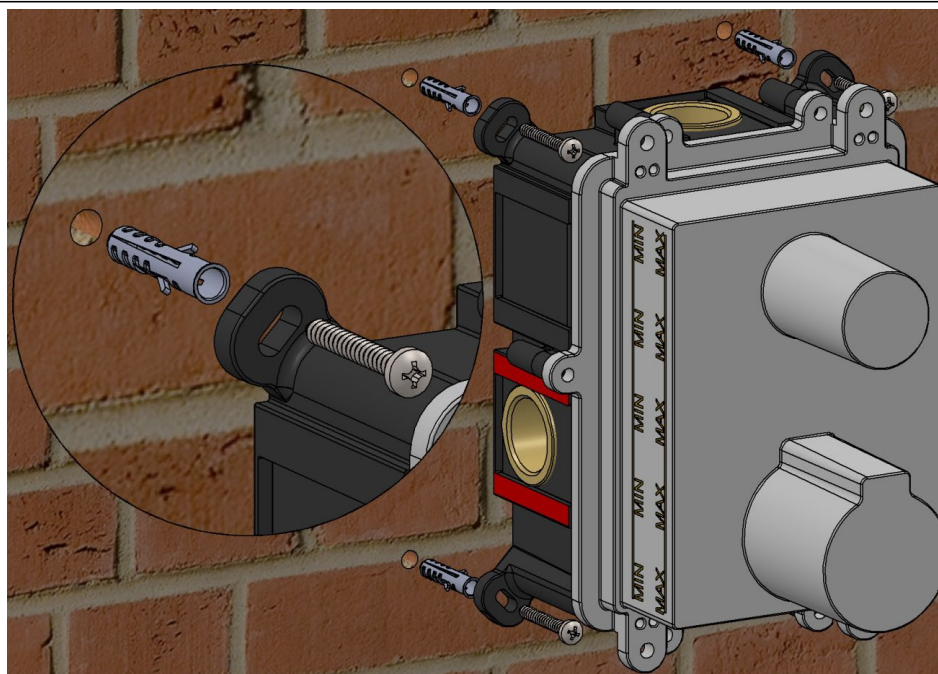

For the frame installation use the screws to fix the box to the woods

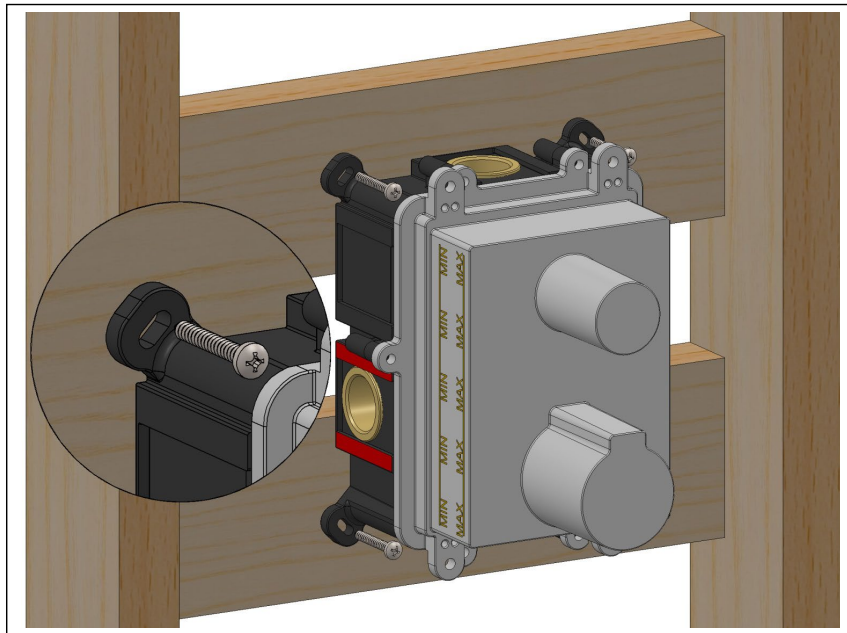

For the rear installation use the screw to fix the box to the drywall

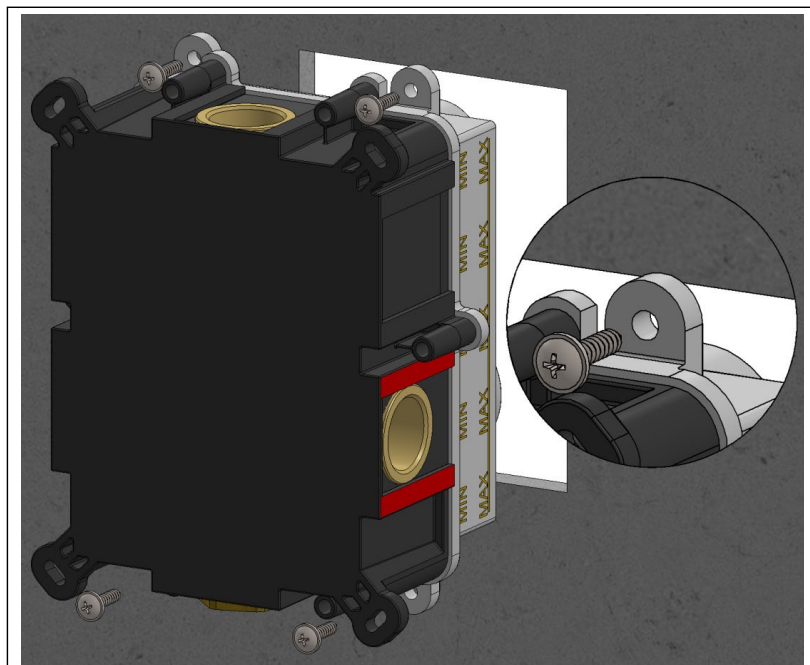

The box is made of plastic material

ATTENTION Never expose box to open flame or excessive heat.

In case of mixer ports NPT threaded, use fittings with a minimum length of 3".

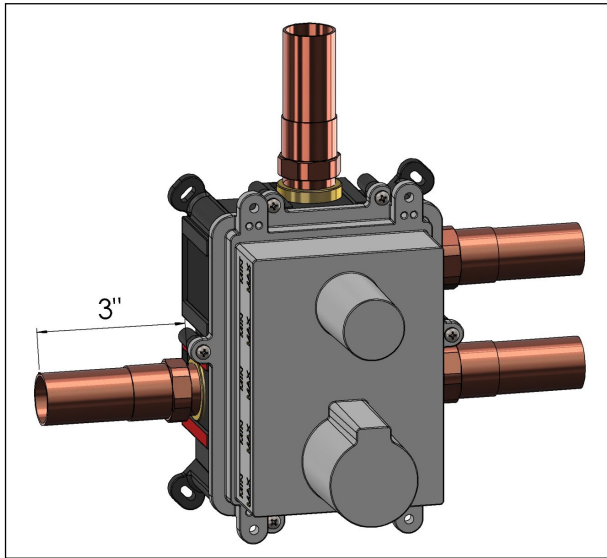

Installation scheme

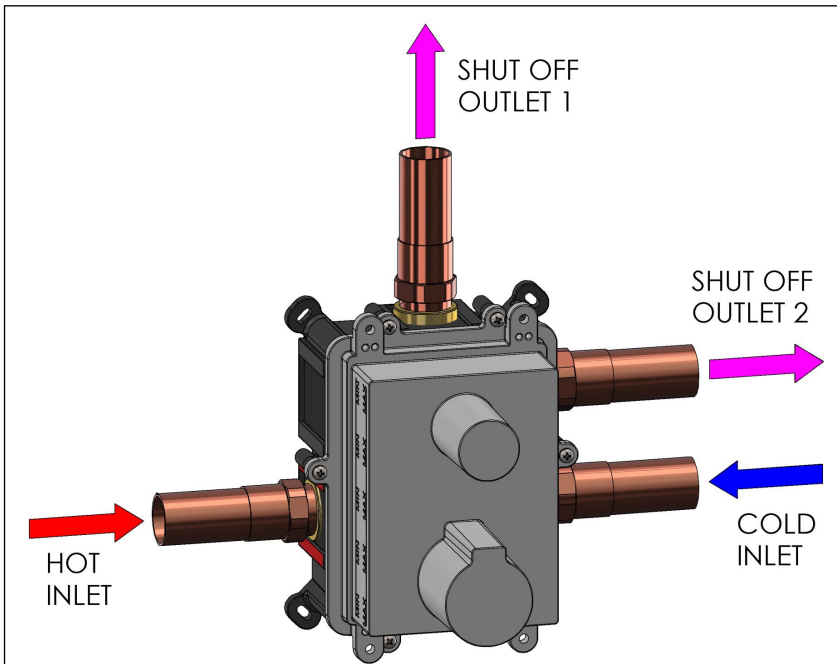

Before tiling attach the seal to the wall with glue.

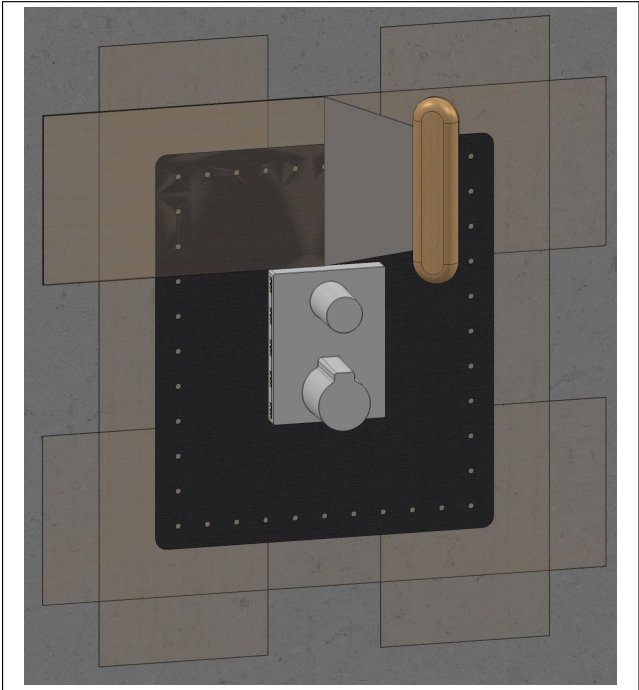

TRIM FIXING

Once the mixer is installed in the wall, cut along the finished wall and remove the plastic guard.

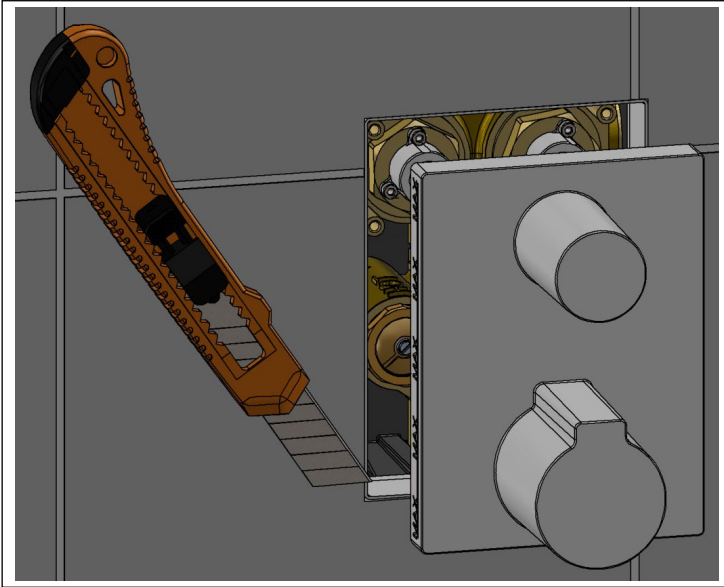

Screw the two white nylon grub screws. Place the plate support. Use the template to find the correct position.

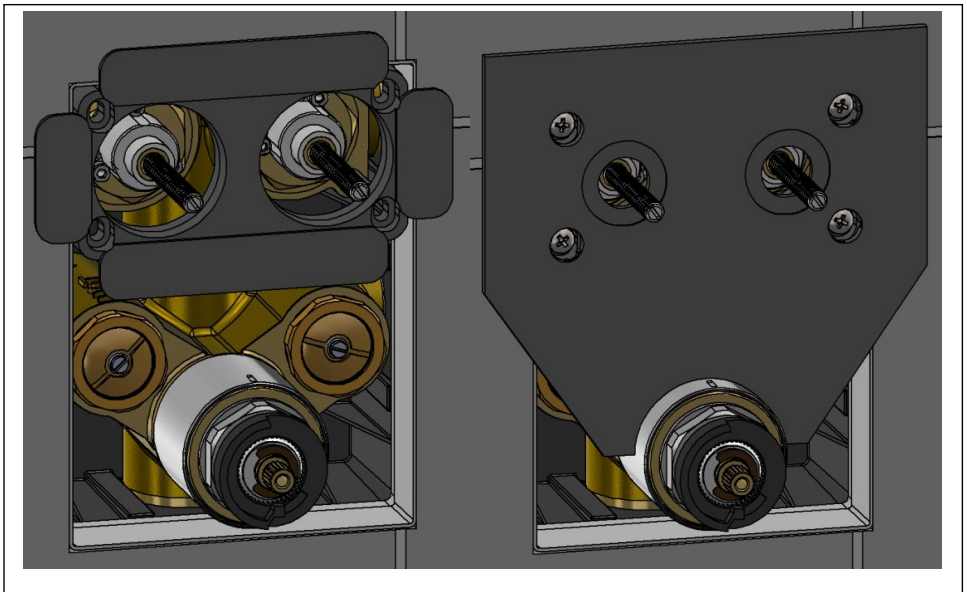

Screw the four screws for fix the plate support. Provided two different type of screws; four long 20 mm and four long 30 mm. Try first with screws long 20, if they are not screwed, use the screw long 30 mm.

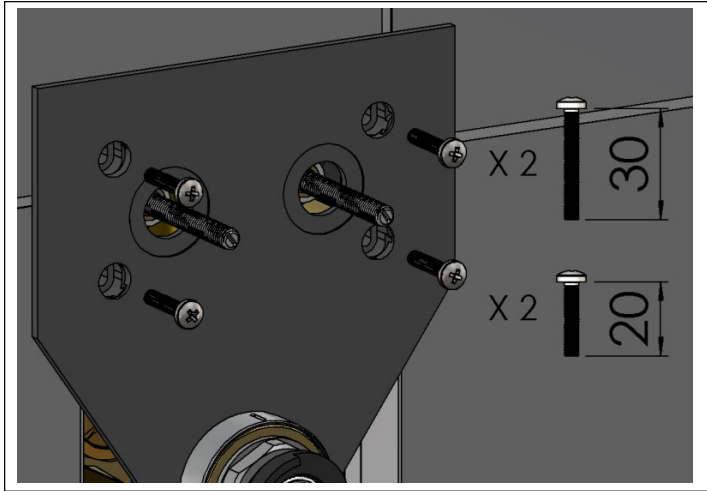

The mixer is provided in the **ON** position. Press the plastic threaded rod and check that it is in the **ON** position.

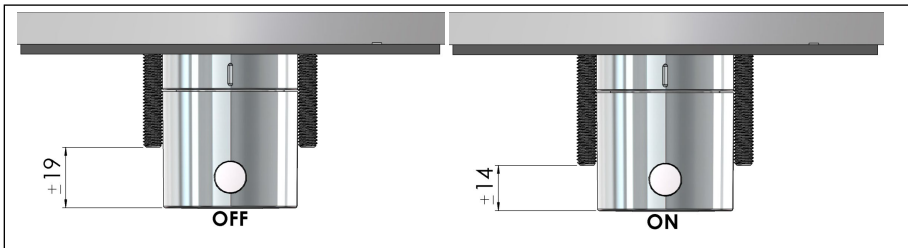

Screw the retainer (1), on the plastic threaded rod (2) until the template (3). Screw the grub screw (4) with the 2mm Allen key (5).

Repeat on both ON/OFF systems

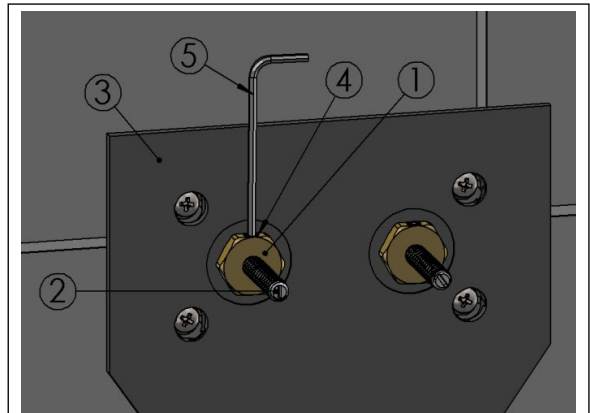

Unscrew the plastic threaded rod (2) and the retainer (1). Remove the template (3). Cut the plastic threaded rod near the retainer. Remove the cutting burr.

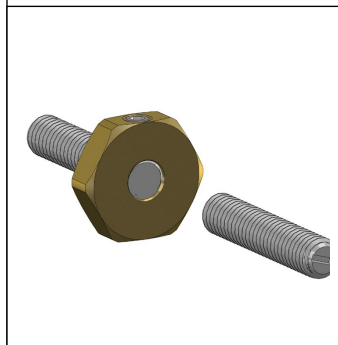
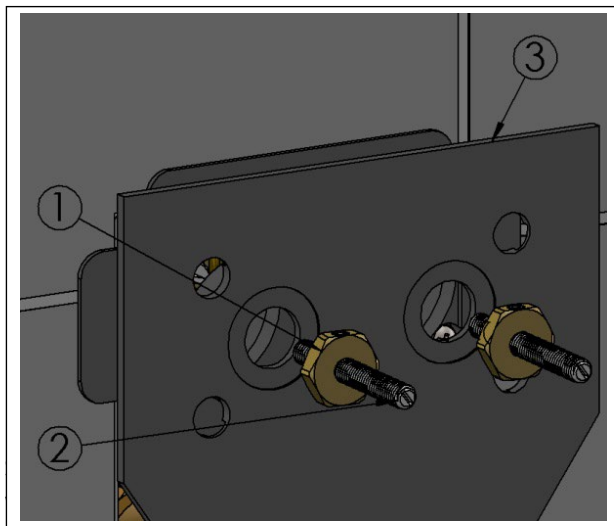

Screw the plastic threaded rod with retainer in its place

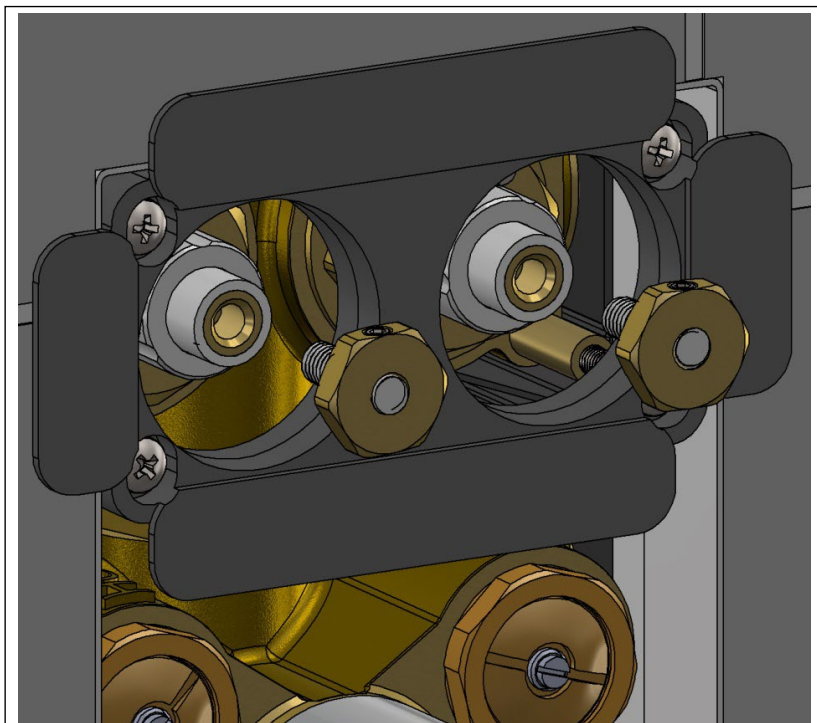

Put the silicone between the plastic guard and the wall and over the plate support.

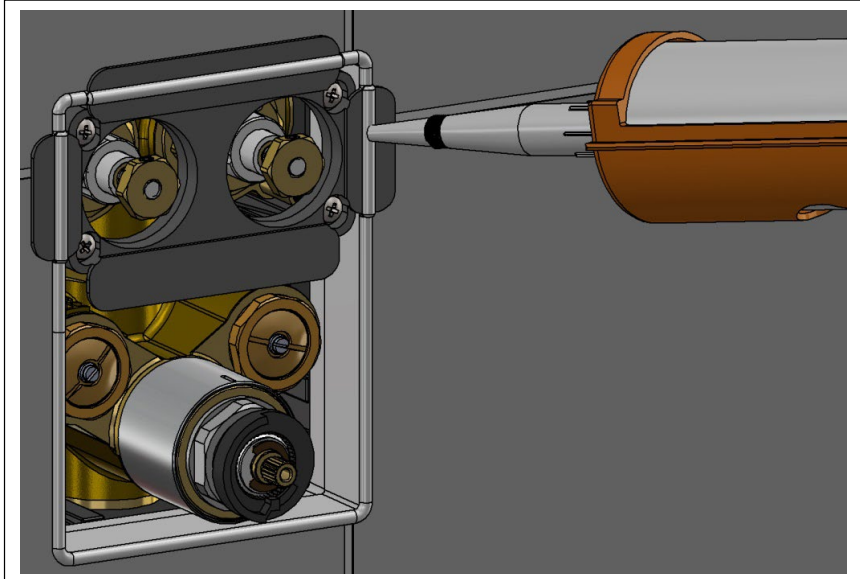

Insert the cover plate (1) on the body valve(2). Push the cover plate (1) to the wall. Place the handle (3), screw the grub screw (4) with an 2,5 mm Allen key, place the cup (5).

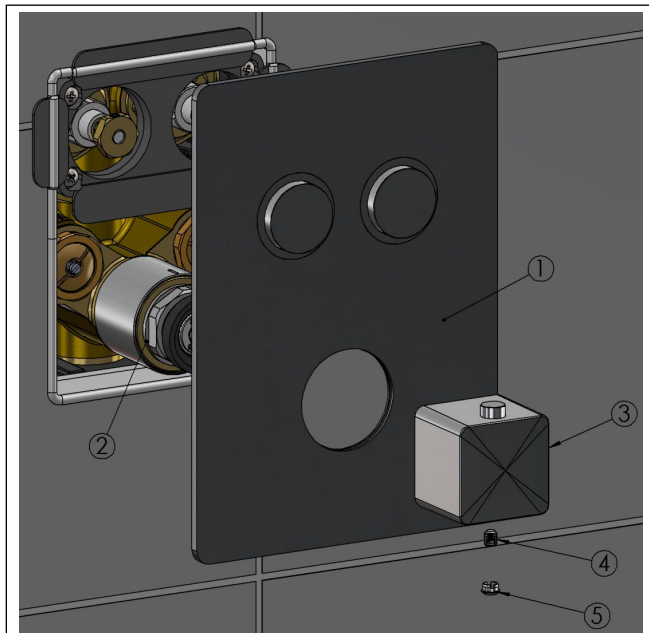

Check the correct operation of the closure system

ON POSITION



OFF POSITION



MAINTENANCE REPLACEMENT OF THE THERMOSTATIC CARTRIDGE AND VALVE HOLDER

THERMOSTATIC CARTRIDGE

- 1) Remove the cup(1), Unscrew the grub screw (2) with an 2,5 mm Allen key
- 2) Remove the handle (3). Remove the plate (4).
- 3) Close the water inlets. With closures on the valve holders (7), screw for 7 turns the front screws with a flat screwdriver, in order to isolate the thermostatic cartridge.
- 4) Remove the stop ring(5).
- 5) Unscrew the thermostatic cartridge(6) anti-clockwise with a 30mm wrench.
- 6) Remove the thermostatic cartridge(6) and clean its filters under running water or leave to soak in vinegar in presence of limestone. **Grease the O-rings and, if damaged, replace them with new ones. 2x OR 2100 mm 25,12 x 1,78 1x OR 2106 mm 26,7 x 1,78**

VALVE HOLDER

- 1) Close the water inlets
- 2) Unscrew the valve holders (7) anti-clockwise with a 27mm wrench. **DO NOT USE A SCREW DRIVER**
- 3) Remove the valve holders and clean the filters under running water or leave them soak in presence of limestone
- 4) **Exerting a max torque of 8-10 Nm or 70-80 lbf.in for replacement**

POSITION OF THE STOP RING

- 1) Place the stop ring(5) as shown in the image below.
- 2) Using the handle, rotate the broached rod (A) to reach the set temperature of 38°C (check the temperature with a thermometer).
- 3) **Turn clockwise for cold or anti-clockwise for hot water.**

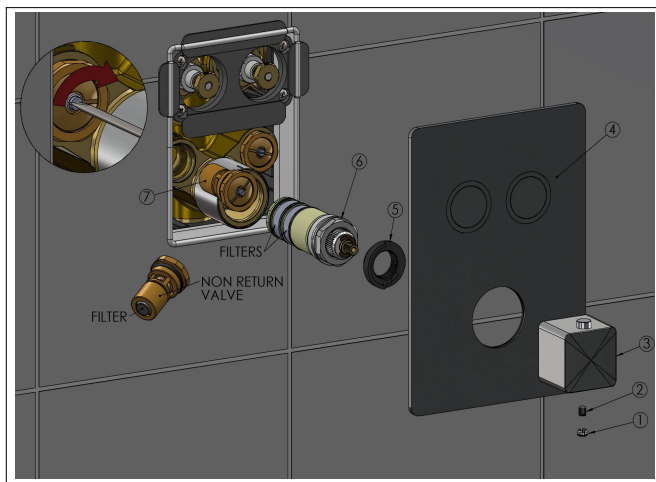

MAINTENANCE-REPLACEMENT OF THE SHUT OFF

- 1) Close the water inlets.
- 2) Remove the cup(1), unscrew the grub screw (2) with an 2,5 mm Allen key
- 3) Remove the handle (3).
- 4) Remove the cover plate (4)
- 5) Unscrew the ON/OFF cartridge(5) anti-clockwise with a 30mm wrench.
- 6) Remove the ON/OFF cartridge(5 and clean its filters under running water or leave to soak in vinegar in presence of limestone.

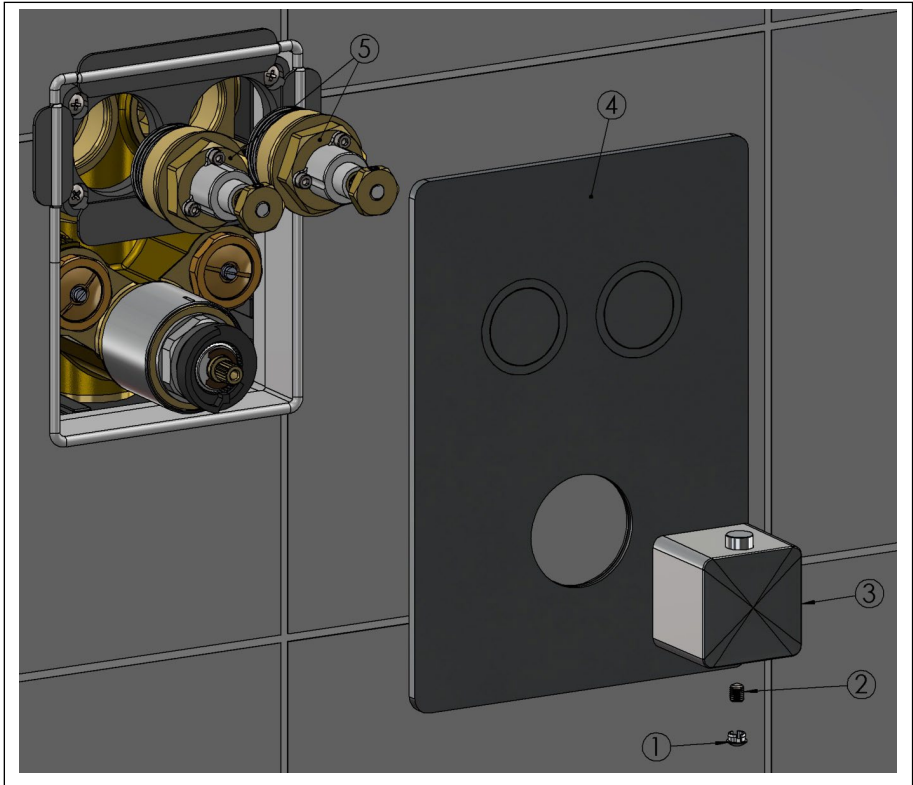

IMPORTANT-CLEANING OF THE MIXER

After use the mixer should be maintained by wiping with a soft, damp, clean cloth.

NO abrasive powders, detergents or polishes, cleaners containing alcohol, acid or corrosive chemicals should be used.

In case of prolonged disuse of the mixer in winter time, it is recommended to close the system and empty the mixer to avoid damages caused by frost.

NOTES

- If these simple instructions are followed this mixer will give many years of satisfactory use.
- The company has policy of continuous improvement and reserve the right to change specification without notice.

TROUBLE SHOOTING

<i>Problem</i>	<i>Cause</i>	<i>Solution</i>
1. Reduced or missing flow.	<ul style="list-style-type: none"> a) Closed water inlets. b) Blocked mixer. c) Blocked connecting pipes. d) Blocked hand shower. e) Water flow reduction when other shut off valves are in function. 	<ul style="list-style-type: none"> a) Control the check valves. b) Check if the inlet filters are cleaned. c) Check if the connecting pipes are cleaned. d) Clean or replace the hand shower. e) Control if the check valves are fully open. Reduce the water flow of all open outlets.
2. The mixer does not shut off.	<ul style="list-style-type: none"> a) The gaskets are dirty. b) The gaskets are damaged. 	<ul style="list-style-type: none"> a) Clean/replace the gaskets. b) Replace the headwork.
3. Water too cold.	<ul style="list-style-type: none"> a) There is no enough hot water flowing through the mixer. b) The boiler system does not give enough hot water. c) The hot water inlet is restricted. 	<ul style="list-style-type: none"> a) Set the regulation handle towards the hot water side. b) Increase the temperature of the water fed from the boiler. c) Check for any restriction on the pipeline.
4. Water too hot.	<ul style="list-style-type: none"> a) There is not enough cold water flowing through the mixer. b) The cold water inlet is restricted. 	<ul style="list-style-type: none"> a) Set the regulation handle towards the cold water side. b) Check for any restriction on the pipeline.
5. Temperature varies during use.	<ul style="list-style-type: none"> a) Temperature has decreased below the minimum required. 	<ul style="list-style-type: none"> a) Wait for the hot water to be restored.
6. Fluctuation of temperature of the mixer water.	<ul style="list-style-type: none"> a) Inverted connections. b) Inverted mixer. 	<ul style="list-style-type: none"> a) Use a "reverse" cartridge. b) Invert the mixer
7. Increasing of the temperature by turning clockwise. Decreasing of the temperature by turning anti-clockwise	<ul style="list-style-type: none"> a) Inverted connections. b) Inverted mixer. 	<ul style="list-style-type: none"> a) Use a "reverse" cartridge. b) Invert the mixer.

