

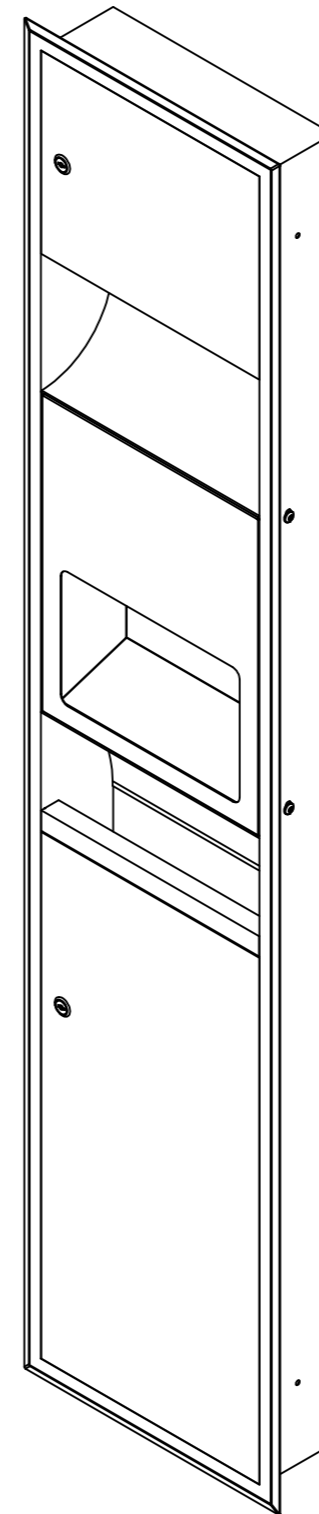

3 in 1 Unit

**Paper Towel Dispenser/
Hand Dryer/
Waste Receptacle**

BC25SCA



SPECIFICATION:

Cabinet, manufactured from 0.8mm (22 gauge), type-304 18/8 stainless steel with satin-finish.

Door, manufactured from 1.2mm (18 gauge), type-304 18/8 stainless steel with satin-finish, and tumbler locks keyed.

Hand dryer, Model No. EcoSlender

1.0kW, 230-240Vac.

Brush motor : 500W, 29000r.p.m. --50Hz/60Hz.

Designed with 95°C (203°F) thermostat.

Heater assembly : Designed with 85°C (185°F) thermostat.

Designed with 142°C (288°F) thermal cut-off.

Dryer shall deliver: 105 m³/h (62 CFM).--50Hz/60Hz.

Air speed : 82 m/s. --50Hz/60Hz.

Sound level : 77.6 ± 5 dB.

Approximately 10-15 seconds drying time.

Paper towel dispenser, capacity: 300-500 towels depending on the type and their folding.

Waste receptacle, capacity: 18L.

Dimension: 362x1660x104mm

Rough wall opening: 322x1620x110mm

Weight: 20.2kgs unpacked; 23.6kgs packed.

Dryer Wiring Instructions :

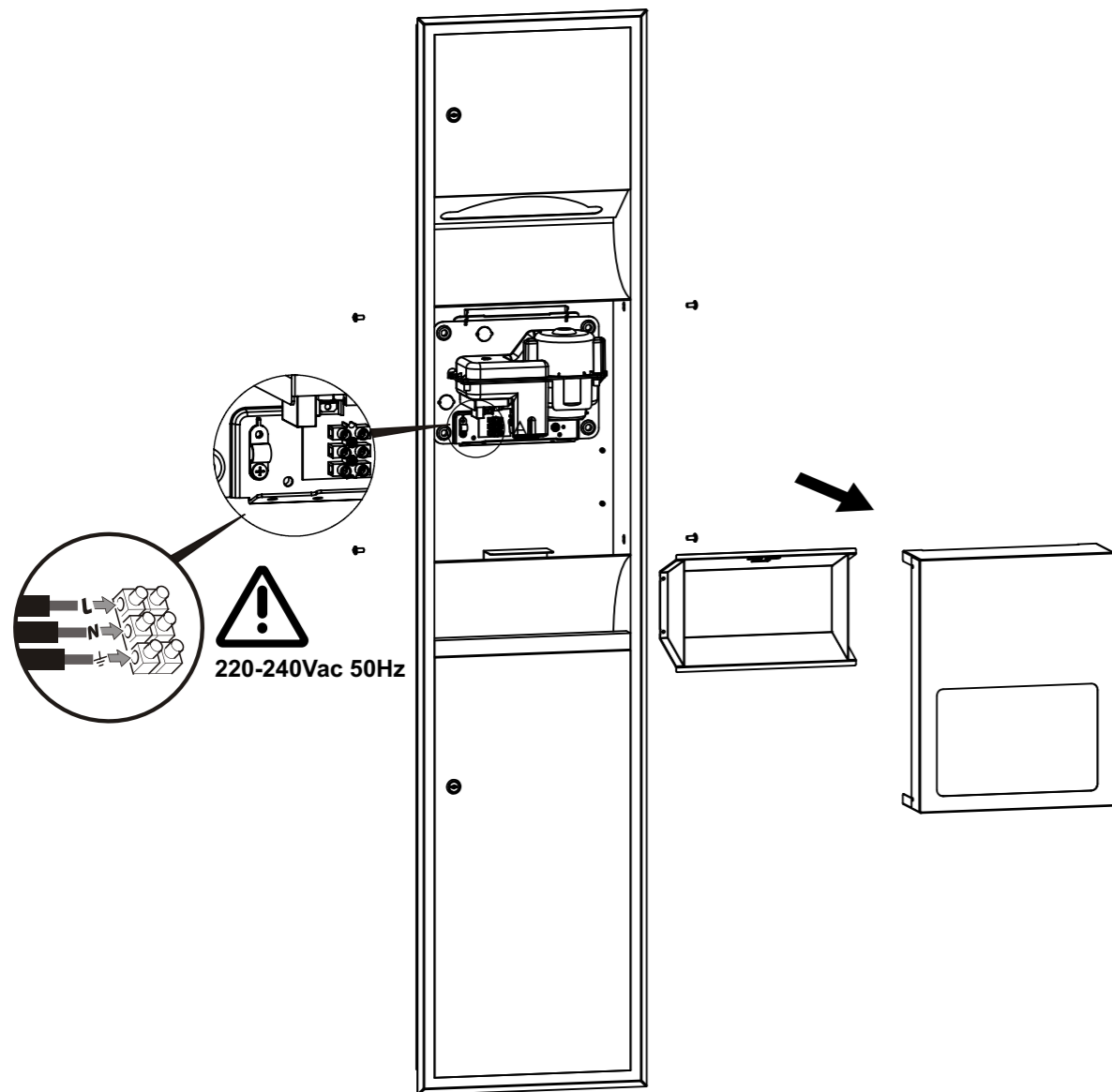

Connections:

- Remove the front cover and the drying chamber of hand dryer.
- Connect the live wire (colored red or black or brown) to the terminal block marked "L".
- Connect the neutral wire (colored white or blue) to the terminal block marked "N".
- Connect the ground wire (colored green or green and yellow) to the terminal block marked "⏚".
- Mount the drying chamber and front cover of hand dryer back and fixing the screws.

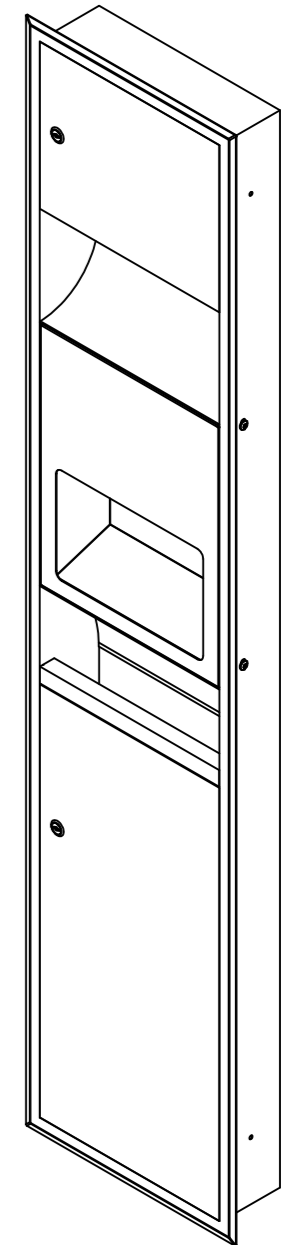
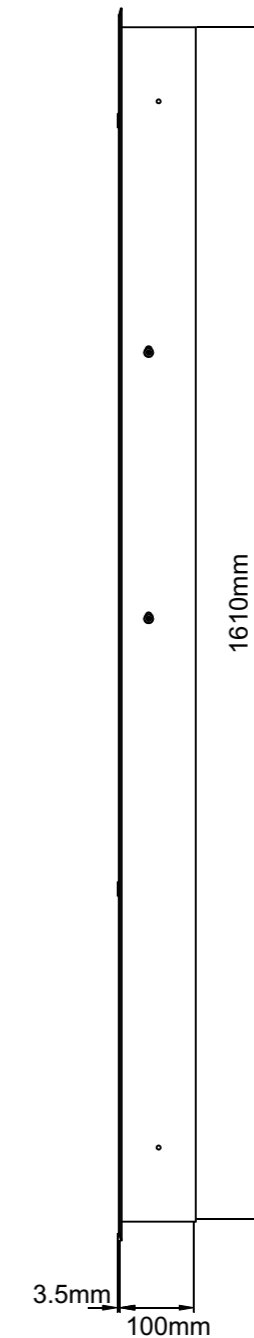
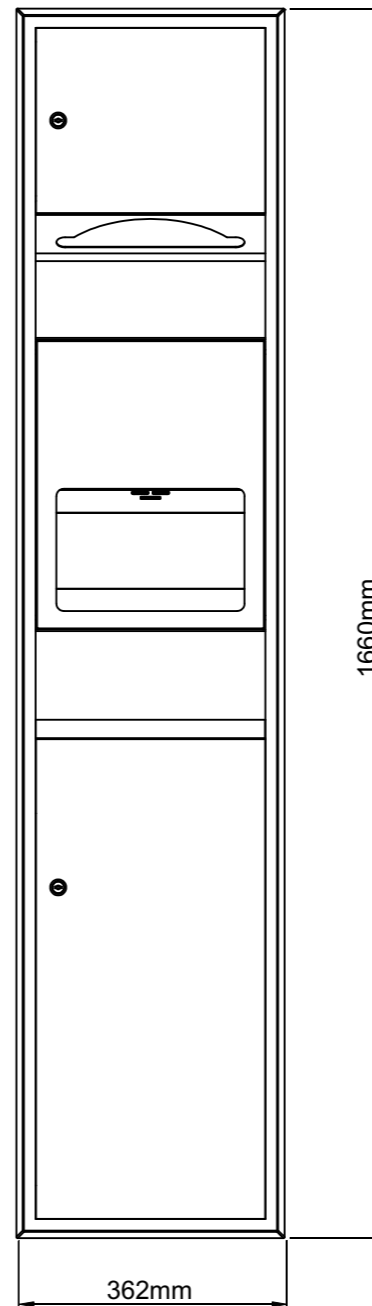
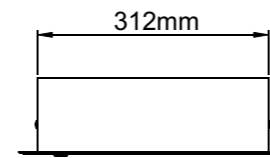

Important Information

This Product falls within the scope of the Waste Electrical & Electronic Equipment Directive 2012/19/EU. (WEEE)



NOTE: This Product should not be disposed of with household waste. Please recycle where facilities exist. Check with your local authority for recycling advice.