



CARMENTA
THE WELLNESS INDUSTRY

HAMMAM COLLECTIONS

ASSEMBLY INSTRUCTIONS



PRE-INSTALLATION

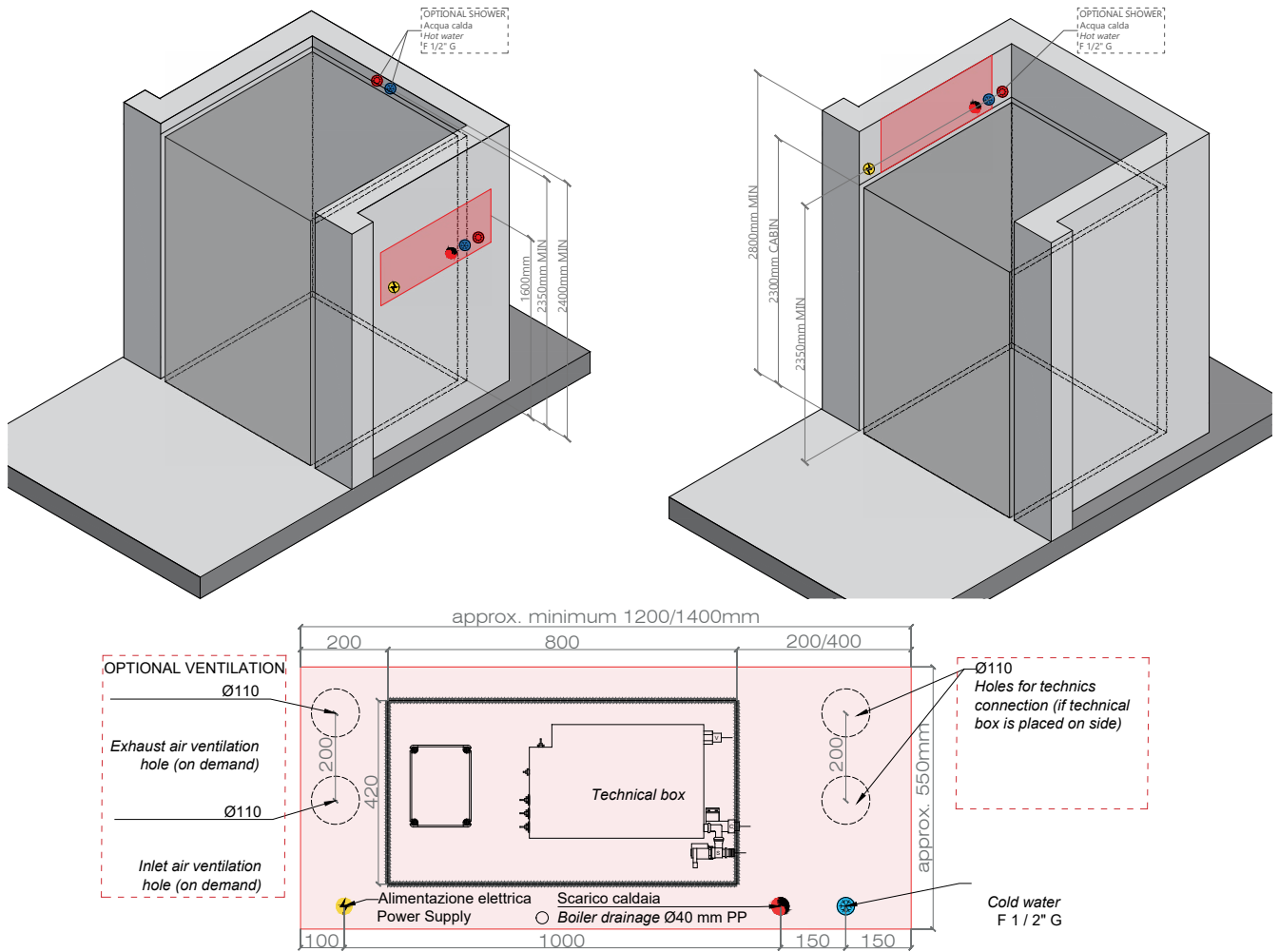

Carmenta Steam Bath needs a steam generator enclosed in a 800x420mm thecnical box that can be placed in a thecnical area on each side of the cabin (left picture) and should be placed at an aproximate height of 1600mm or over the cabin (right picture).

The thecnical general setup drawing is shown above.

Carmenta design, build and tests in compliance with European standards and regulations to ensure maximum safety for the users that is why we ask to comply and follow IEC 364-1 (CEI 64-8) standard for the electrical power system.

Other specifications/requests will be added to the final project on order confirmation.

The Steam generator must be connected to the power grid using a magnetothermal residual current device (10 mA).

Drainage made with PP pipe or other polymer resistant to 100°C Ø 40mm and reduction to Ø 10mm hose.

With only steam bath solution: Cold Water , F 1/2" G

With steam bath and shower solution : Cold Water , F 1/2" G + Hot Water , F 1/2" G.

In order to close the gap between the cabin and the upper floor must be placed a gypsum board with an inspection hatch.

POSITIONING

Steam bath with PET frame

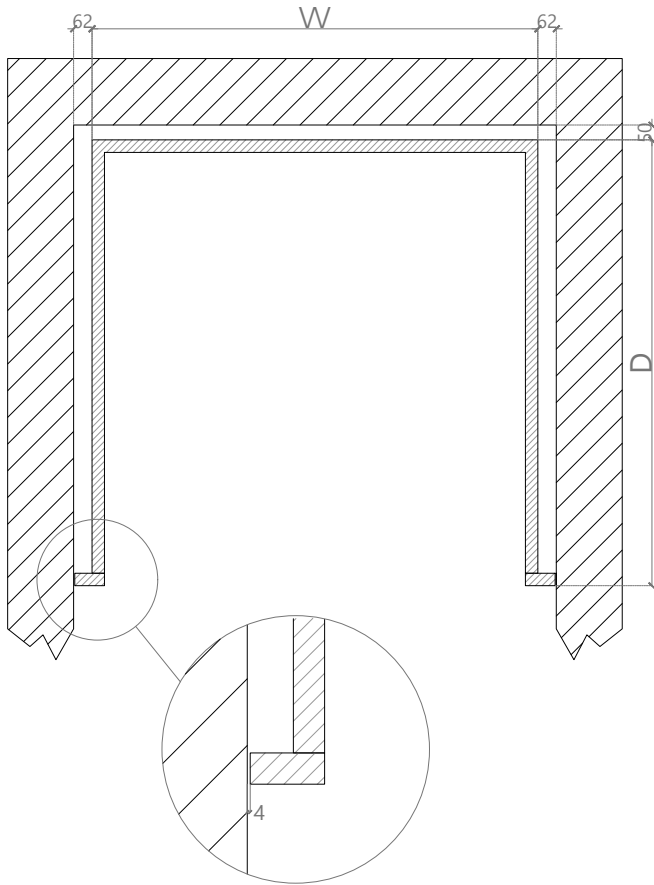

*Minimum gap between the walls and the cabin must be at least 50mm on the back and 62mm on both sides.
Minimum distance from floor to ceiling must be at least 2400mm.
Other solutions can be evaluated based on customer request.*

Steam bath with alluminum frame

W

54

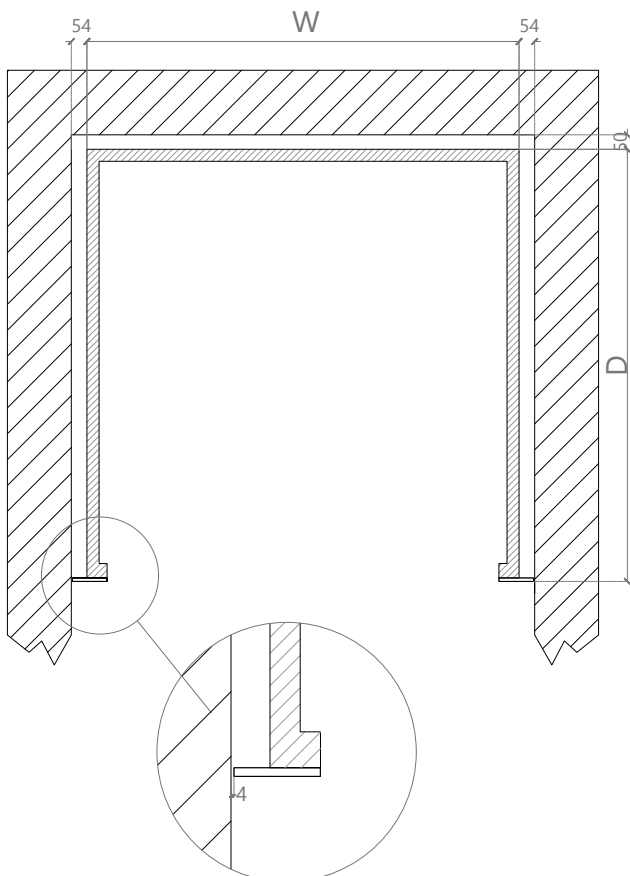

*Minimum gap between the walls and the cabin must be at least 50mm on the back and 54mm on both sides.
Minimum distance from floor to ceiling must be at least 2400mm.
Other solutions can be evaluated based on customer request.*

SHOWER TRAYS DRAINAGE SYSTEMS With Carmenta shower tray

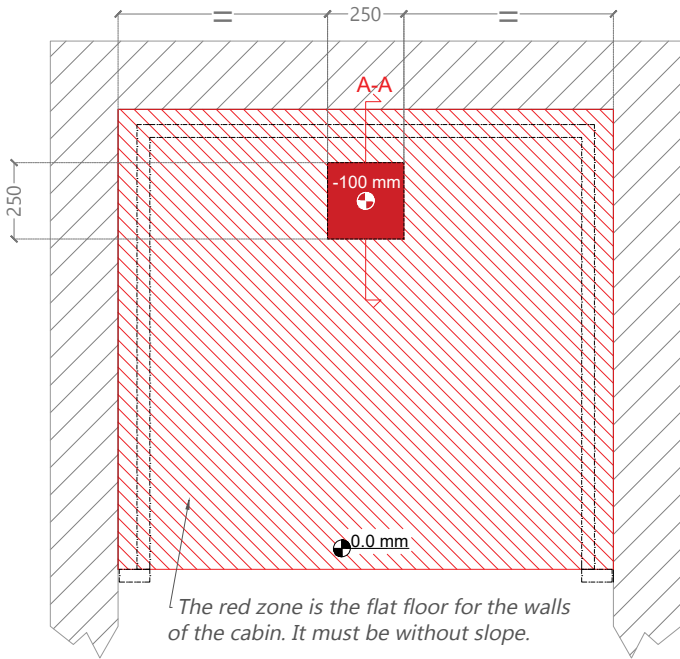

- Floor well for siphoned drainage (-100mm from ground).
- Cabin floor must be flat and without slopes.

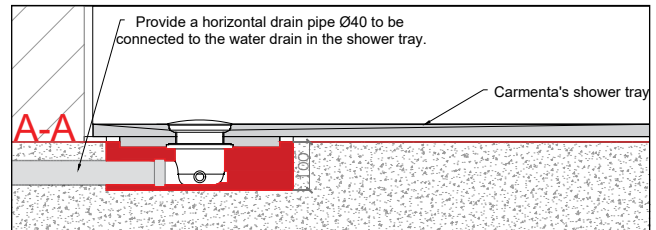

General Section (A-A) for Carmenta shower tray setup
Installation must be done with finished floors and walls.

With tiled loor

Steam bath with PET frame

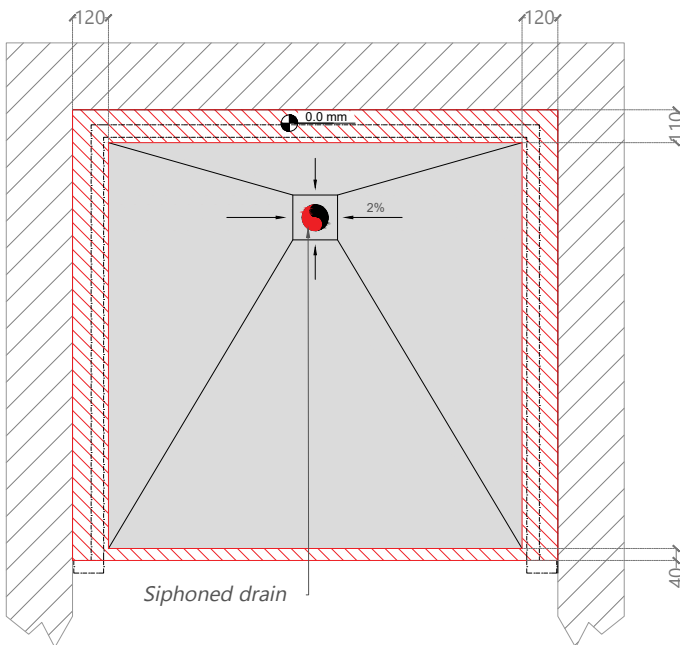

Steam bath with alluminum frame

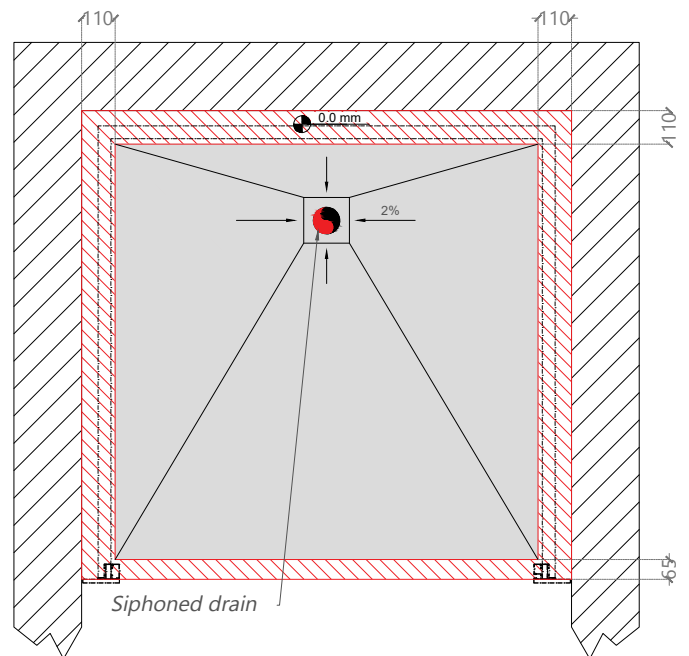

- Cabin floor must be flat and without slopes.
- Tiled floor with 2% slope.

Installation must be done with finished floors and walls.

The specified dimensions are in mm.

INDEX

1. TOOLS REQUIRED FOR ASSEMBLY.....	6
2. STEAM GENERATOR INSTALLATION.....	7
3. SOLID SURFACE SHOWER TRAY (OPTIONAL).....	11
4. TILED SHOWER TRAY	
A. "T" PROFILE WITH PER FRAME.....	12
B. "T" PROFILE WITH ALUMINUM PROFILE.....	13
5. WALLS ASSEMBLY.....	14
6. STEAM PIPE AND KNEIPP CONNECTION.....	15
7. CEILING ASSEMBLY	
A. STANDARD ASSEMBLY.....	16
B. INTERNAL ASSEMBLY.....	17
8. WALLS ASSEMBLY WITH SENSATION COLUMN.....	18
9. DREAM FRAME ASSEMBLY	
A. FRONTAL FRAME.....	20
B. ANGULAR FRAME.....	22
10. PANEL SEALING.....	23
11. ASSEMBLY OF EXTERNAL FRAME.....	24
12. BENCHES ASSEMBLY	
A. TYPE 1.....	25
B. TYPE 2.....	26
C. TYPE 3.....	27
13. FIXED GLASSES ASSEMBLY	
A. WITH PET FRAME.....	29
B. WITH PET FRAME (ANGULAR).....	31
C. WITH ALLUMINUM FRAME.....	32
14. DAM PROFILE ASSEMBLY.....	34
15. FINAL SEALING.....	35
16. DOOR ASSEMBLY.....	36
17. HANDLE ASSEMBLY	
A. TYPE 1.....	39
B. TYPE 2.....	39
18. GASKET ASSEMBLY.....	40
19. BONDING AND SEALING.....	41
20. OPTIONAL	
SHOWERHEAD.....	43
SPOTLIGHT ASSEMBLY.....	46
SPEAKERS.....	46
STEAM OUTLET.....	47
21. ELECTRIC CONNECTIONS.....	48

1. TOOLS REQUIRED FOR ASSEMBLY

Ladder	Pliers	Cutter	Hex key	Phillips screw driver	Electric screw driver	Spirit level	Vacuum pads	Caulking gun *	Adjustable prop
									

* Adhesive* is supplied by Carmenta (it is present only for CE)

SCREWS

USE	TYPE	CODICE
Wall/ceiling fixing (external mounting)	Self-tapping screw 6x100 + washer 8x24	BB
Wall/ceiling fixing (internal mounting)	Stainless steel self-tapping screw 4x70	MB
Fixing aluminum frame with walls	Stainless steel self-tapping screw 4x45	AB
Angular frame union	Stainless steel hexagonal head M5x40	EB
Fixing Thermowood or stainless steel frames	Stainless steel self-tapping screw 3,5x16	CB
Fixing Corian frames	Hexagon socket cylindrical head screw m4x8	DB
TYPE 1 bench/leg assembly	Nut M8 + washer 8x24	KB
TYPE 2 bench/leg assembly	Stainless steel hexagonal head M8x35 + washer 8x24 + NUT	GB
Angular bench connection TYPE 2	Stainless steel hexagonal head M8x35 + washer + NUT	HB
Speaker installation	Self-tapping screw 2,9x13	RB
Wall/glass hinge fixing	Stainless steel self-tapping screw 5x50	LB
Backrest LED frame assembly	Stainless steel self-tapping screw 3,5x35	SB
Stainless steel profile fixing above the door	Stainless steel hexagon socket button head screw M3x35	
LED support on bench	Stainless steel self-tapping screw 4x45	TB
Sensation column fixing on the ceiling	Stainless steel self-tapping screw 5x80	VB
Sensation column front fixing	Stainless steel hexagon socket button head screw M4x16	QB

2. STEAM GENERATOR INSTALLATION

Before assembling the cabin it is necessary to install the steam generator (use the supplied screws and dowels).

Whether the technical compartment is positioned above the cabin or in the adjacent room, the technical compartments must be mounted first to have the possibility of connecting the water, the drain and the steam outlet with ease.

The steam generator must be fitted at least 30 mm from the cabin ceiling and the steam generator boiler discharge must be at a higher level than the siphoned discharge prepared by the customer on site.

Connect the water and the siphon drain prepared on site by the customer to the water and drain outlet of the steam generator.

The steam generator must remain accessible for future maintenance.

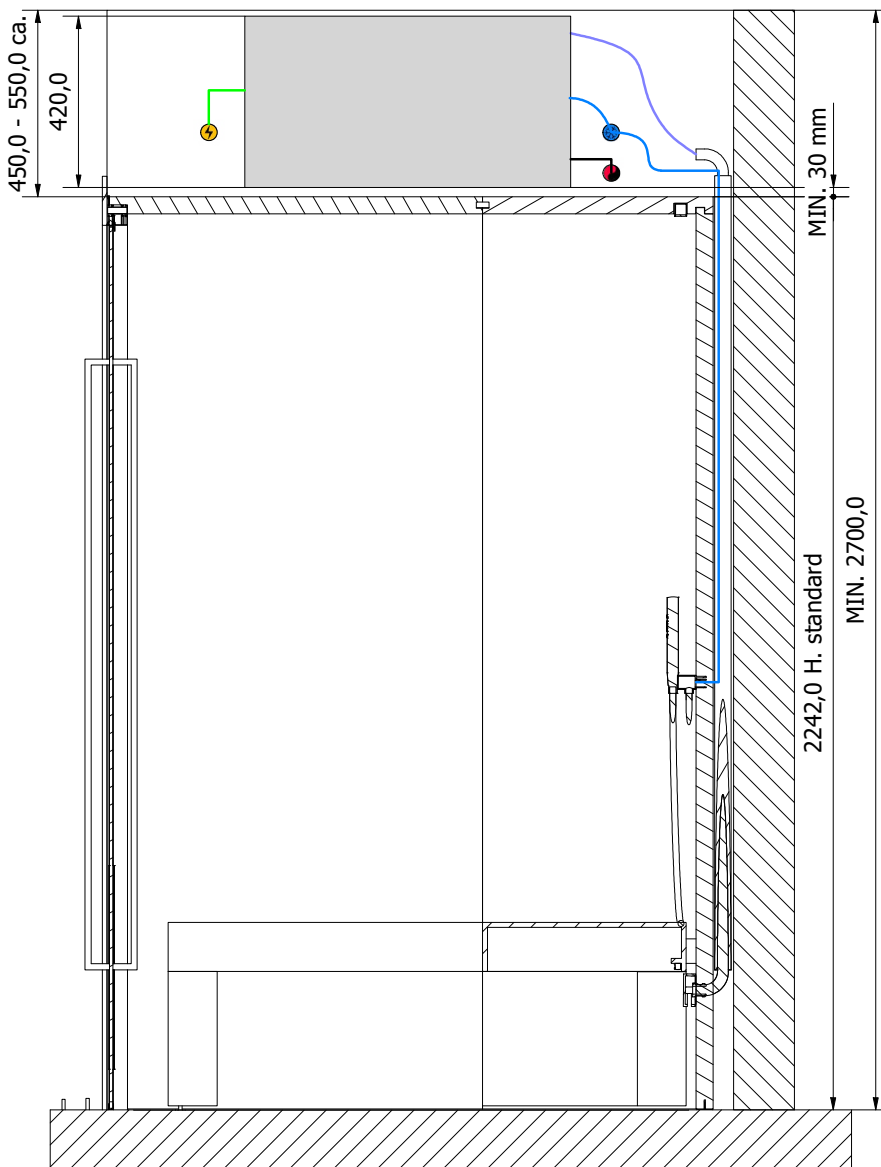





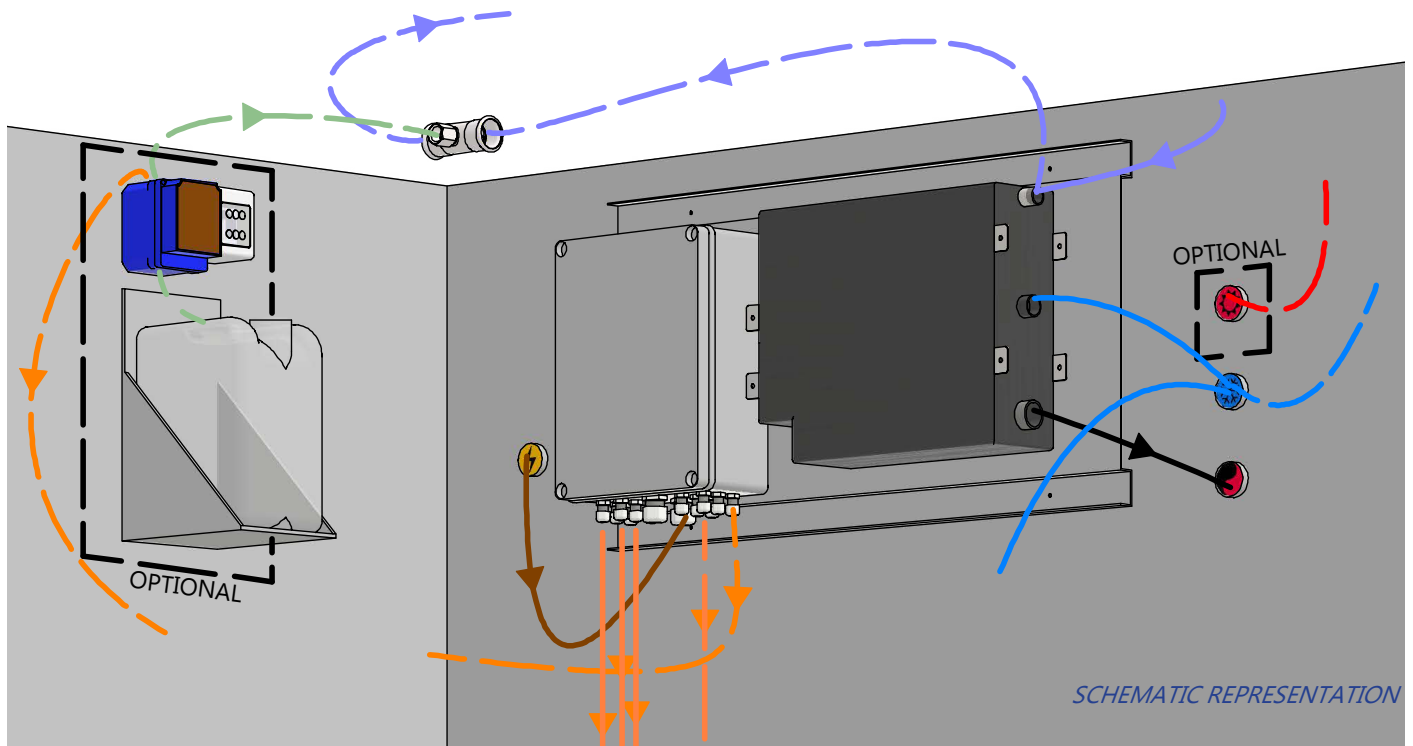

For site requirements, the steam generator can be mirrored.

Above cabin mounting

Once the steam generator and the electrical box have been assembled, arrange all the electrical cables (coming out of the electrical boxes) so that they can be connected easily when the walls are assembled.



-  Cold water connection from cold water supply to steam generator and kneipp
-  Optional with shower head - Cold water connection from cold water supply to steam generator and mixer
-  Optional with shower head - Hot water connection from hot water supply to solenoid valve
-  Drain connection, the pipe must never have an inclination with rising.
-  Steam hose connection from steam generator to steam dispenser. The pipe must never have an inclination with rising steam
-  Optional with aromapump - Connection of the steampipe from the steam generator to the element for inserting the aroma. Then connect the steam hose to the steam dispenser. The pipe must never have an inclination with rising steam
-  Optional with aroma pump - Rilsan aroma tube connection from aroma pump to aroma coupling element

Attention!! the element for the aroma coupling must be positioned above the cabin and must always be lower than the steam outlet point of the steam generator.

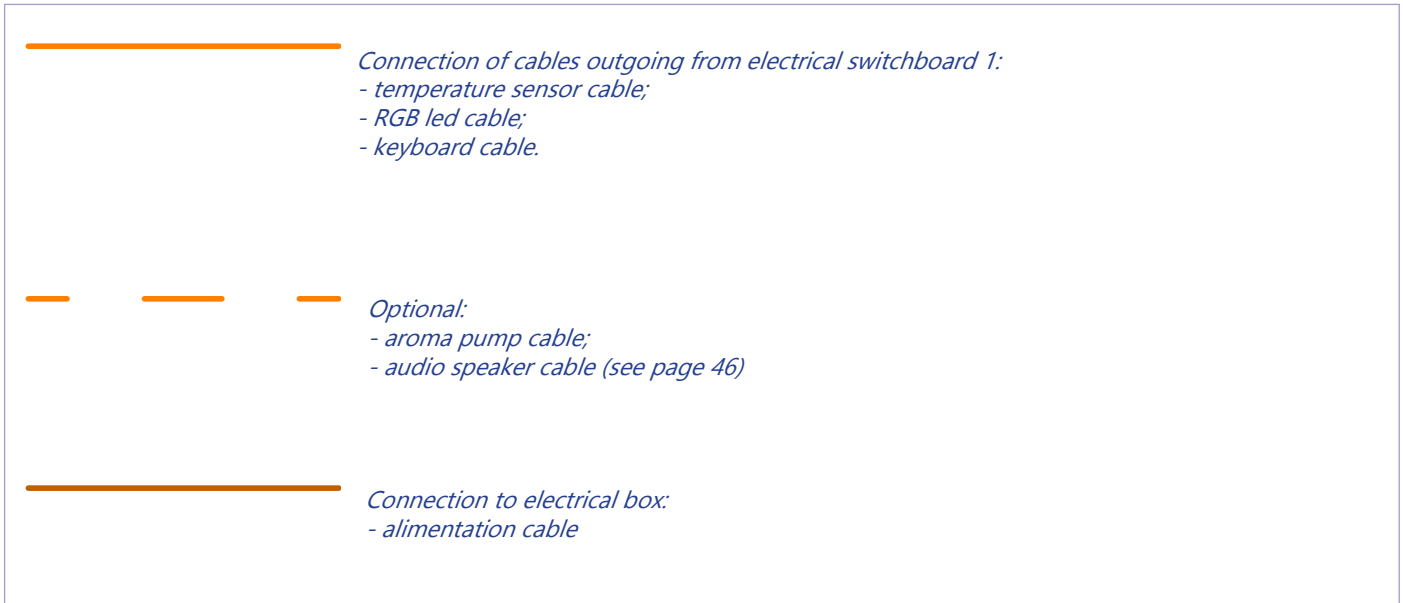

BOILER





With any kind of Control unit and power supply, these are the steps for the connections:

- a) Water connection with cold and soft water and, if possible, demineralized. Minimum pressure 1,5 Bar, Maximum 5 Bar.
- b) Connect the steam pipe to the drainage and clench the tube with the pipe clamp, be sure that it is not too bent. **IMPORTANT: THE PIPE MUST NOT BE TOO BENT OR CLOGGED, TO AVOID OVERPRESSURE** (the connection with the Steam dispenser must be done at the beginning of installation).
- c) Connection of the boiler drain pipe to the drain pipe (the connection to the drain plug must be done in the first stages of assembly)
- d) Open the water and check if there are water leakage.

KNEIPP AND SHOWER

- a) Connect 1 and/or 2 hydraulic hoses to the plumbing (be sure to connect properly cold and hot water). Minimum pressure 0.8 Bar, Maximum 5 Bar.
- b) In some versions, there is a ceiling overhead. In this case, connect the hose and screw head with the gasket.
- c) Connect the hose to the shower holder inside the box and connect the other side of the hose to the hand-shower. Open the water and check if there are water leakage.

SPINOTTI - *PINS*

	<p><i>Keyboard cable (DIS)</i></p>
	<p><i>Sensor cable (carbin ceiling) (ST1 and ST2)</i></p>
	<p><i>RGB leds cables (benches, column or ceiling) (LED1 and LED2)</i></p>
	<p><i>Speckers cable (optional) (MUS)</i></p>

3. PIATTO DOCCIA IN SOLID SURFACE (OPTIONAL) - SOLID SURFACE SHOWER TRAY (OPTIONAL)

To position the shower tray correctly, make sure that the support surface is perfectly horizontal and has no unevenness. The tray must be fitted perfectly coplanar to avoid drainage and installation problems the box. Then position the shower tray making sure it is centered with respect to the width of the walls if in a niche.

- A.** Connect the drain (included) in the prepared well (the intervention of a plumber is required for connection)
- B.** Position the shower tray respecting the distances given and glue it with silicone or foam to the floor
- C.** Finish by assembling the internal parts of the drainage

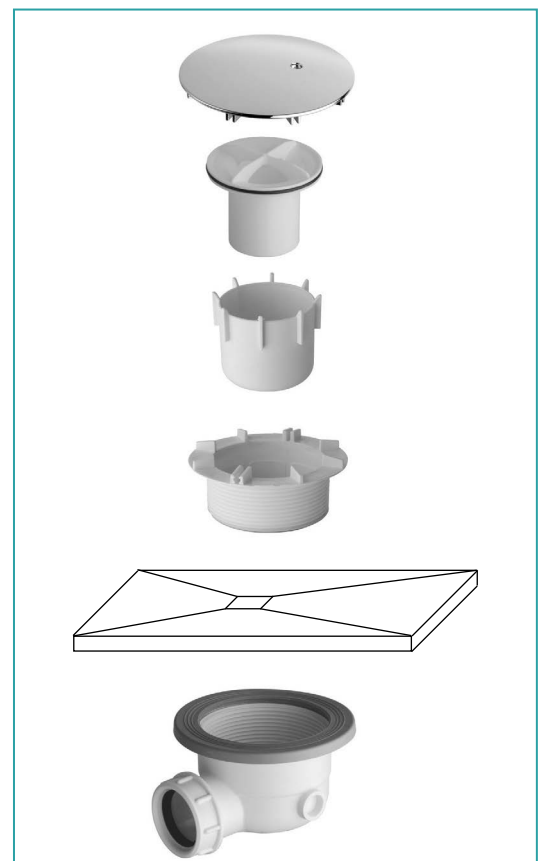
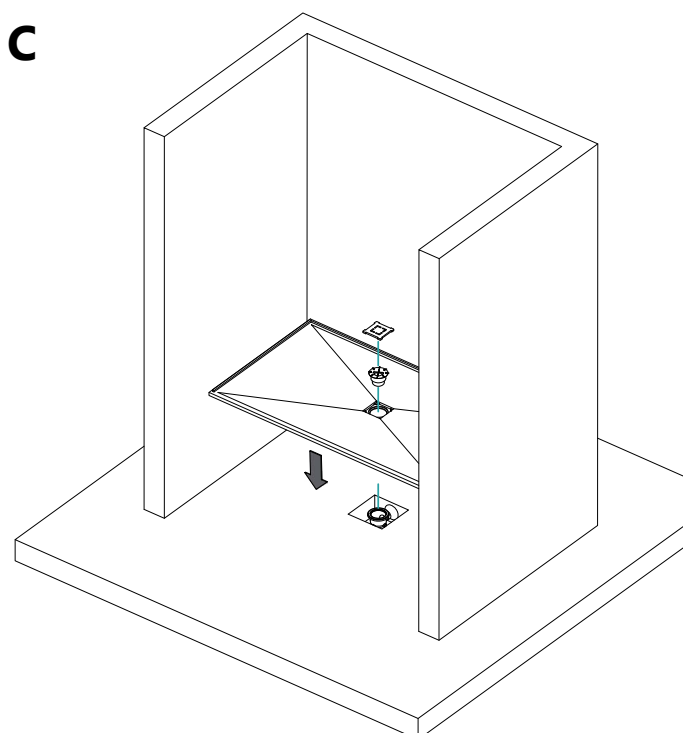
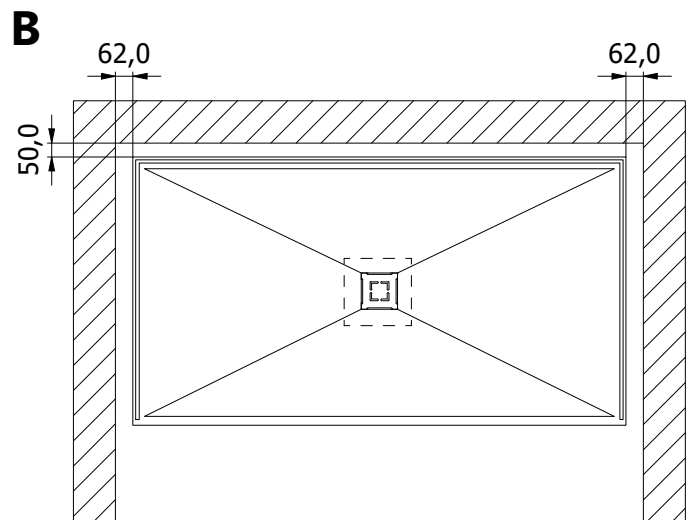
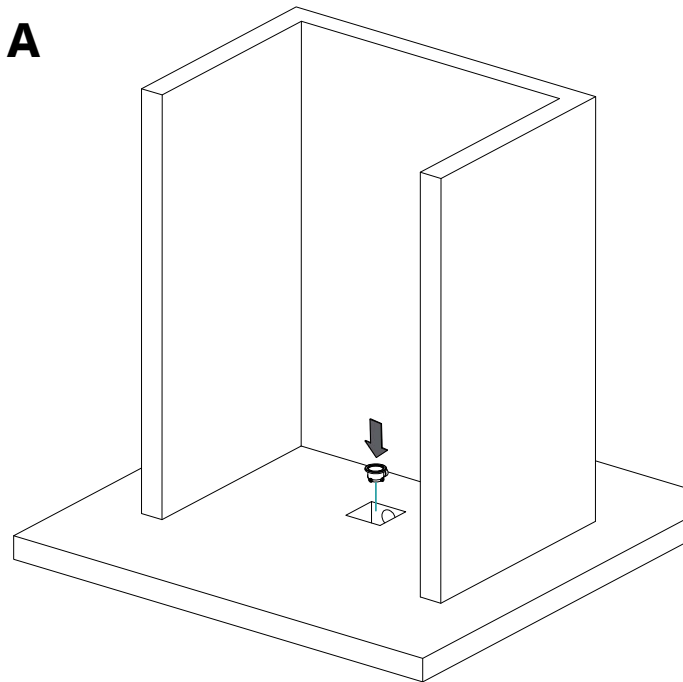

4. PIATTO DOCCIA PIASTRELLATO - TILED SHOWER TRAY

A. T" PROFILE WITH PET FRAME

For correct positioning of the cabin, the part where it rests must be perfectly flat, without bumps or unevenness. The shower tray must have a 2% slope towards the drainage, the drainage is not included.

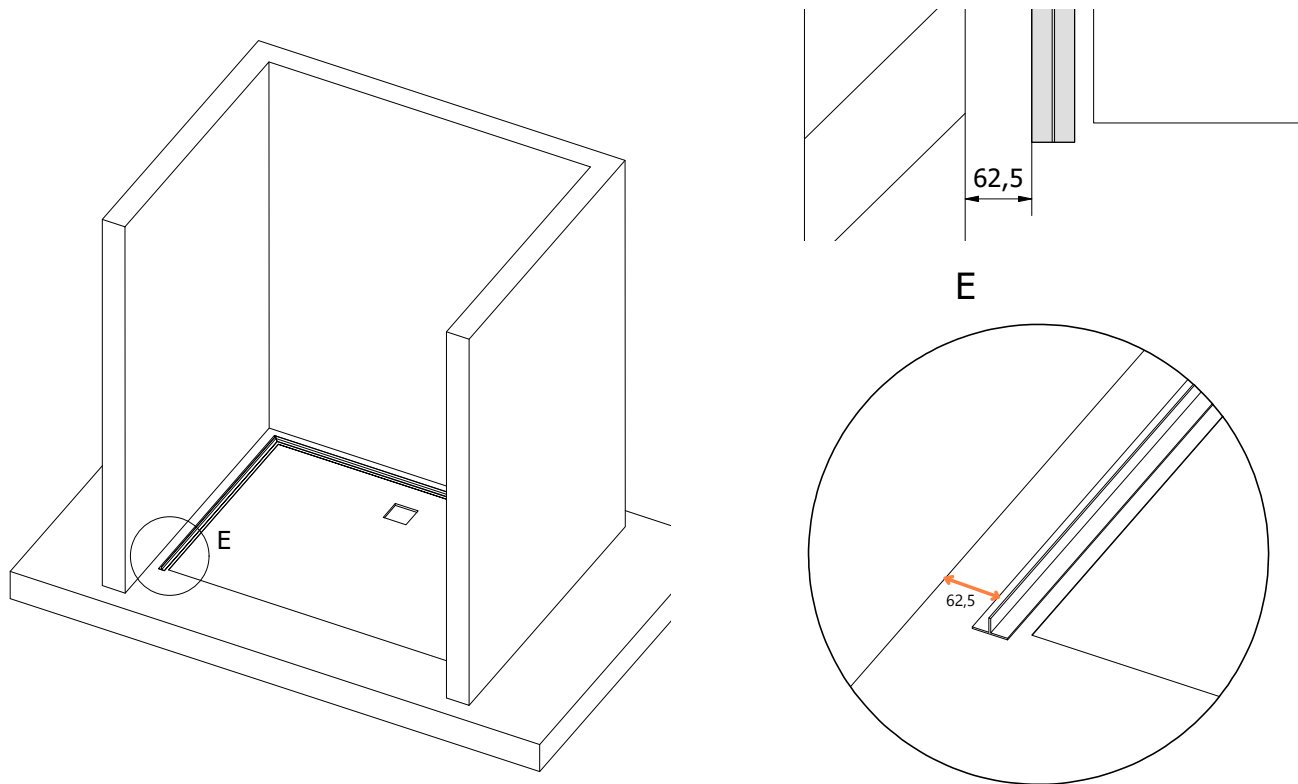

Glue the "T" profile to the ground with double-sided adhesive the polyurethane glue (see page 42).

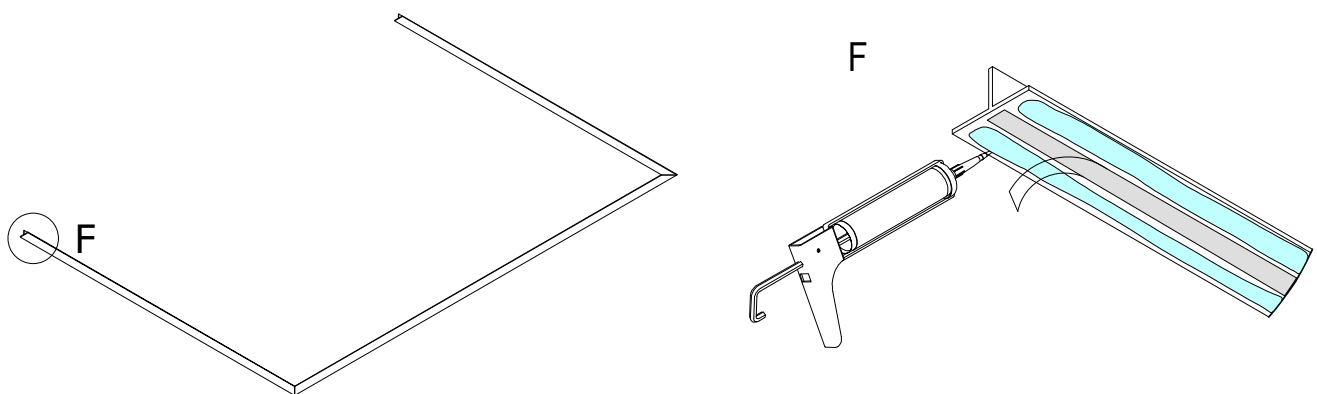

B. T" PROFILE WITH ALUMINUM FRAME

For correct positioning of the cabin, the part where it rests must be perfectly flat, without bumps or unevenness. The shower tray must have a 2% slope towards the drain, the drainage is not included.

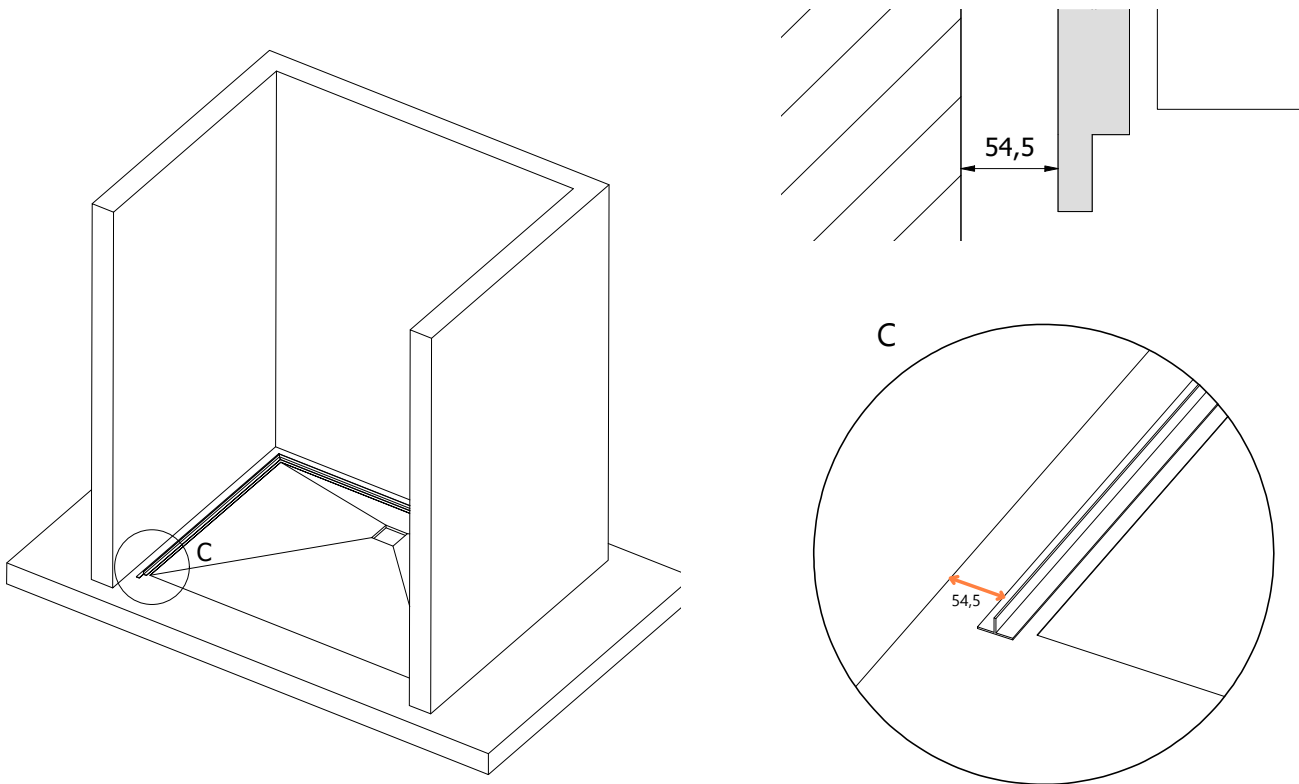

Glue the "T" profile to the ground with double-sided adhesive and the polyurethane glue (see page 42).

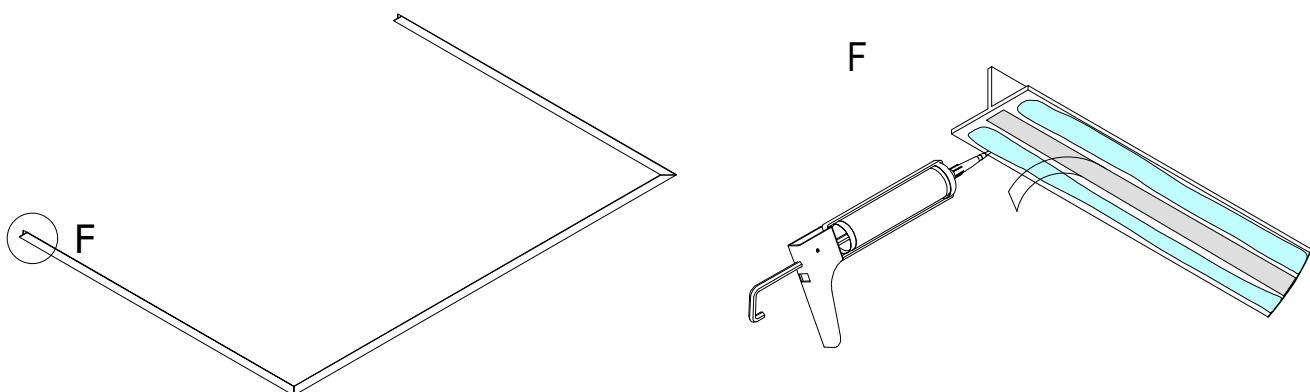

5. WALLS ASSEMBLY

Start the assembly of the walls from the left corner, the assembly is performed thanks to the joints inserted in the panels. Apply the adhesive (see diagram below) and insert the protruding screw (photo A) into the joint (photo B) then lower the panel.

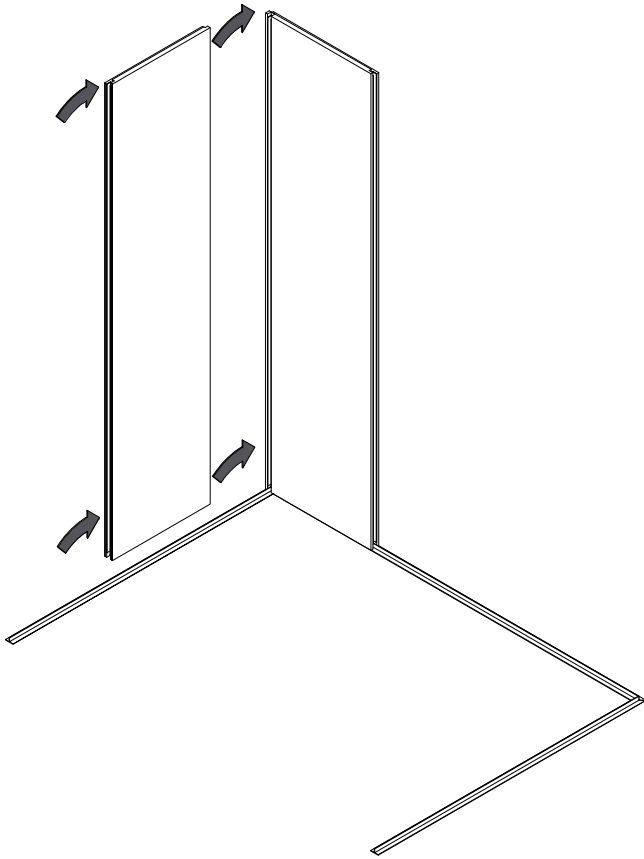

Proceed with the other walls.
The numbering of the walls starts from the left.

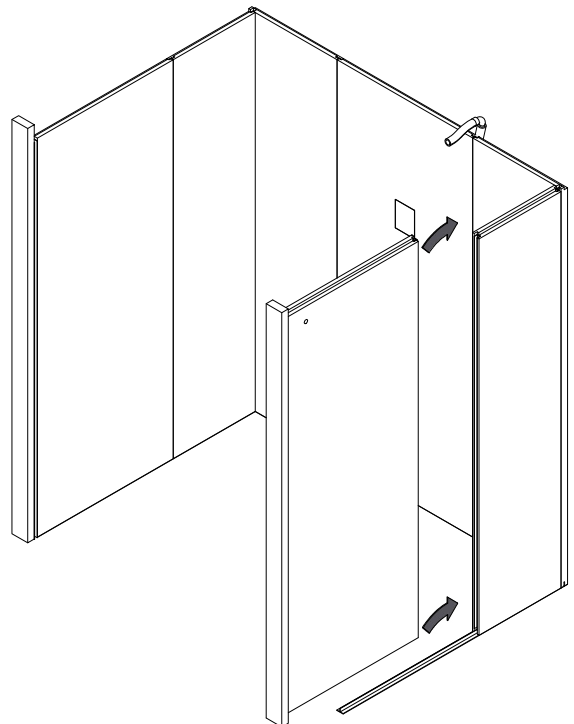
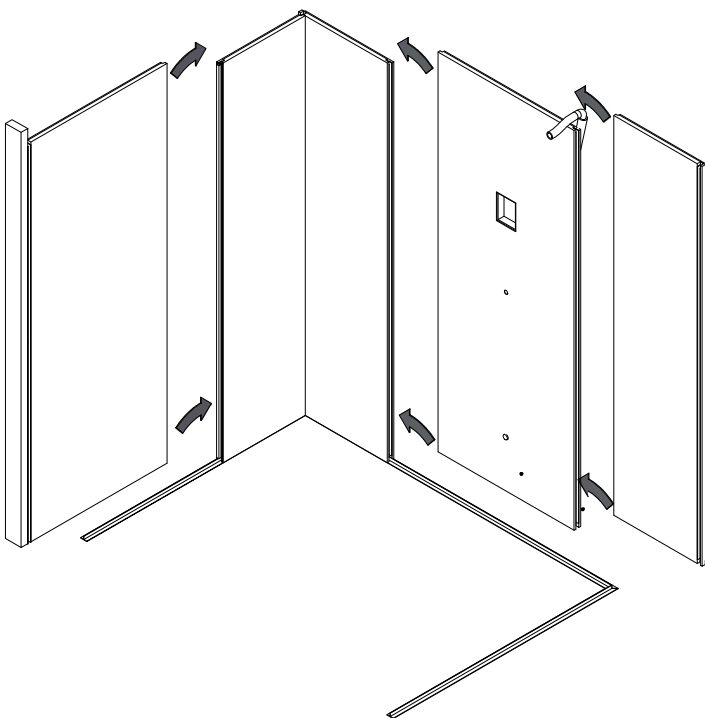
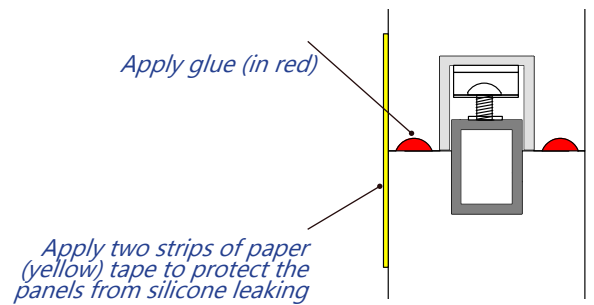
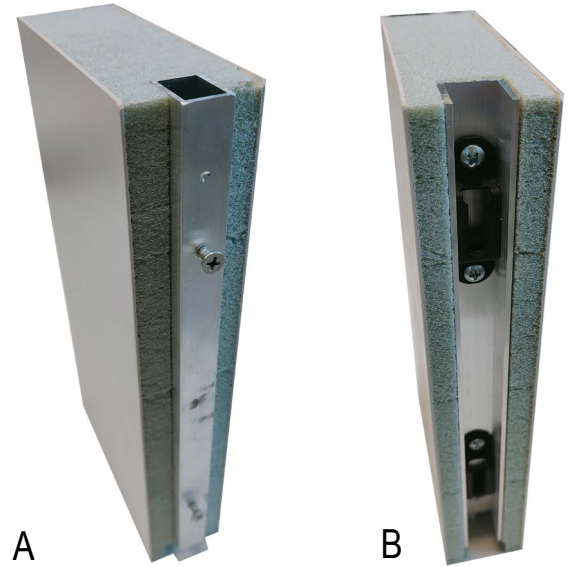

6. STEAM PIPE AND KNEIPP CONNECTION

It should be noted that the steam generator must be placed at a higher height than the steam outlet point located in the cabin and that the pipe must never have an inclination and slope with steam rising.

The creation of siphon becomes a source of noise and danger of overpressure.

Connect the pipe coming from the steam generator to the steel pipe already mounted on the cabin wall and fix it with a hydraulic clamp.

Connect the pipe coming from the kneipp to the cold water with the supplied hoses.

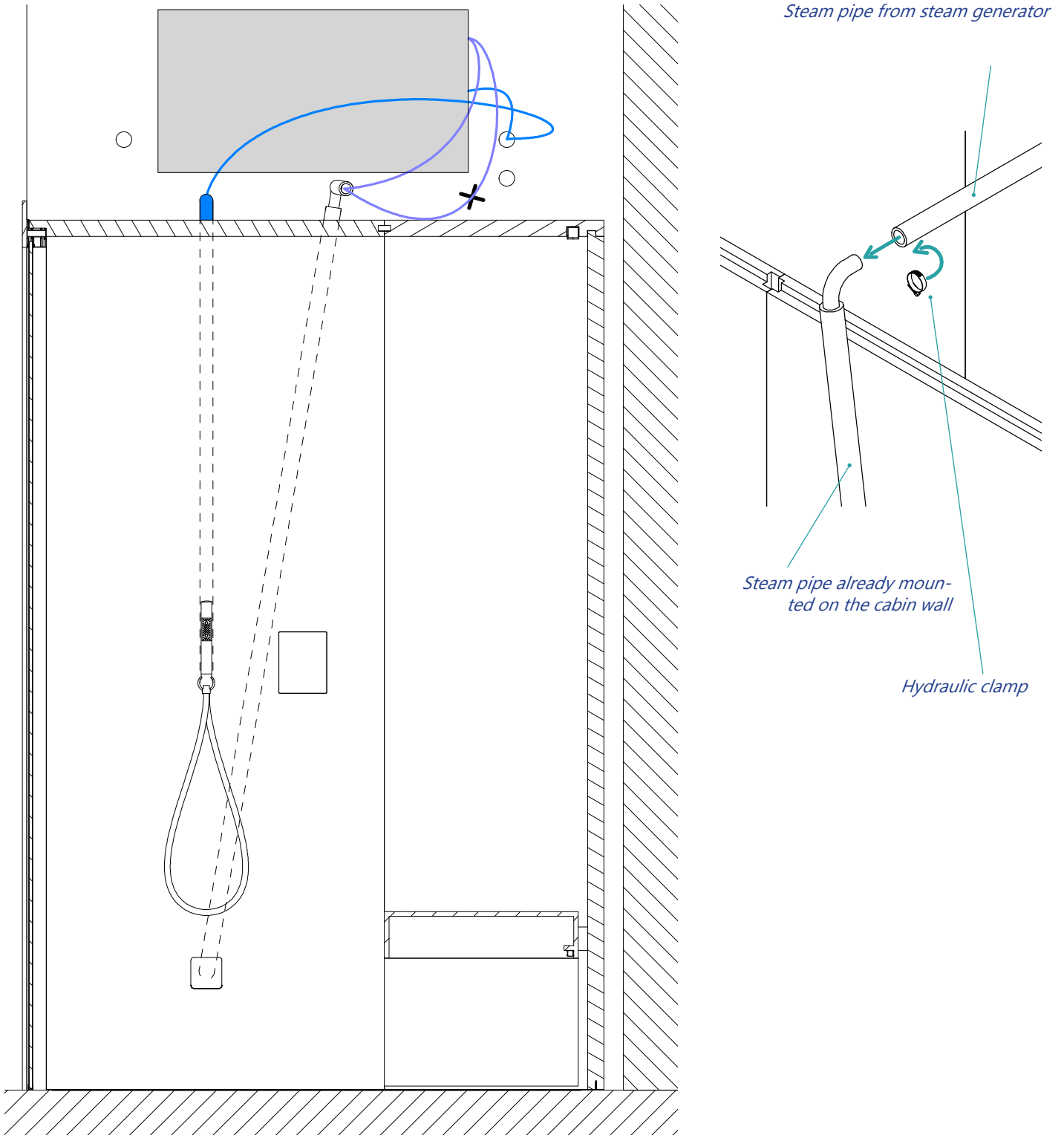

7. CEILING ASSEMBLY

The ceilings of the cabin will be screwed from above.

When the cabin is angular, support the cantilevered corner with adjustable props until the front frame is assembled.

Apply the glue in the ceiling channel see fig. B, fix the ceiling with the supplied screws

Attention!!! tighten moderately, the head of the screw must reach flush with the wall and must not go beyond, see fig. A

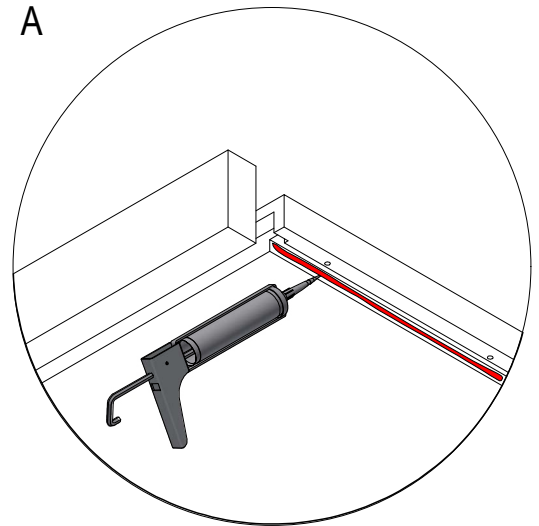
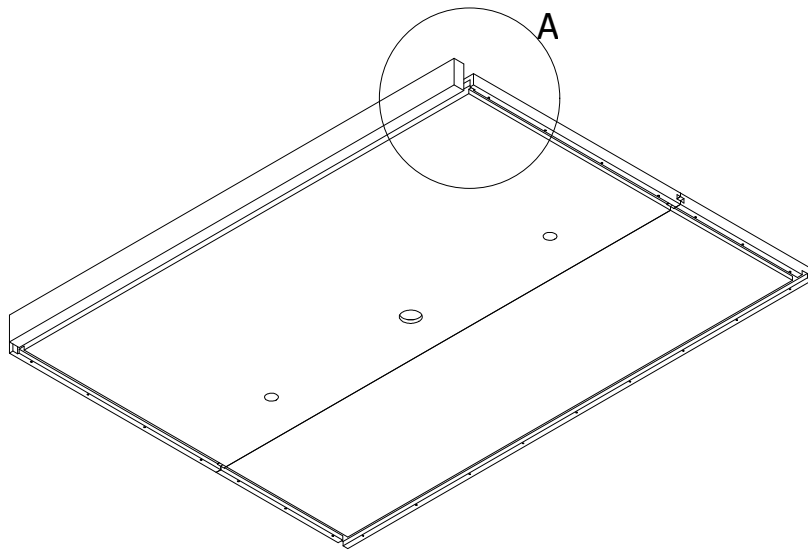

Apply glue (in red)

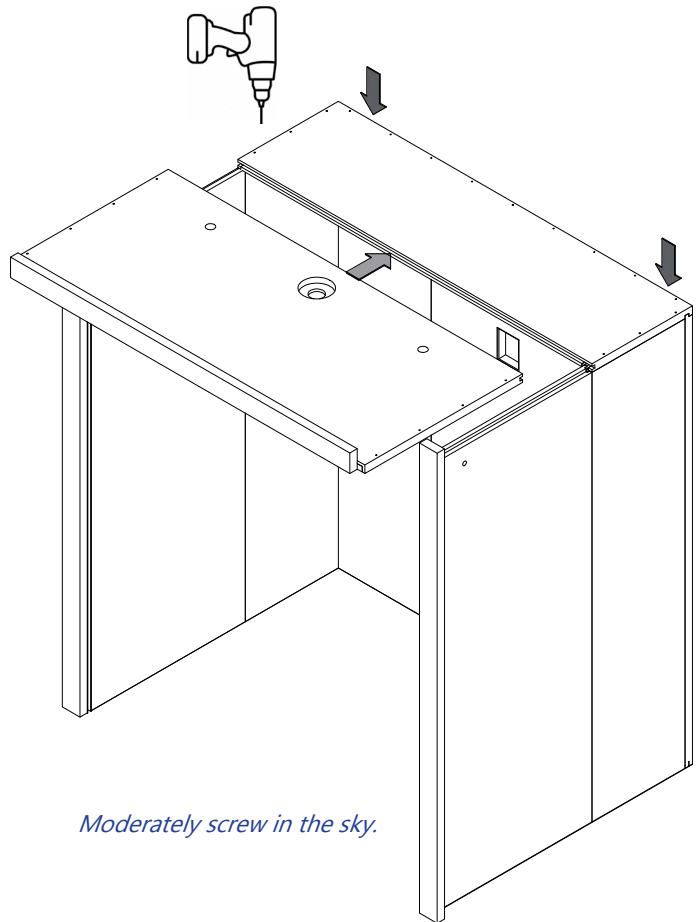
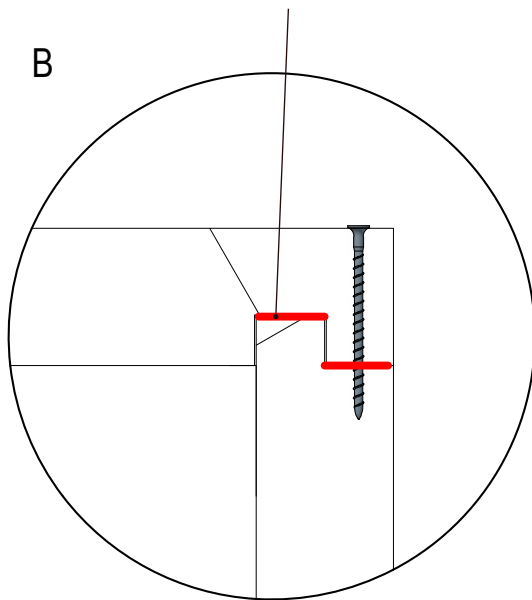

Moderately screw in the sky.

Use xx screws.

B. INTERNAL ASSEMBLY

When the height of the room does not allow assembly from above, the cabin is ready for inner screwing. There must be at least 100 mm above the sauna to allow the panels to move.

Fix the ceiling from inside the cabin with the screws provided using the holes already present on the walls.

Attention!!! tighten moderately, the head of the screw must reach flush with the wall and must not go beyond, see fig. A
When the cabin is angular, support the cantilevered corner with adjustable props until the front frame is assembled.

Only after the final sealing (see page 23) apply the cover frame of the screws over the entire perimeter, fixing it with double-sided adhesive and glue as in fig. B.

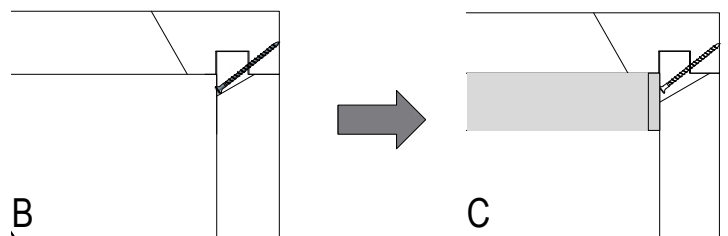
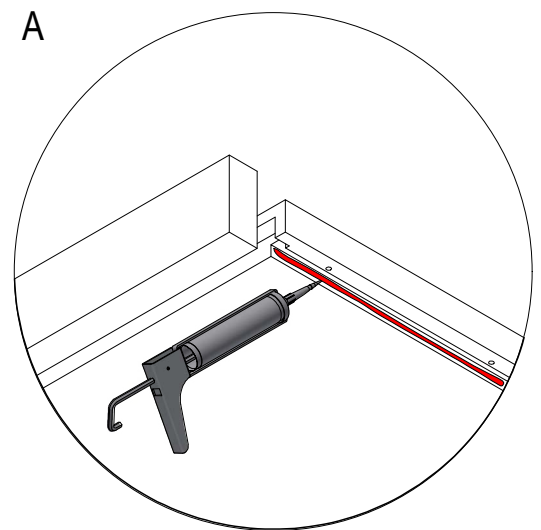
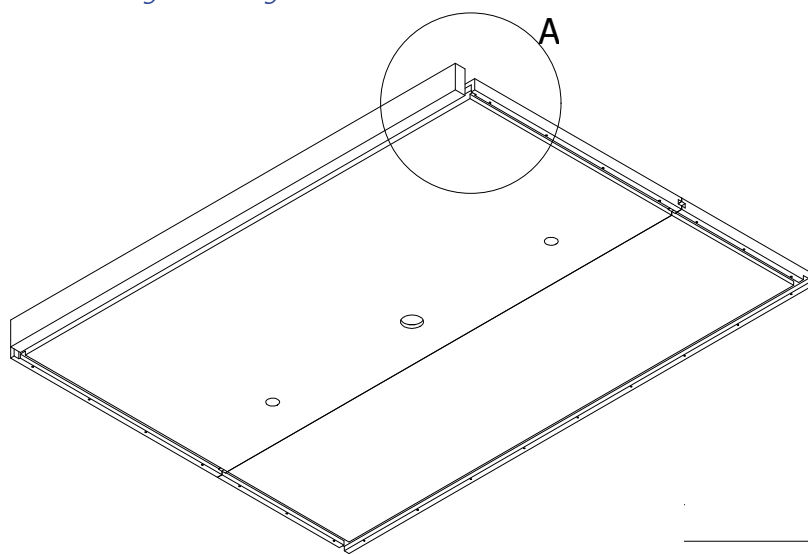

Screw the tops from the inside thanks to the holes already present on the panels (fig. B) and cover the holes with the frames supplied with double-sided adhesive and glue (fig. C).

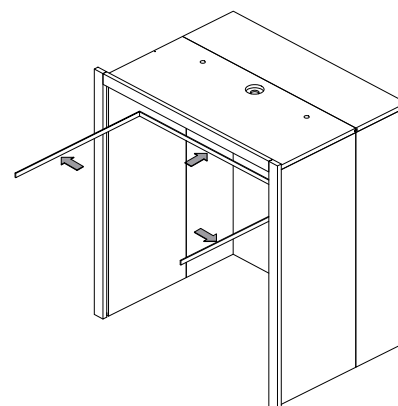
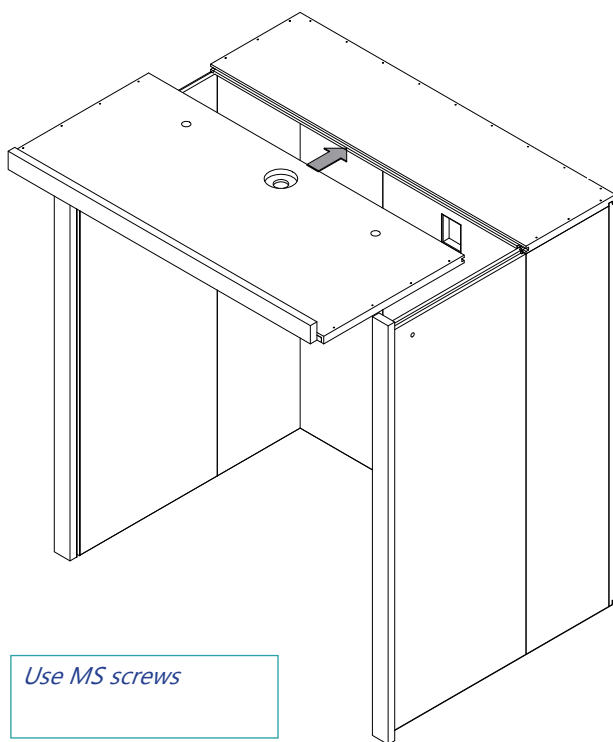

8. WALLS ASSEMBLY WITH SENSATION COLUMN

*Hook the column following the assembly sequence. Silicone the corner between the wall and the column.
The numbering of the walls starts from the left.*

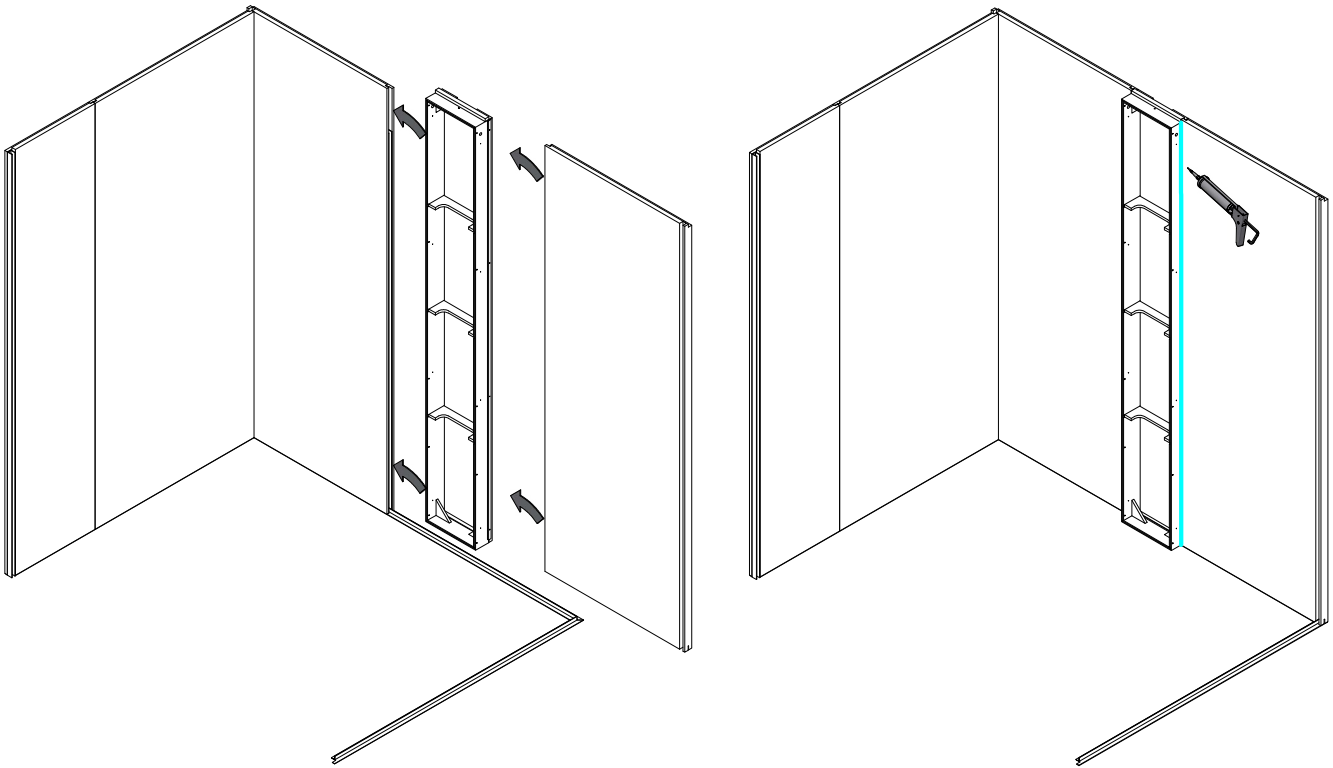

After assembling the ceiling, fix the column with the screws provided.

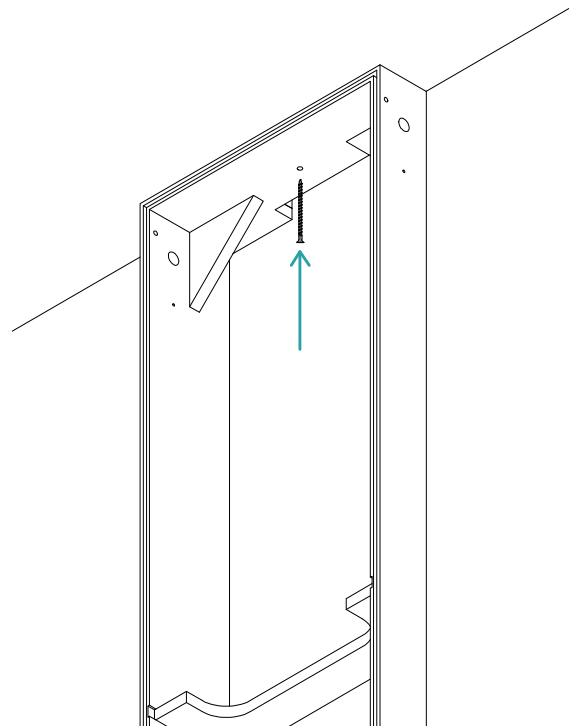
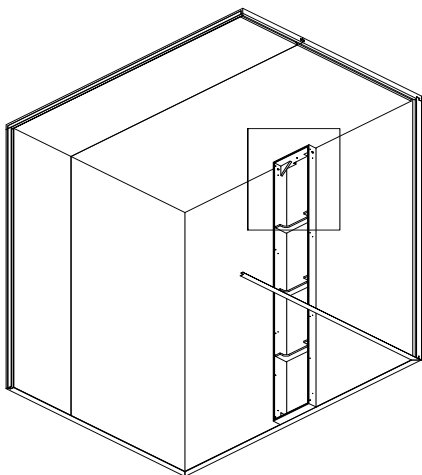

Use VB screws

After assembling the walls and the ceiling, fix the front panel of the column, after having made all the electrical and hydraulic connections of the various components, with the screws provided.

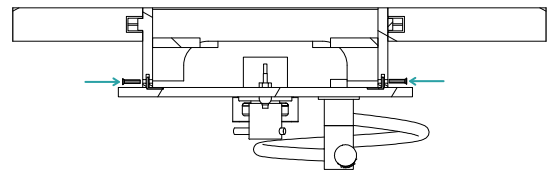
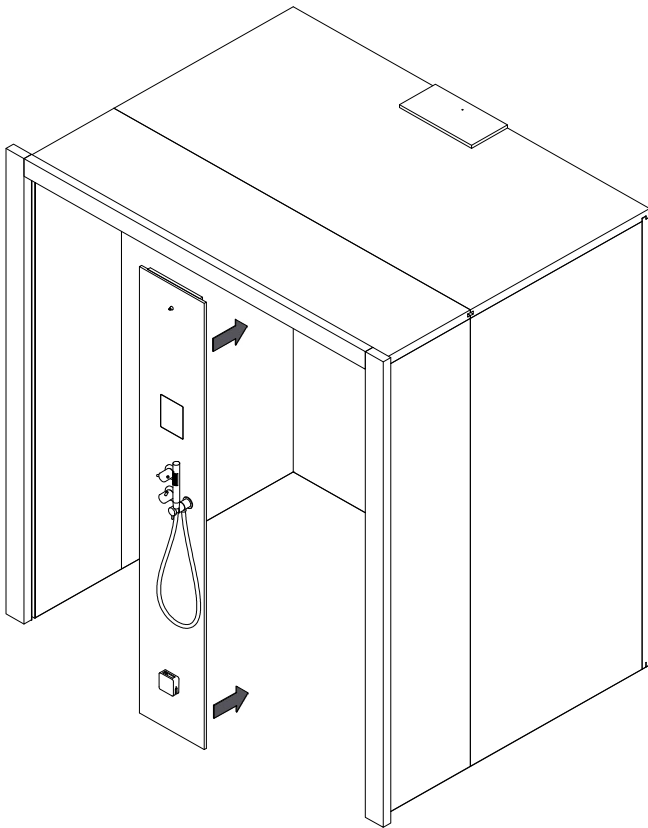

Use QB screws

9. DREAM FRONT FRAME ASSEMBLY

A. FRONTAL FRAME

Fix the frame to the walls with the supplied screws using the holes on the frame.
 (The cabins of the Matrix, One and Sensation collections have the front frames and frames already fixed to the ceilings and walls.)

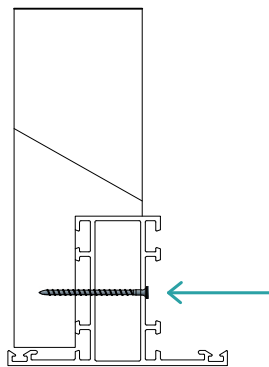
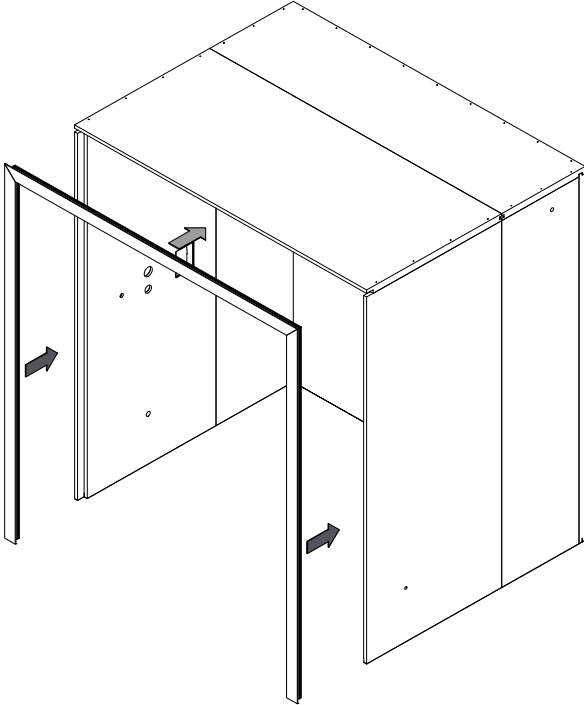

Joining the side frame with the panel

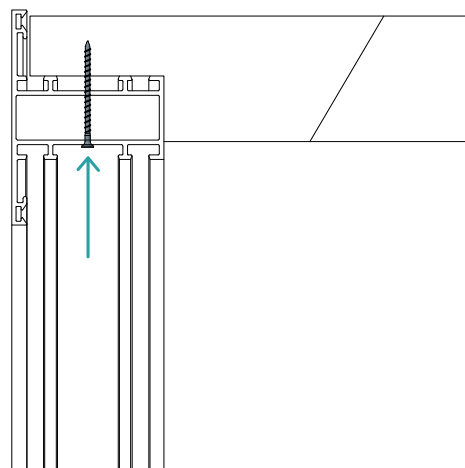

Joining the upper with the ceiling

Use MS screws

If the alluminum frame arrives on site disassembled (when it is large) it will be necessary to assemble it using the corner pieces following these steps:

- 1) fit the brackets supplied;*
- 2) tighten the brackets with the Allen screws.*

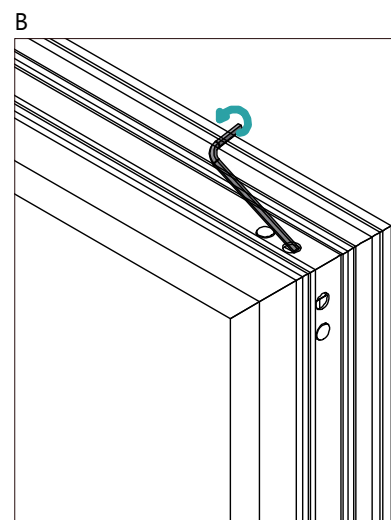
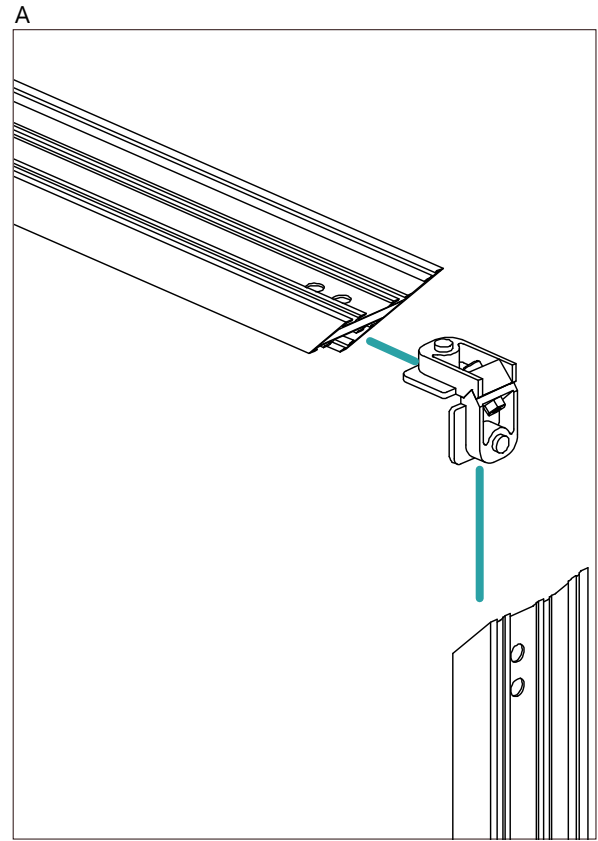
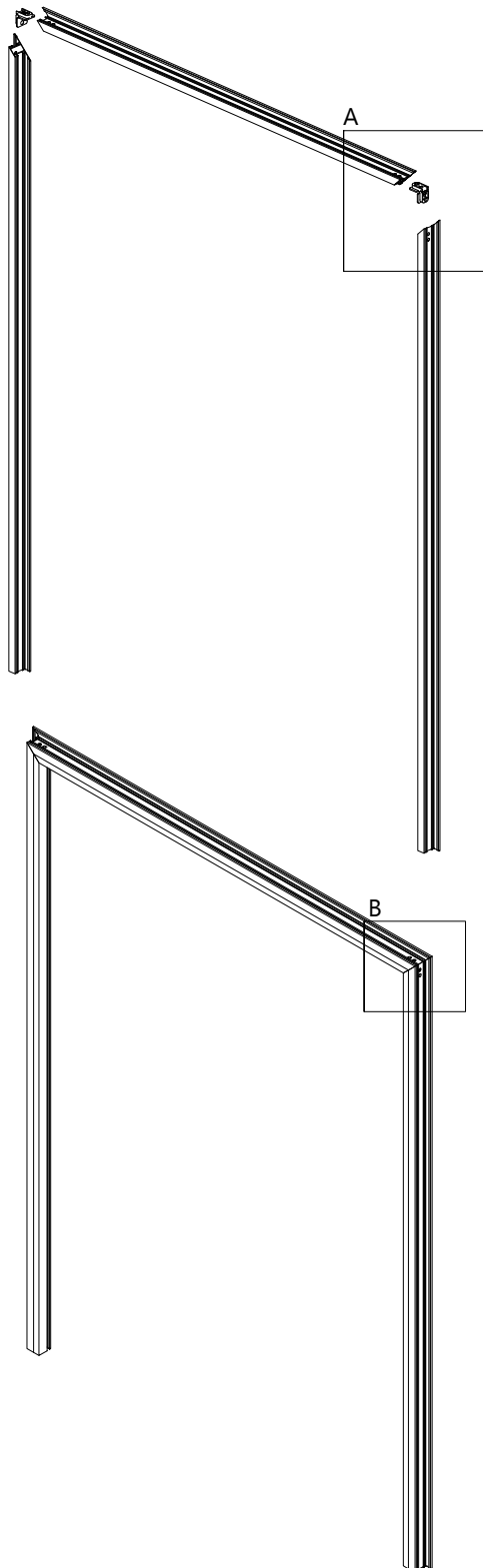

Lock the two frames by tightening the socket-head screw.

B. ANGULAR FRAME

When the cabin has an angular frame, fix the aluminum frames together and screw the frame to the structure.

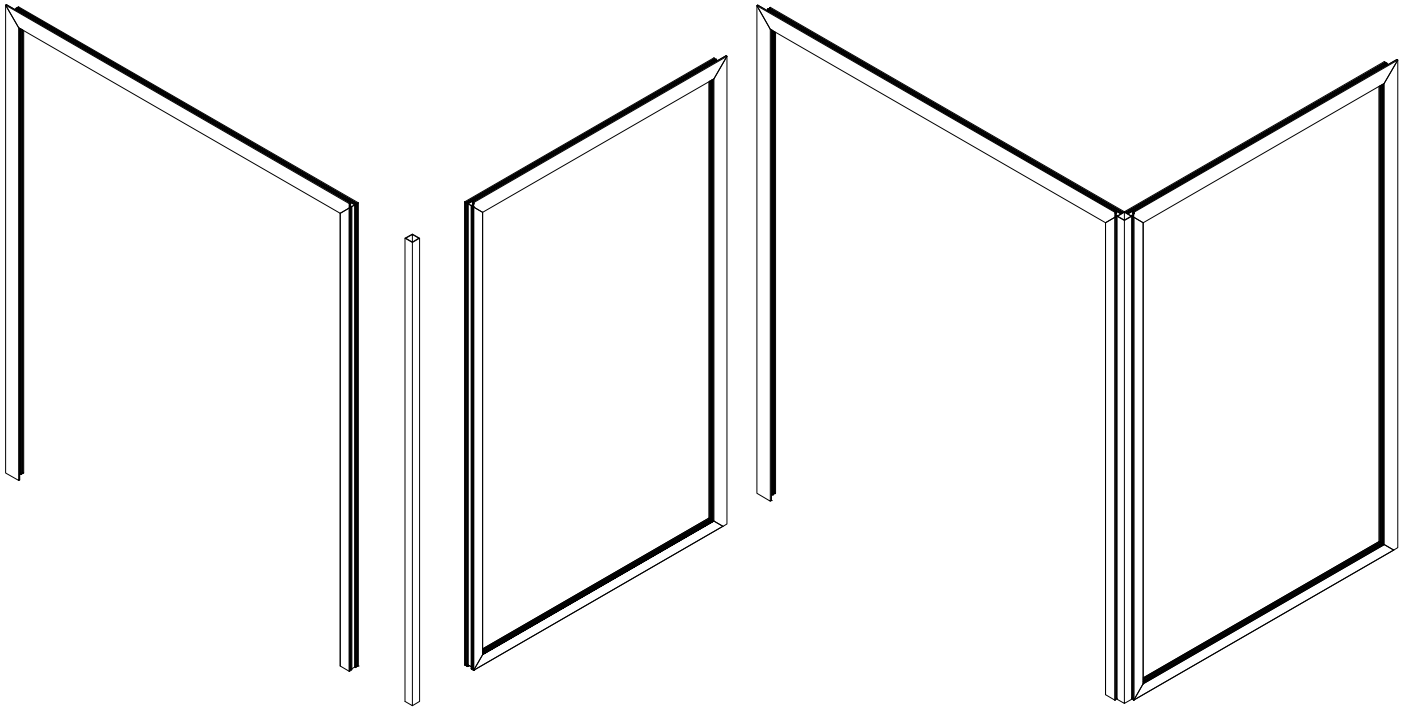

For fixing the frame to the wall see previous page and detail below.

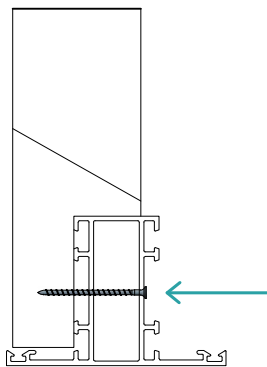

Joining the side frame to the panel with screw

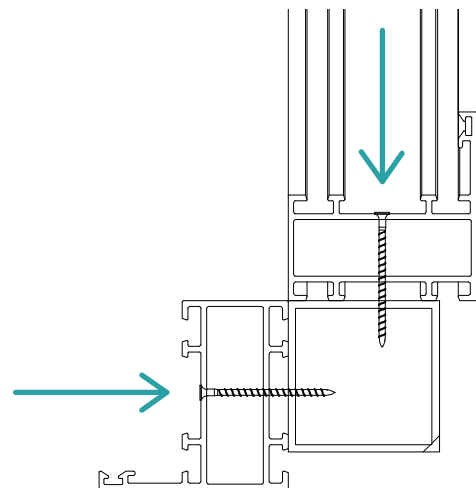

Angular frame union

Use AB screws

Use EB screws

10. PANEL SEALING

Spread a continuous bead of silicone (see table on page 41) along the internal perimeter of the entire booth to seal it. Spread the silicone on all the internal corners as indicated in drawings A-B-C.

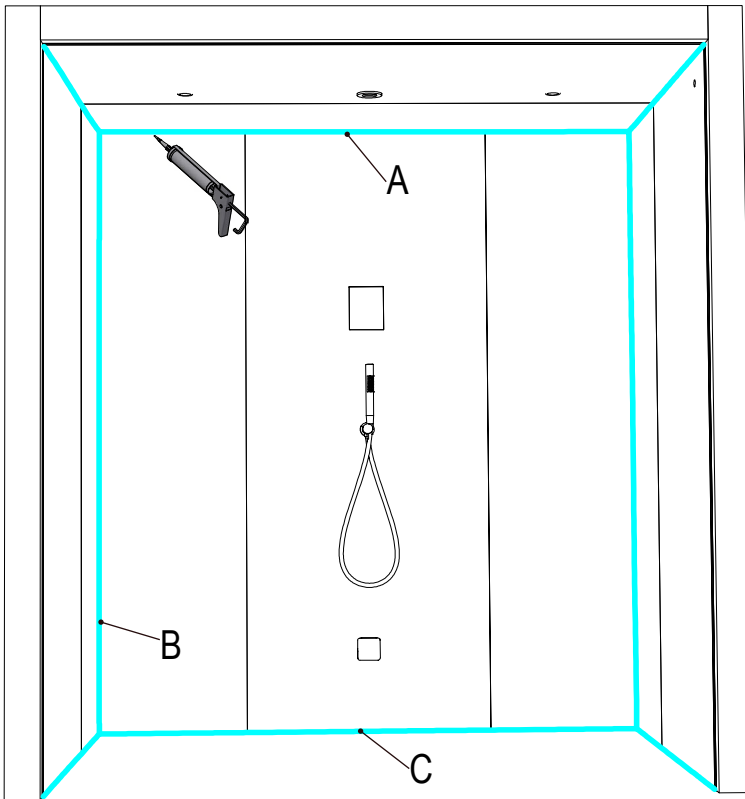

A *Silicone between walls and ceiling in HPL*

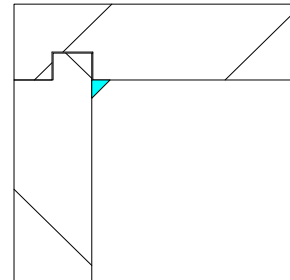

B *Silicone on vertical corners*

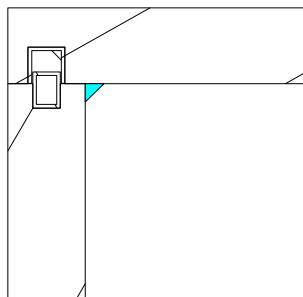

C *Silicone between walls and floor*

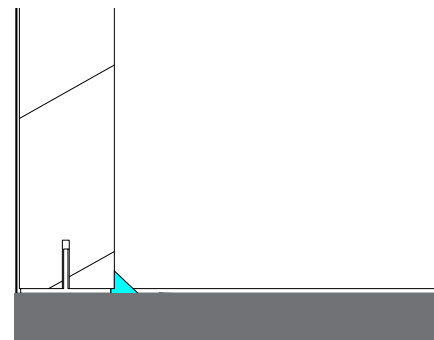

Silicone corner between aluminum frames and walls

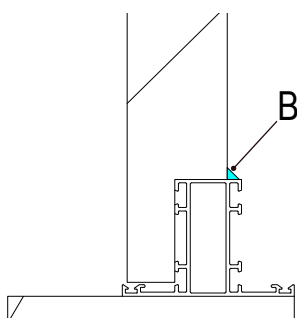

Silicone the corner between the aluminum frames and the ceiling

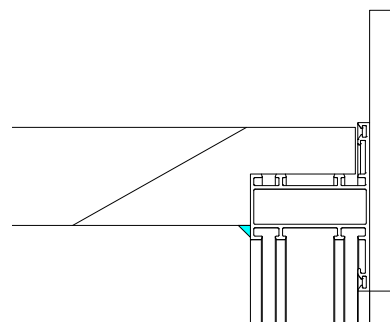

11. ASSEMBLY OF EXTERNAL DREAM FRAME

When there is the aluminum frame there will be the external frames to be assembled. The frames can be in:

- wood;
- Corian;
- stainless steel.

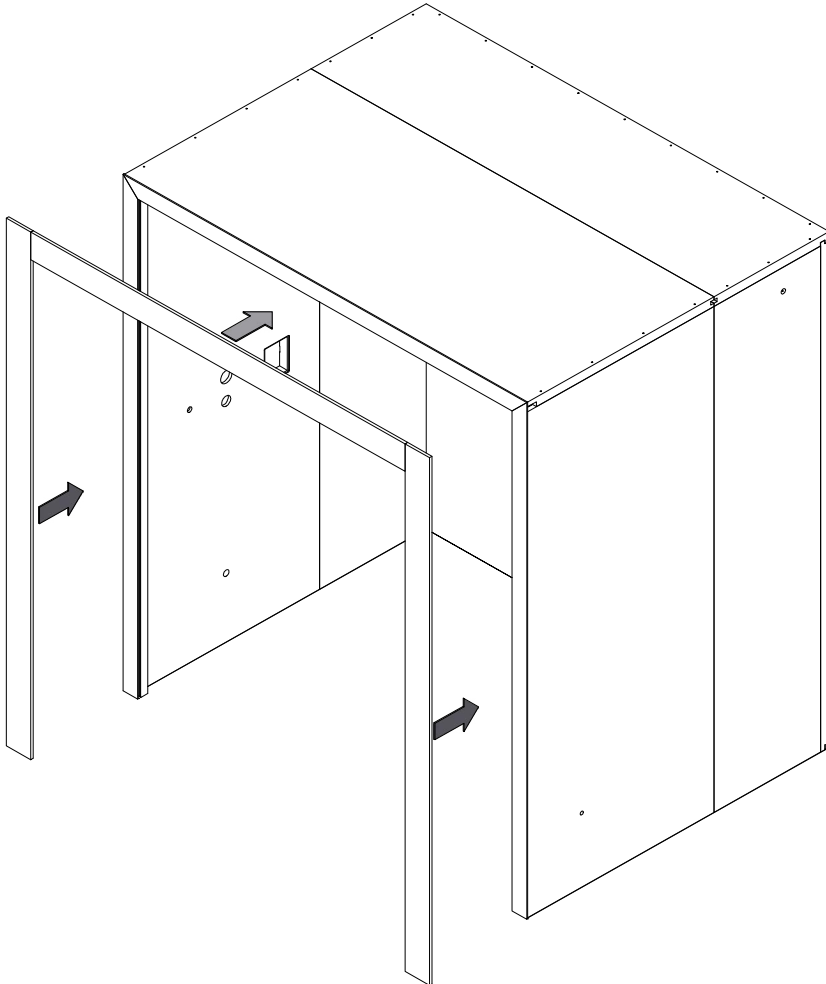

Use the following screws according to the frame material:
WOOD: CB
CORIAN: DB
STAINLESS STEEL: CB

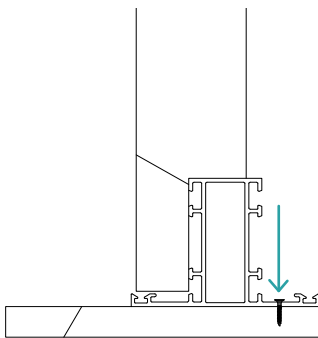

Fixing vertical frames with screws

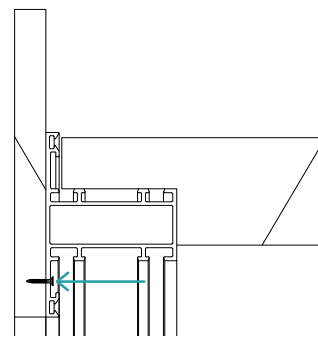

Fixing Horizontal frames with screws

12. BENCHES ASSEMBLY

Benches are of three types:

TYPE 1



Stool that arrives already assembled.

TYPE 2

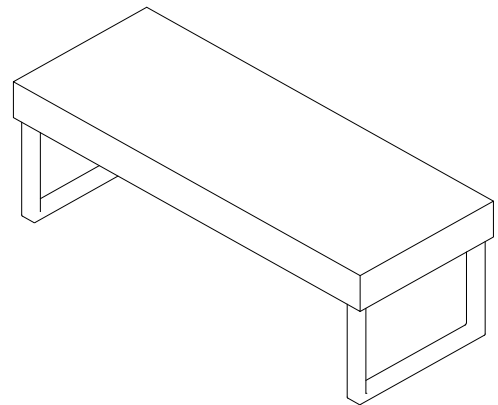

TYPE 3

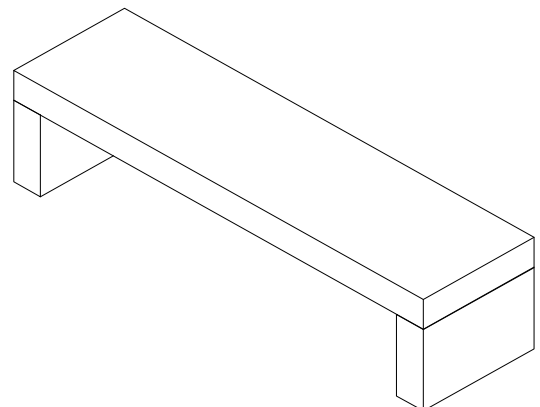

TYPE 2

The benches with steel legs are assembled by screwing the nuts on the pins of the plate mounted under the bench.

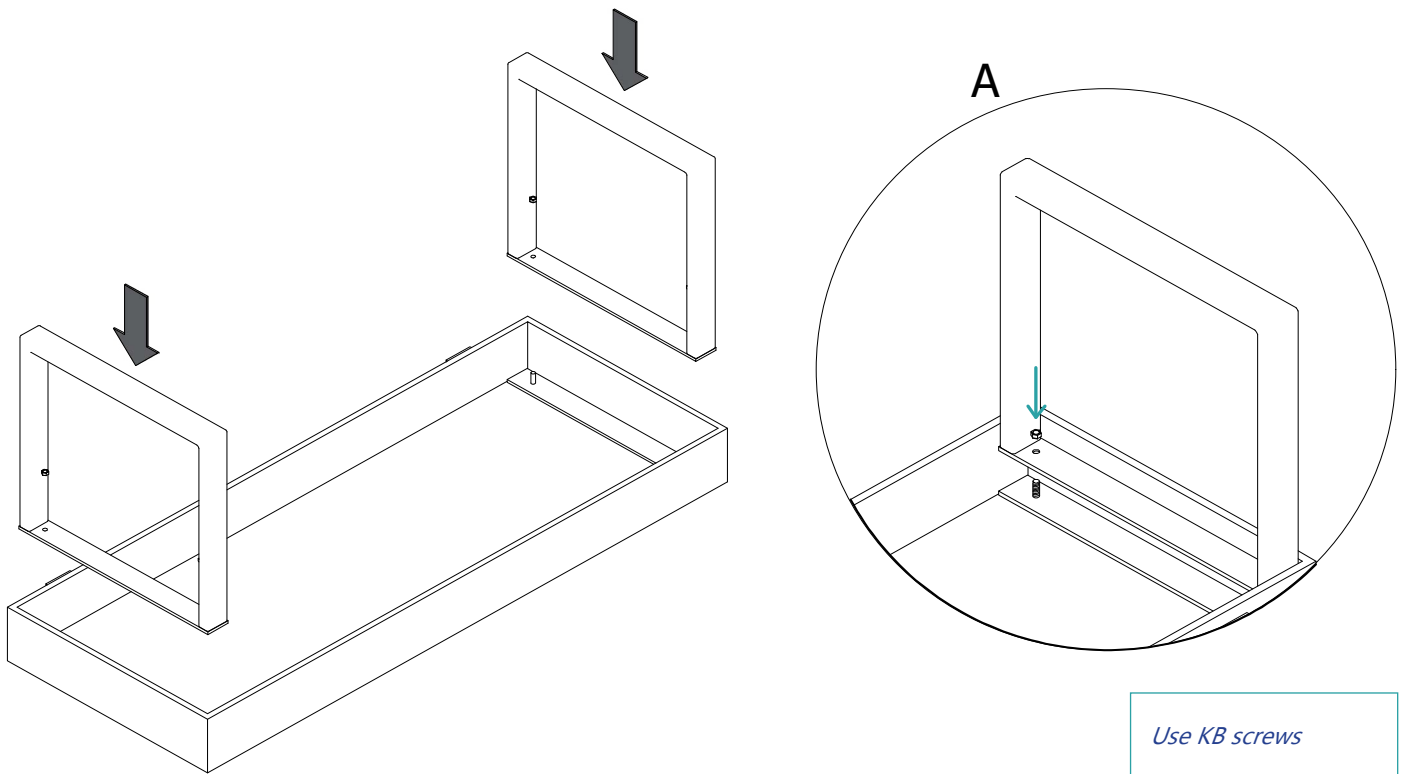

Place the benches inside the steam bath (bench must be centered in space).
If necessary, adjust the feet.

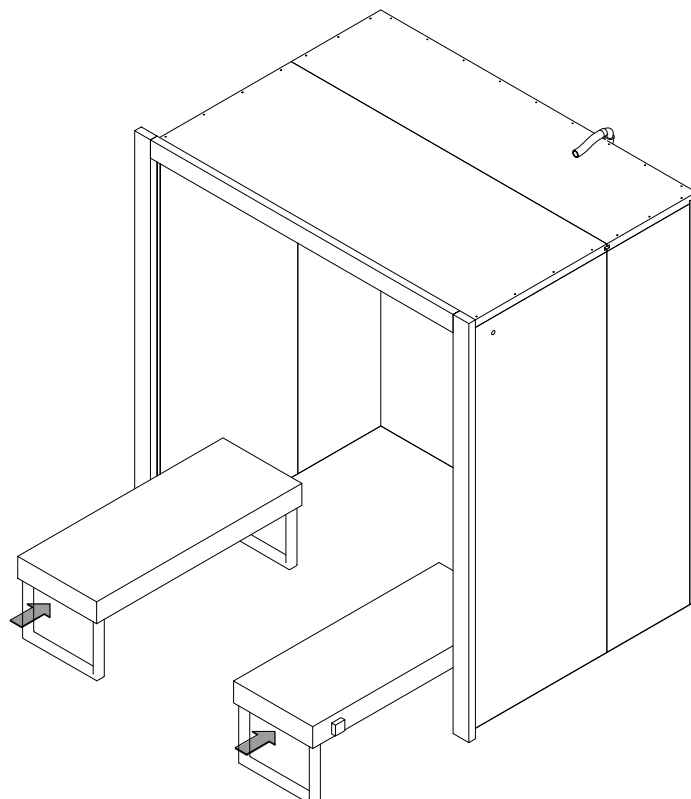

TYPE 3

The solid surface benches must be assembled by screwing the two legs to the seat with the screws supplied.

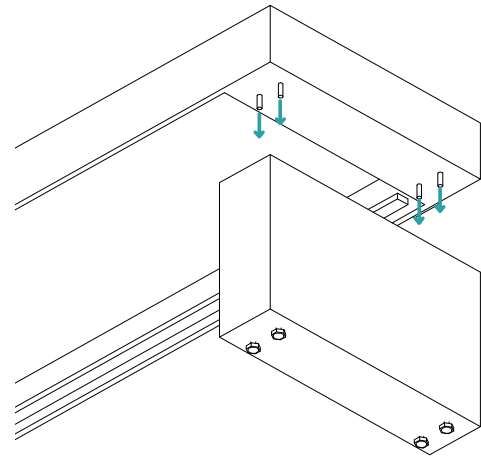
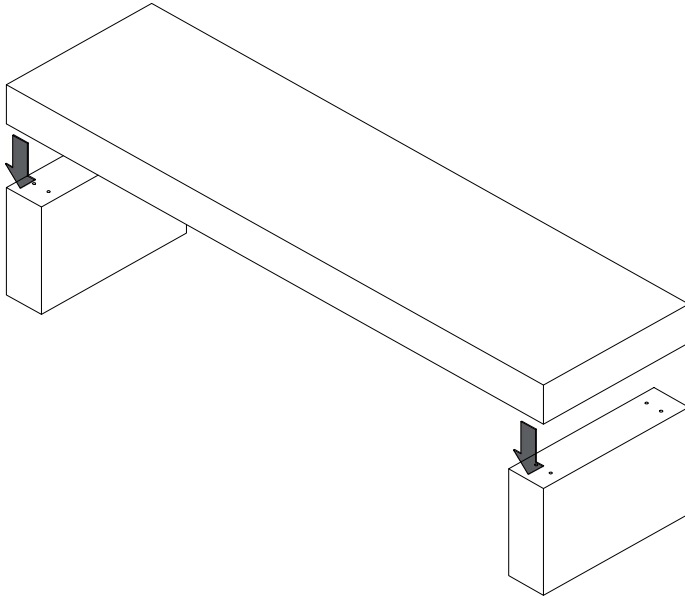

Use GB screws

Place the benches inside the steam bath (bench must be centered in space).
If necessary, adjust the feet.

Solid surface benches can be angular. Assemble the legs as described on the previous page and then screw them together with the screws provided.

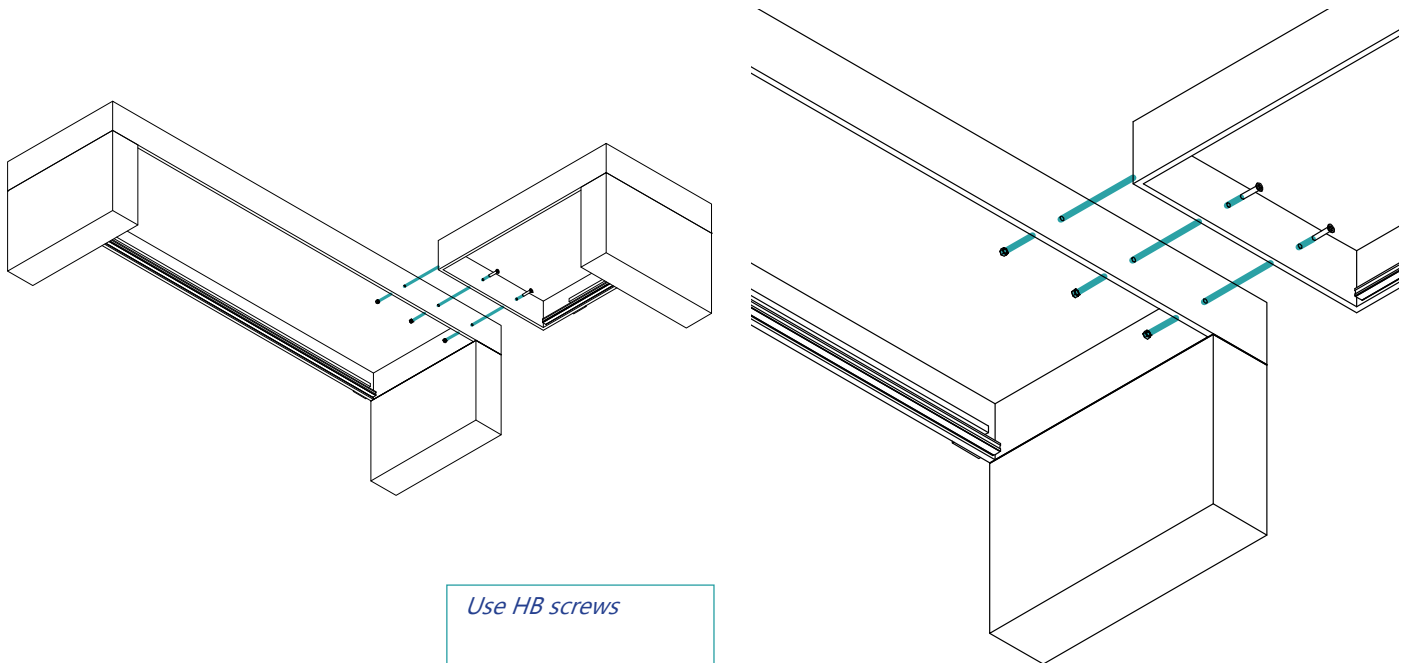

*Place the benches inside the steam bath (bench must be centered in space).
If necessary, adjust the feet.*

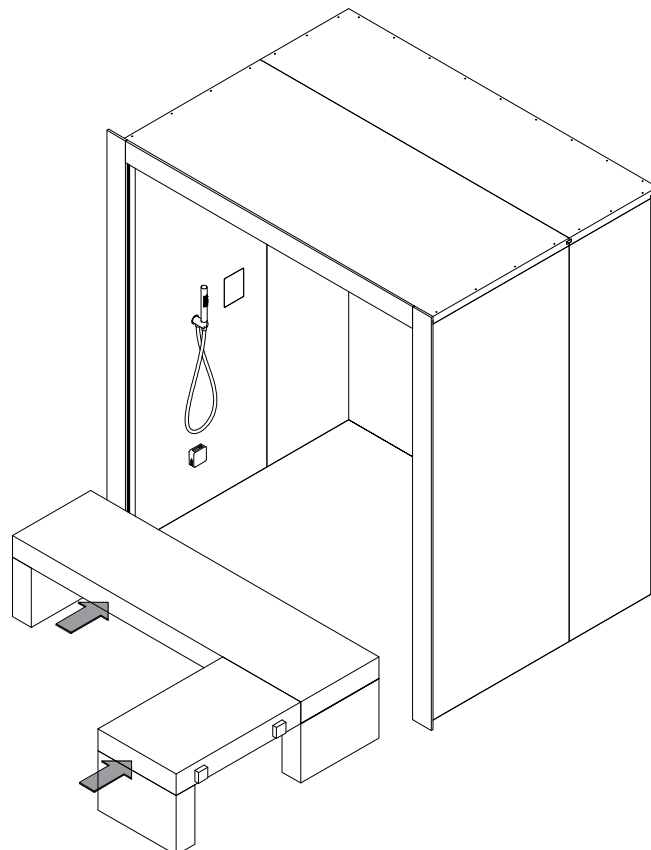

13. MONTAGGIO VETRI FISSI - FIXED GLASSES ASSEMBLY

A. WITH PET FRAME

Glue the aluminum U-profiles to the floor. the profile must be inserted in the vertical profile of the frame, see detail A. The position of the aluminum U is in the center of the vertical profile.

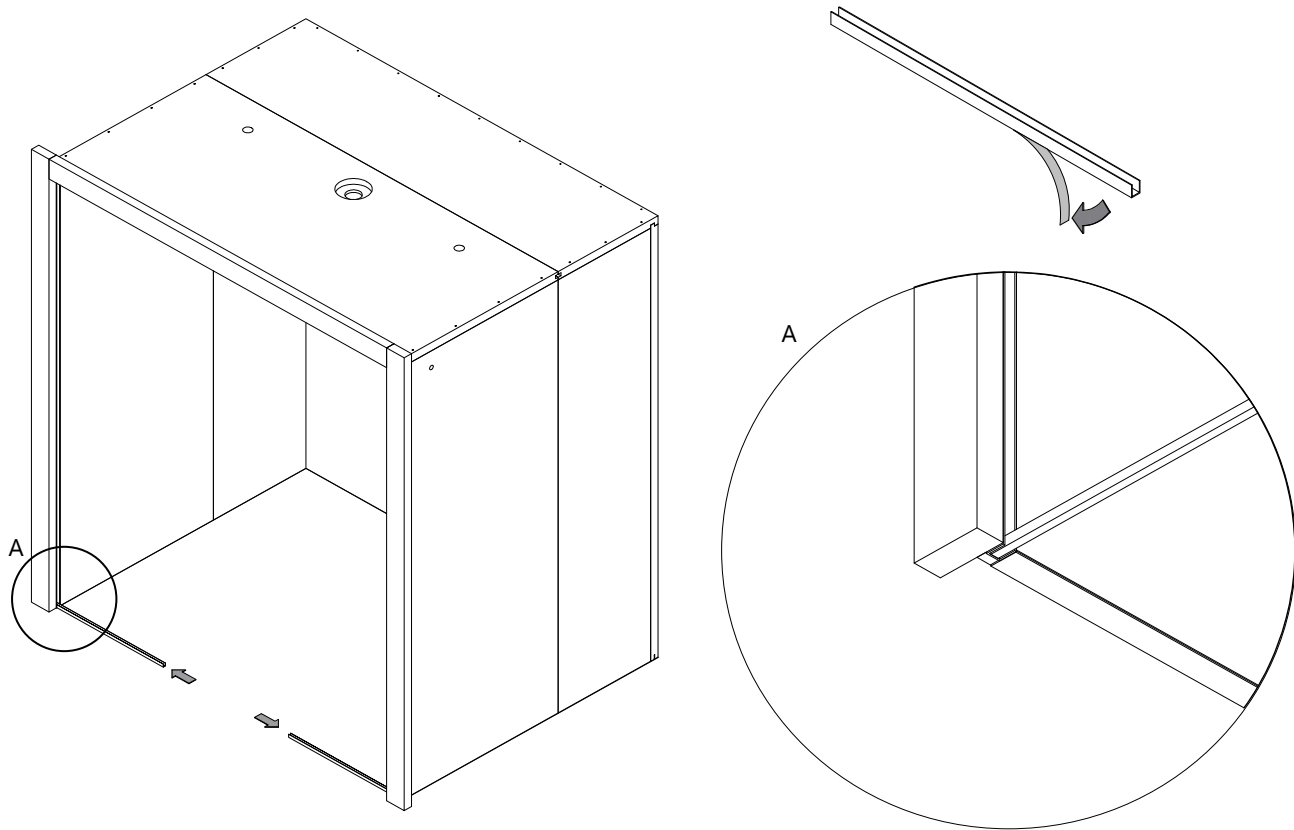

Then insert the black plastic spacers on the horizontal profile, positioning them about 100 mm from the two ends.

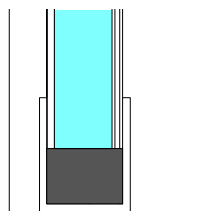

PET frame

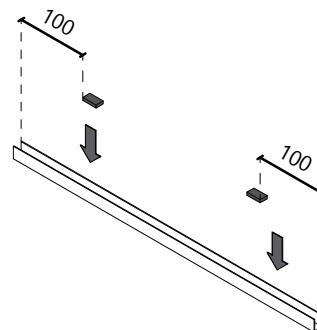

Place the glasses.

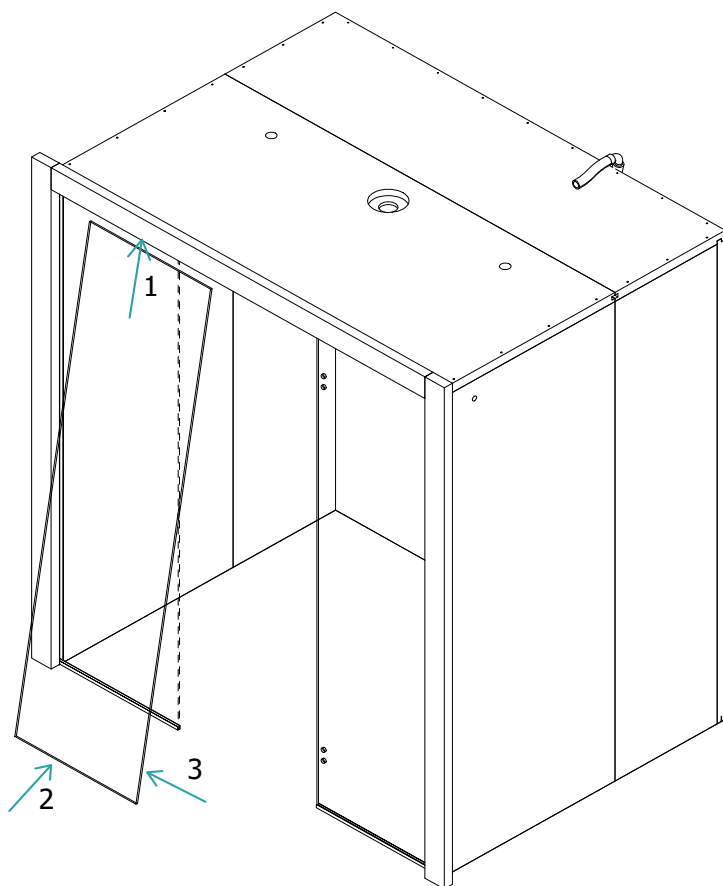

Insert the Corian glass stop spacer and screw it on with the screws provided.

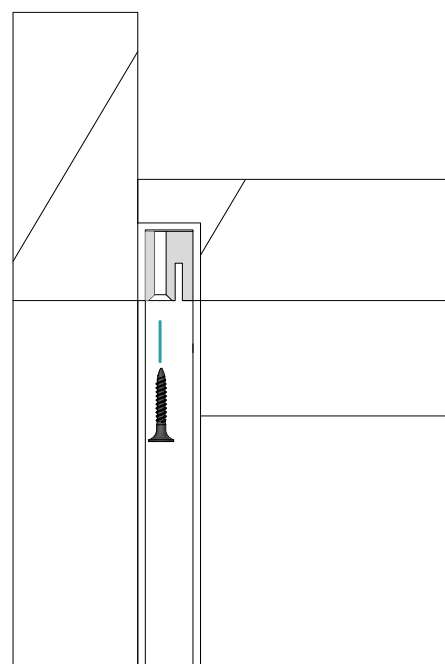
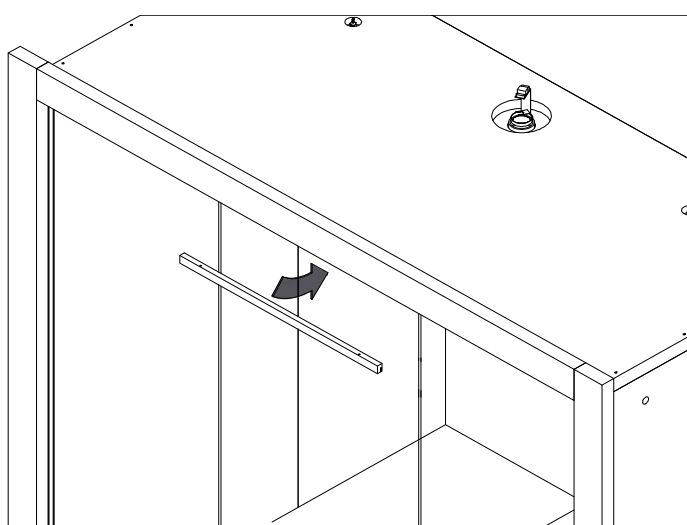

B. WITH PET FRAME (ANGULAR)

When the cabin is of the Matrix collection and angular it will be necessary, after installing the side glass, to support the cantilevered corner of the cabin. Screw the plastic screw into the hole until the ceiling is level. Be careful not to force the screw!

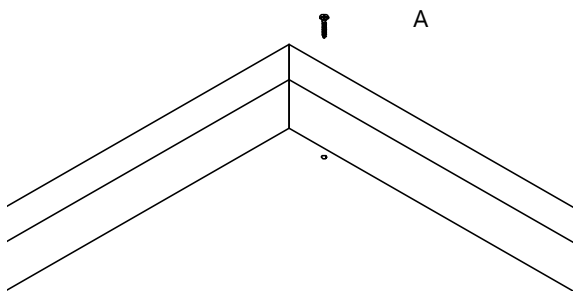
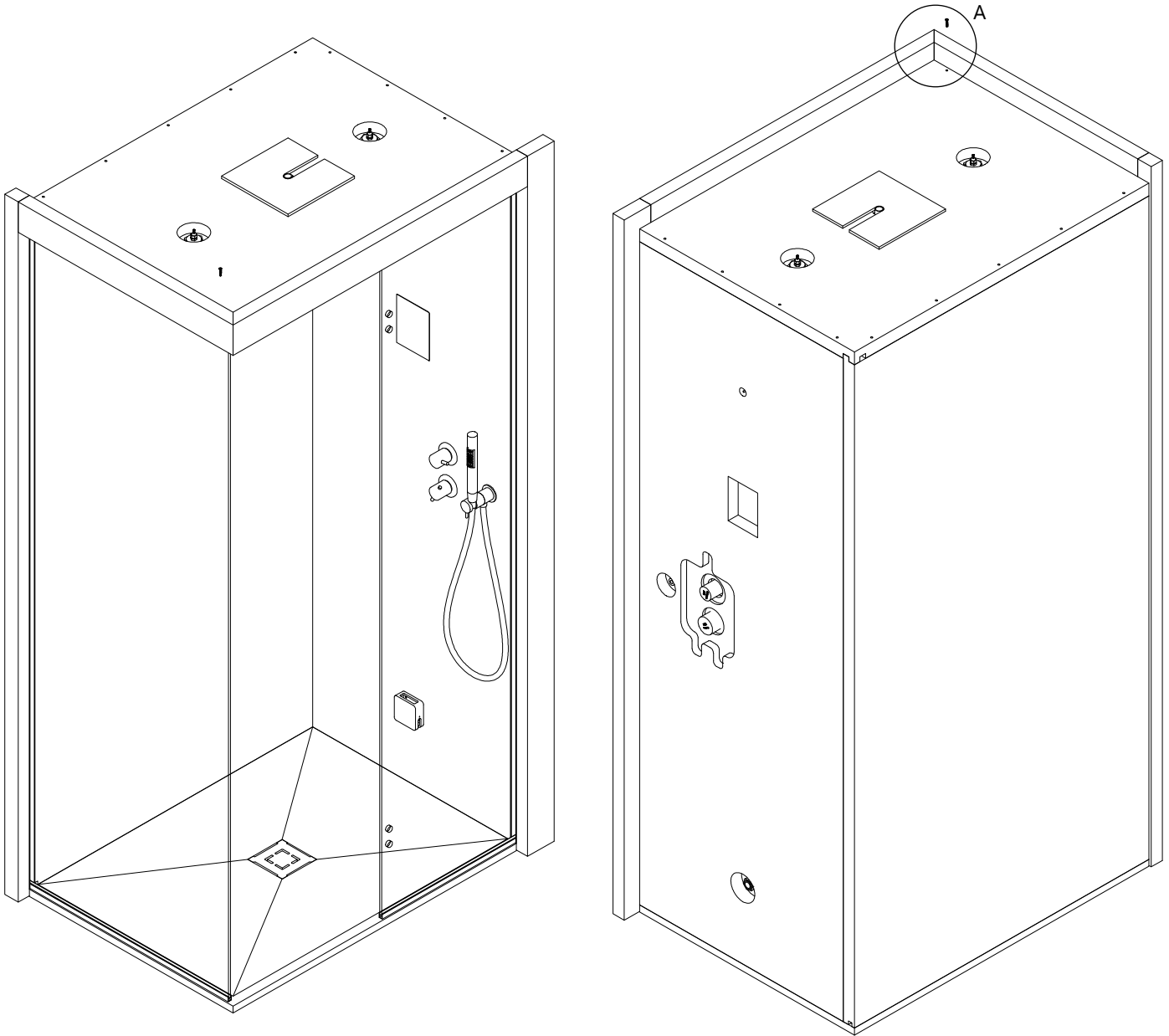

Support the cantilevered corner of the cabin.

C. WITH ALUMINUM FRAME

Glue the aluminum U-profiles to the floor.

The position of the aluminum U is 4mm from the outer side of the aluminum frame.

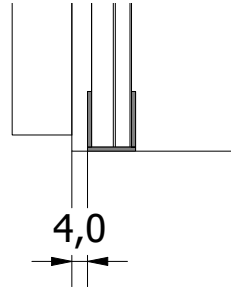
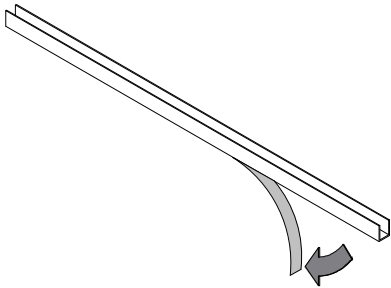

Aluminum frame

Then insert the yellow plastic spacers on the horizontal profile, positioning them about 100 mm from the two ends.

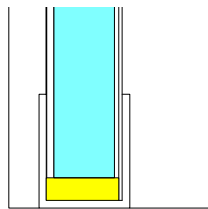

Aluminum frame

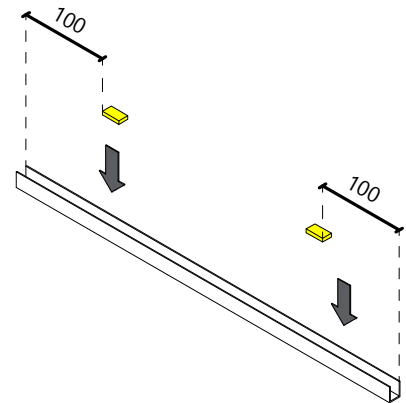

Place the glasses and fix the horizontal aluminum glass beads (A). Insert the Corian element and screw it with the screws provided.

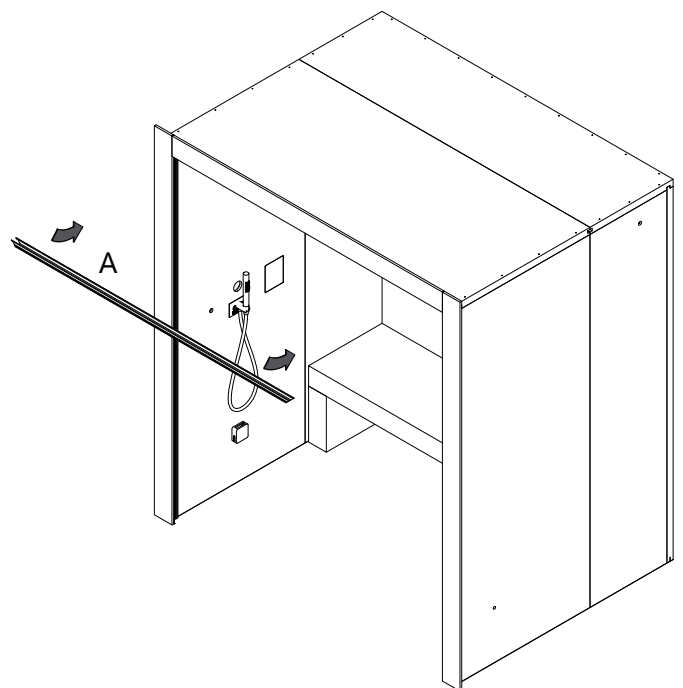
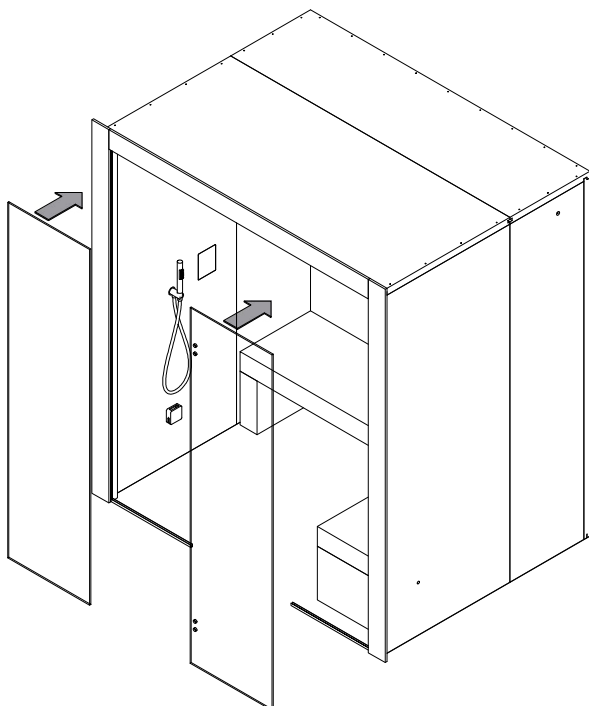

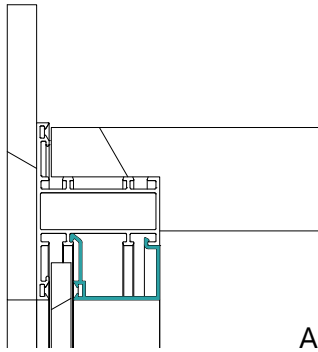

Upper aluminum glazing bead

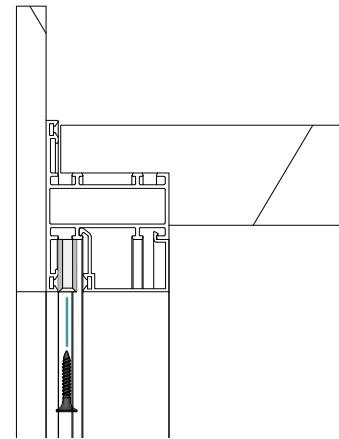
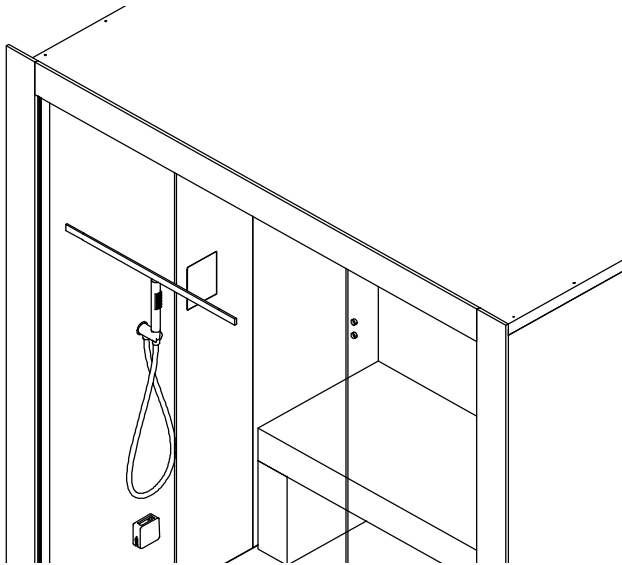

Fix the vertical aluminum glass beads (B).

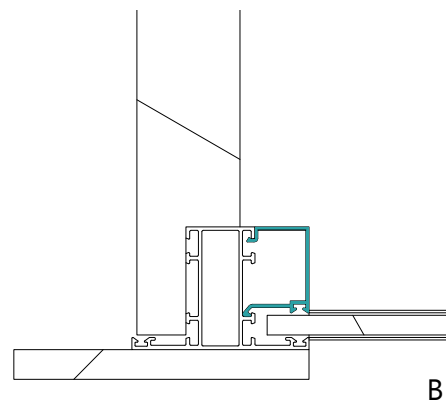
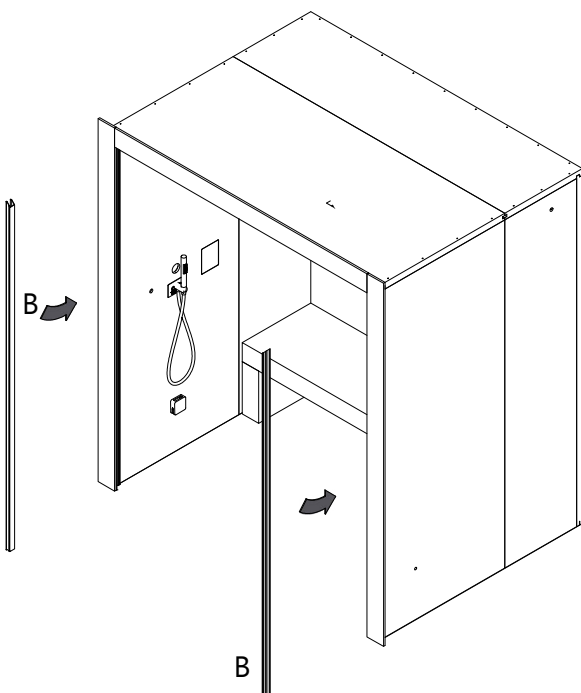

Vertical aluminum glazing bead

14. DAM PROFILE ASSEMBLY

After assembling the U-shaped profiles and the fixed glass, you can proceed with gluing the dam profile.

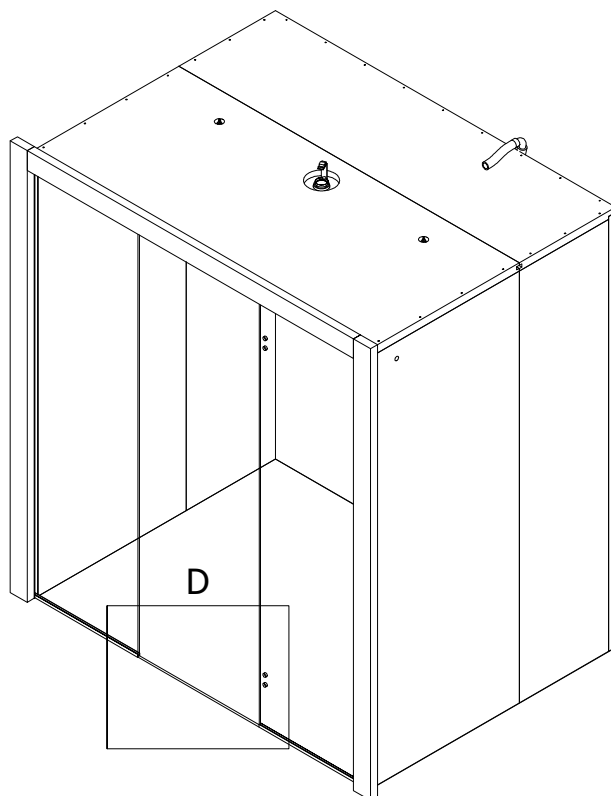
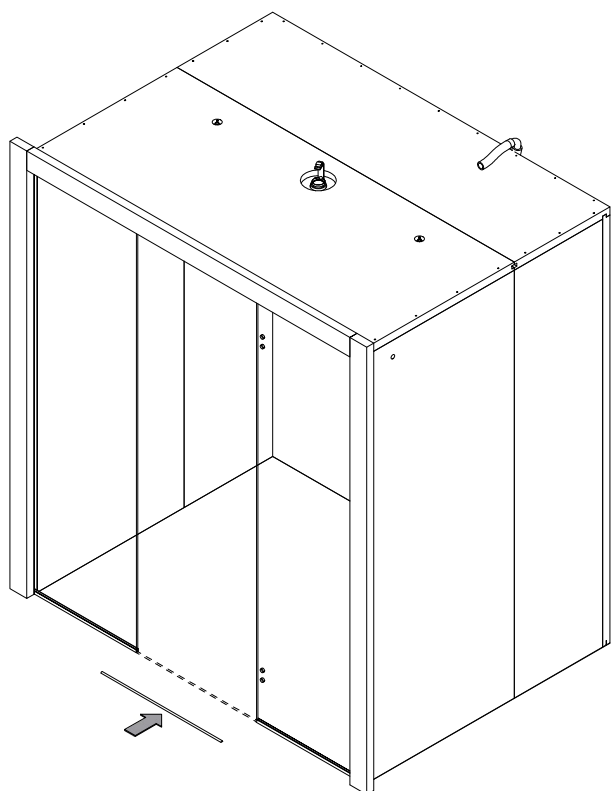

Glue the dam profile with silicone.

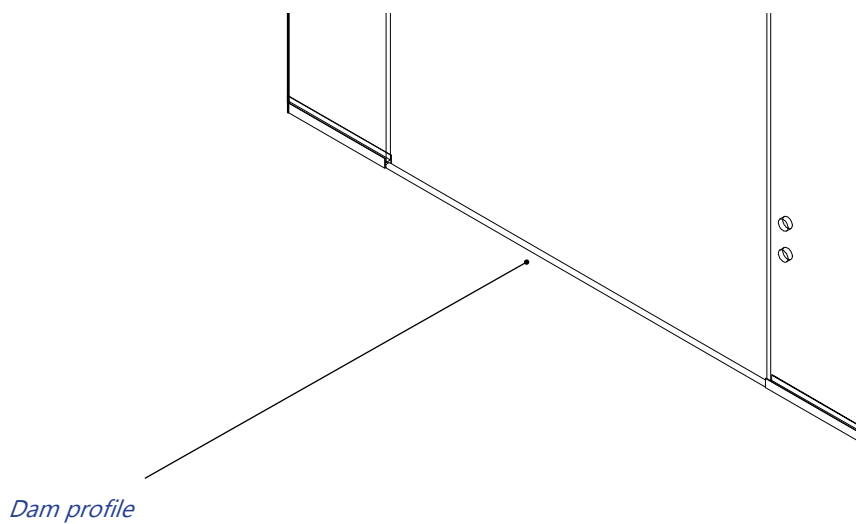

15. FINAL SEALING

*Spread a continuous bead of silicone along the entire U-shaped profile (glass profile) and also seal the dam profile well.
Attention! seal well the point of union between the U-shaped profile of the glass and the vertical profile.*

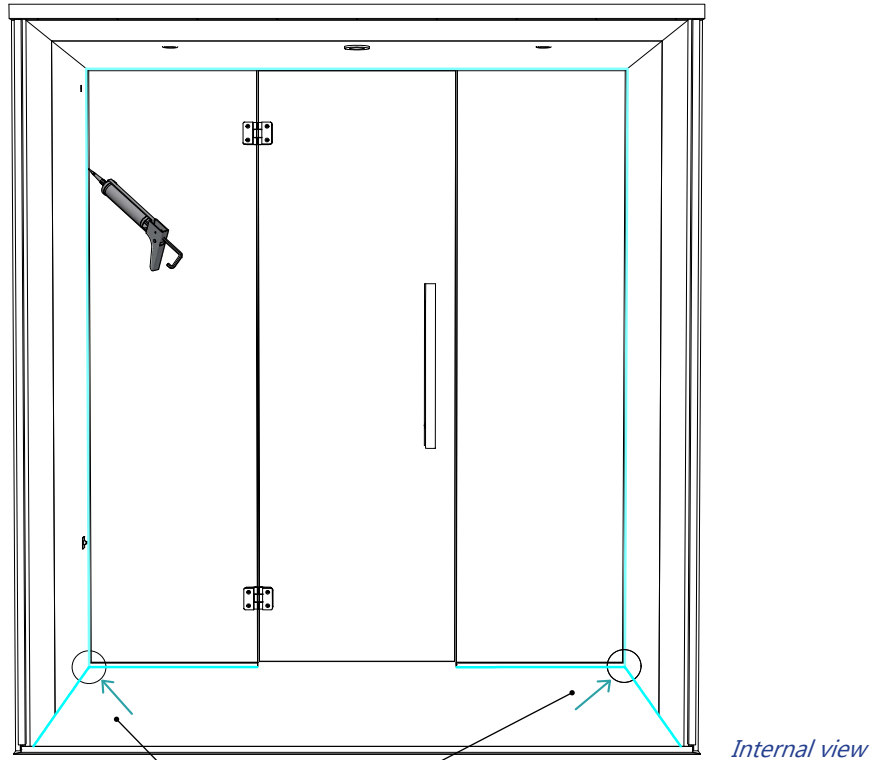

Attention!!! Seal well the point of union between the U-shaped profile of the glass and the vertical profile.

16. DOOR ASSEMBLY

Open the hinges at 90°. Mount the hinges first on the fixed glass and then on the door.

Insert the pins of the hinge into the holes in the fixed glass, placing the gasket between the glass and the metal, insert the eccentrics (fig. A) all in the same position, check with a spirit level that the hinge is horizontal. Position the second gasket and the closing plate, fix everything with the screws.

Proceed with the assembly of the second hinge on the fixed glass. Fit the glass door by positioning it at 90° with respect to the fixed glass and inserting the hinges, gaskets and eccentrics.

If the door needs adjustment, turn the eccentrics (fig. B).

NB: THE PART OF THE HINGES MOUNTES ON THE FIXED GLASS IS THE LARGER PART WITH THE FIXED CENTRAL PIN.

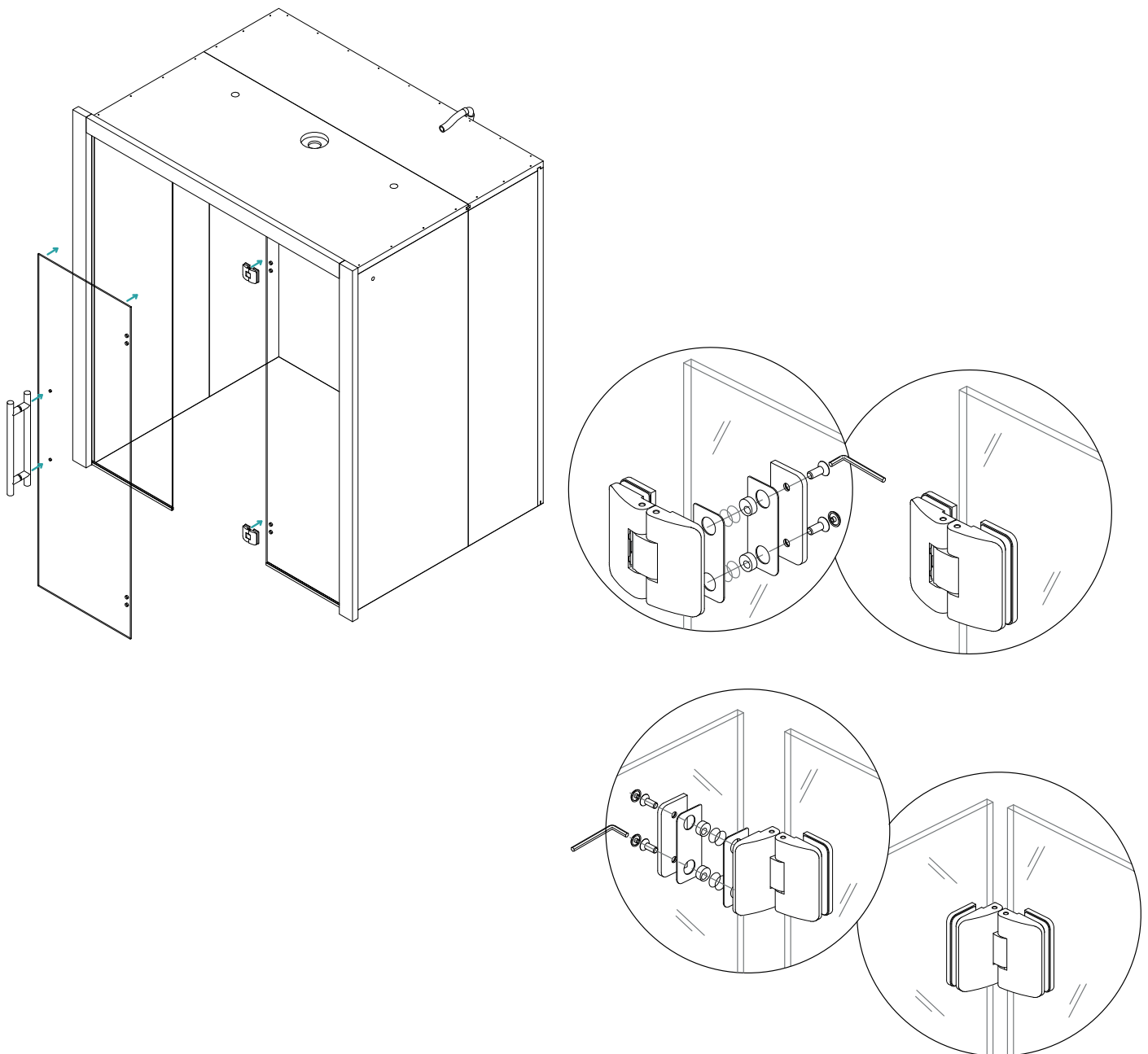

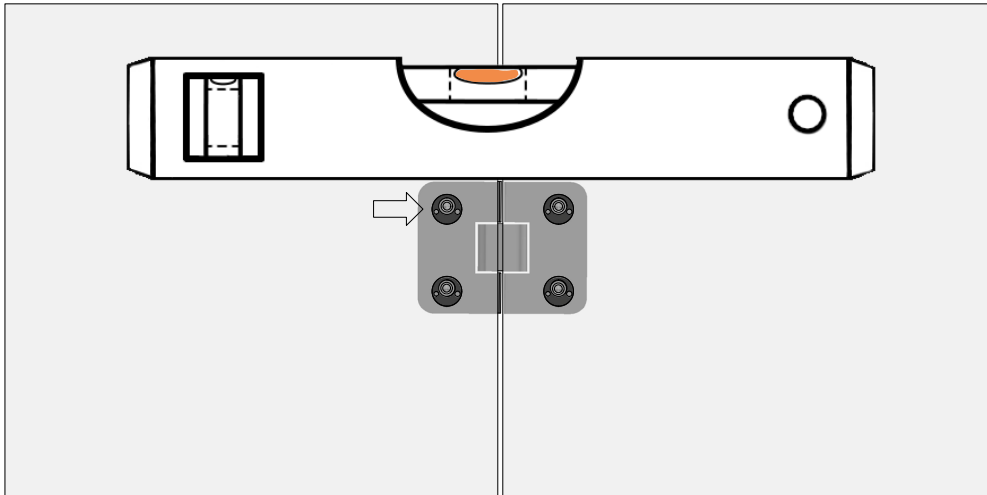

FIG. A

After inserting all eccentrics, check that the hinges are level. (fig. A)

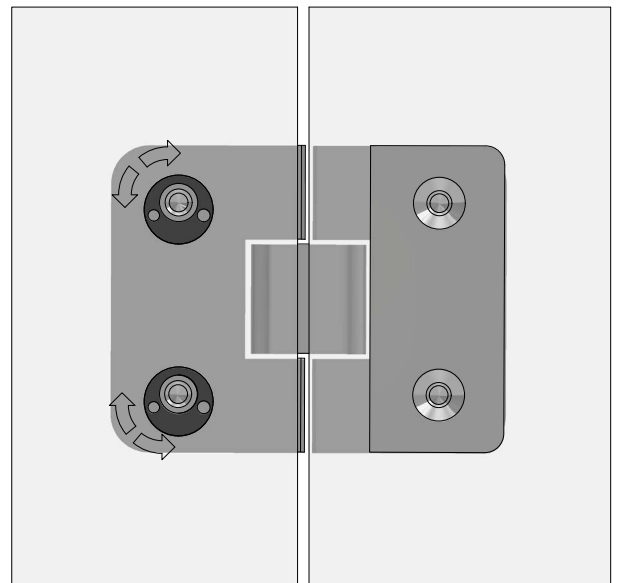
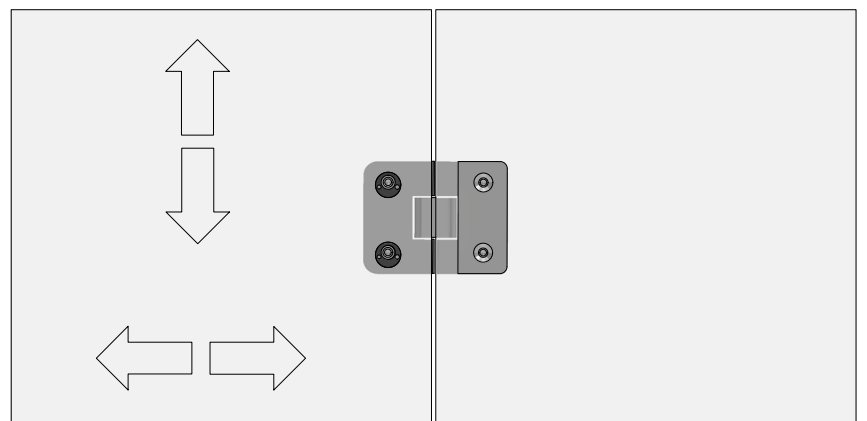
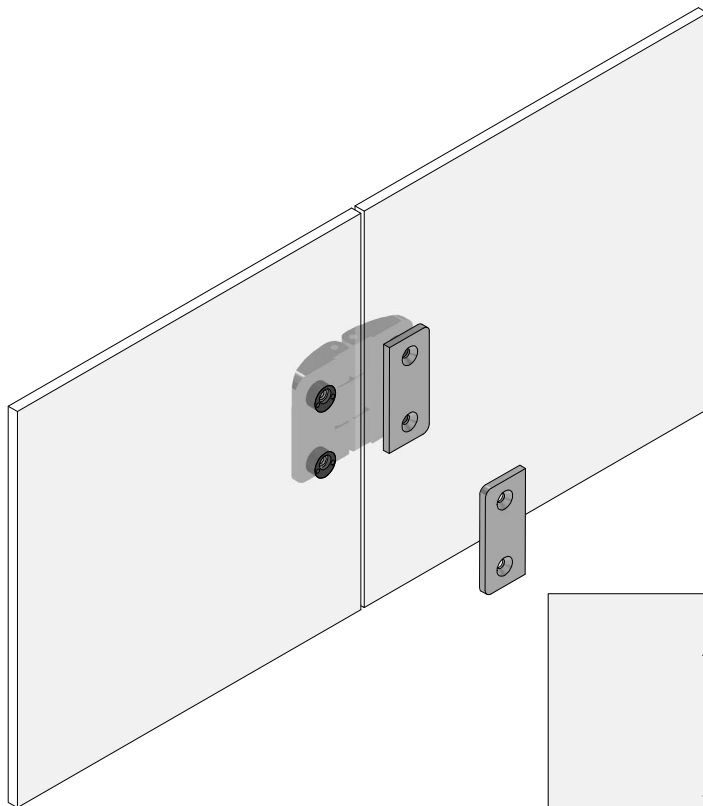

FIG. B

If the door needs adjustment, turn the eccentrics (fig. B).



17. HANDLES ASSEMBLY

The handles are of two types.

TYPE 1



TYPE 2



TYPE 1

Assemble the handle starting from the half inside the cabin. On the external side of the glass put the steel support fixed with screws on the handle. Use the transparent seal inserted between glass metal objects. Assemble the external part of the handle fixing on the steel support from the top and from the bottom.

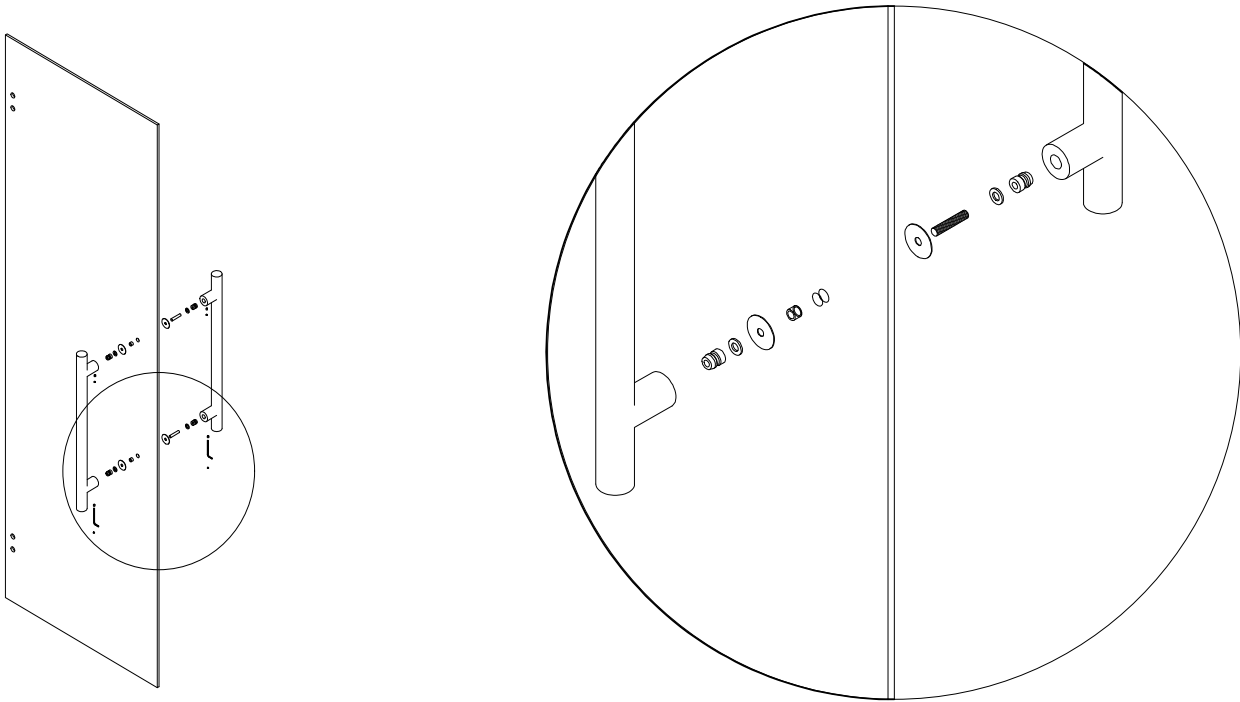

TYPE 2

Assemble the handle starting from the cabin. On the external side of the glass put the steel support fixed with screws on the handle. Use the transparent seal inserted between glass metal objects. Assemble the external part of the handle fixing on the steel support from the top and from the bottom.

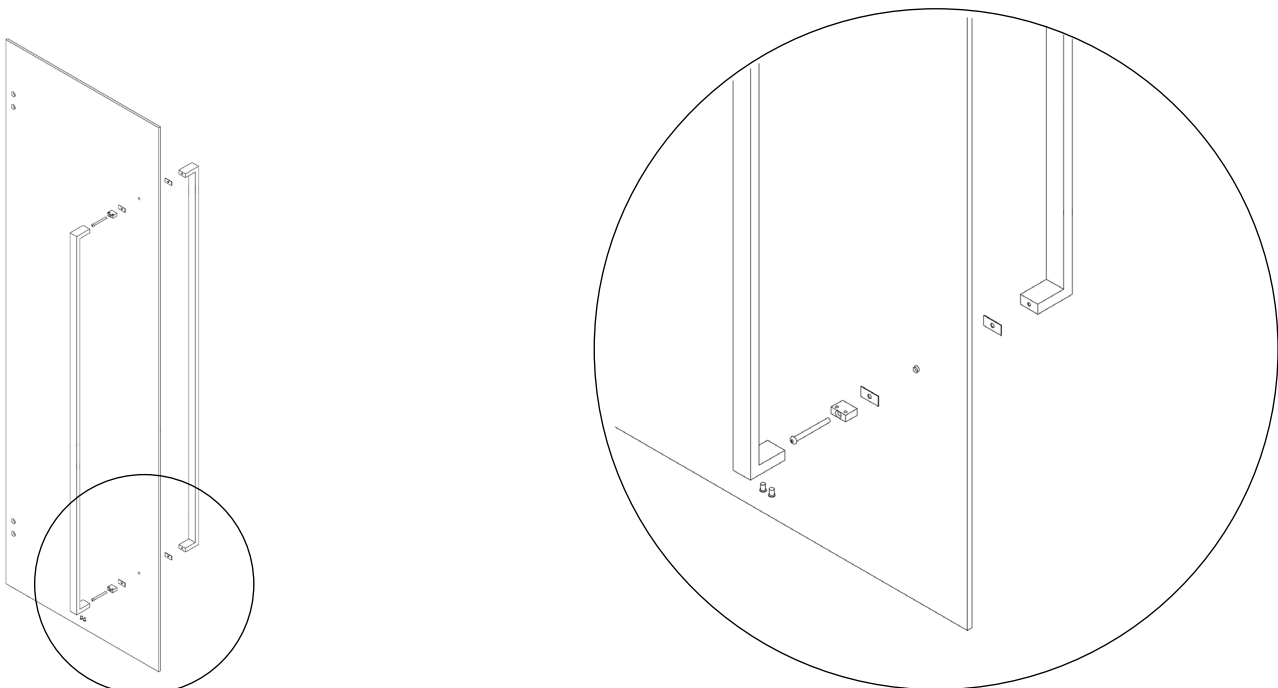

18. GASKETS ASSEMBLY

Fit the gaskets indicated along the entire length of the glass, check that the door is perfectly closed.

Vertical gasket between door and fixed glass. (both on the stop side and on the hinge side)

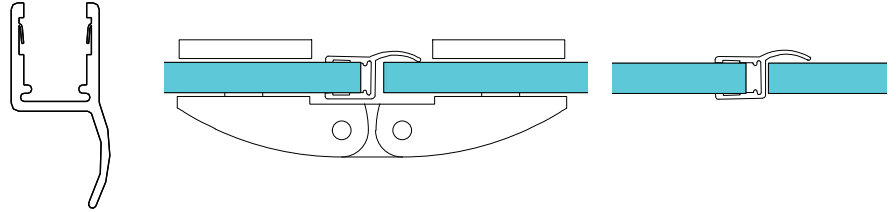

Horizontal gasket placed between the Corian element and the frame

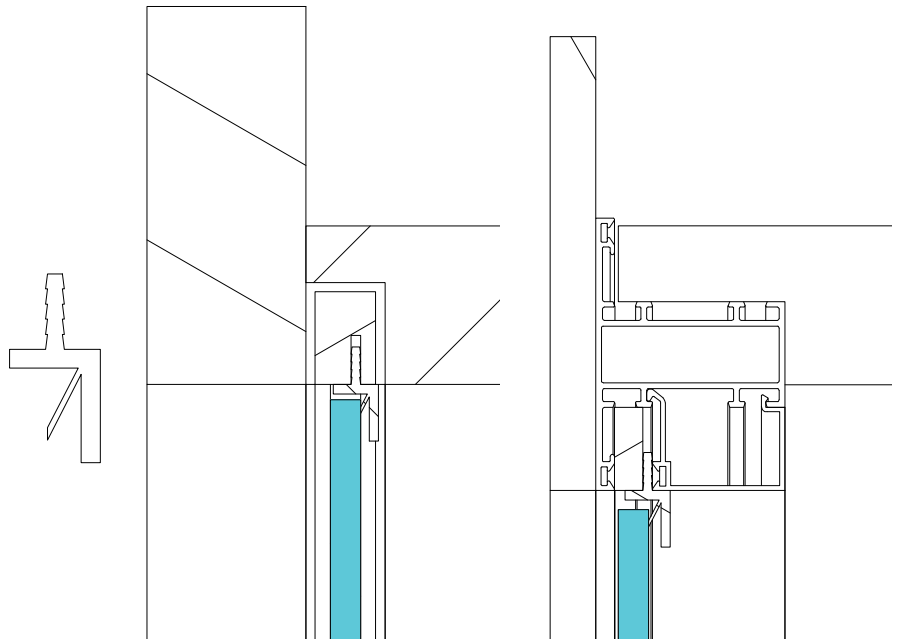

Vertical gasket between door and fixed glass. (magnetic)

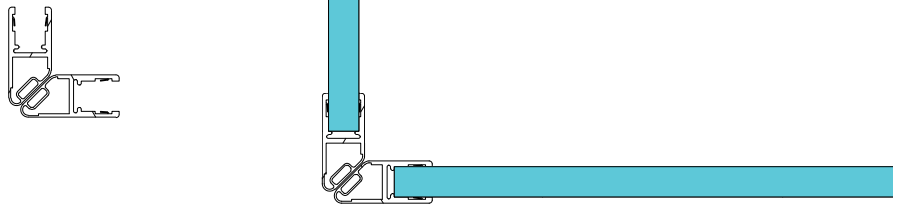

Horizontal seal for lower door edge.

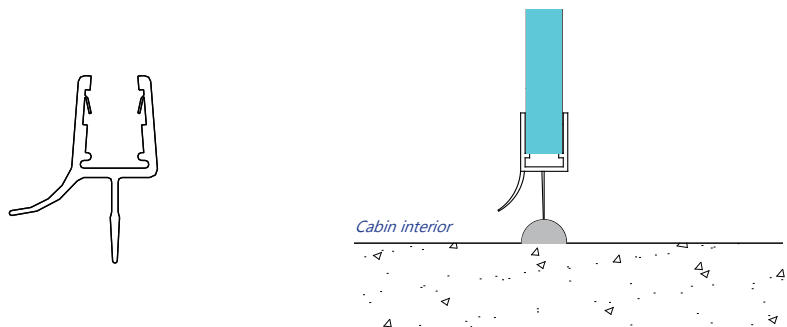

19. BONDING AND SEALING

WALL/CORNER WALL JUNCTION

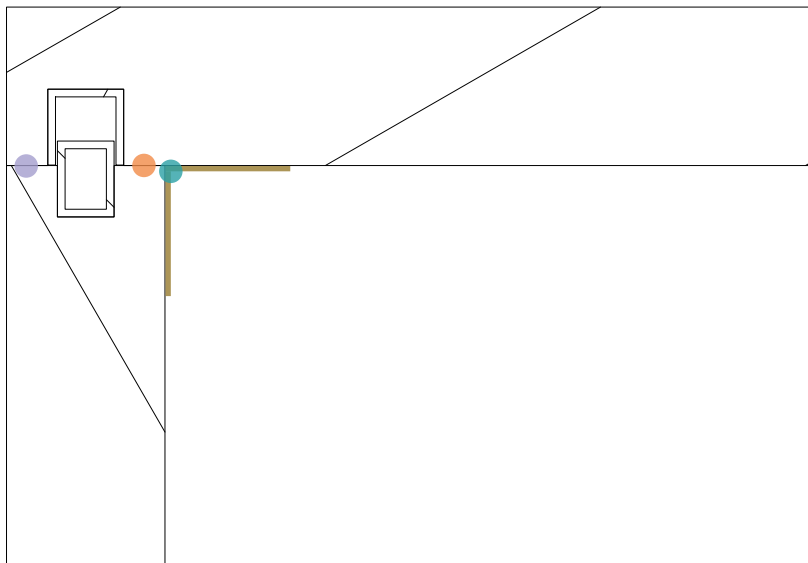

● One-component polyurethane adhesive
POWERFLEX

● Wurth BOND-SEAL

● Wurth BOND-SEAL (colored cabins)
SIKA POOL (white cabins)

— Apply strips of paper tape to protect the panel from glue leaking

WALL/WALL JUNCTION

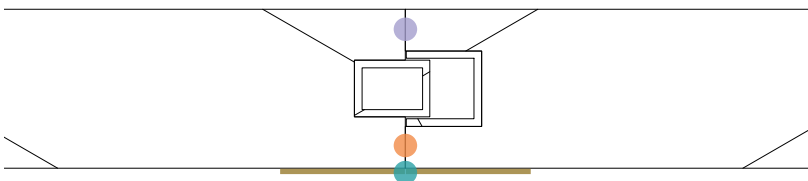

● One-component polyurethane adhesive
POWERFLEX

● Wurth BOND-SEAL

● Wurth BOND-SEAL (colored cabins)
SIKA POOL (white cabins)

— Apply strips of paper tape to protect the panel from glue leaking

EILING/CEILING JUNCTION

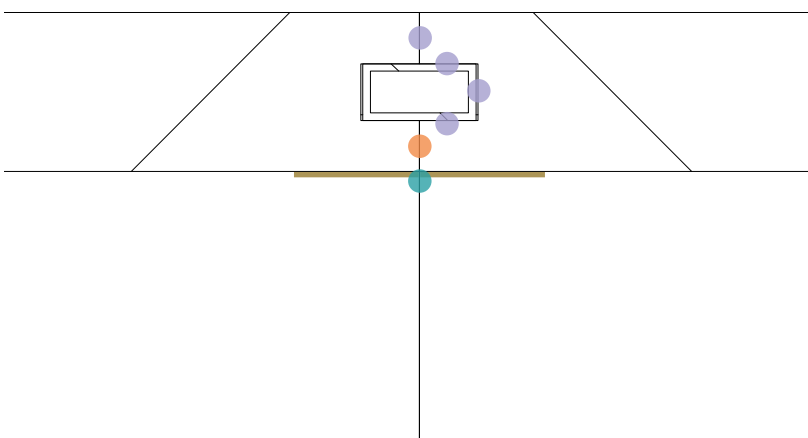

● One-component polyurethane adhesive
POWERFLEX

● Wurth BOND-SEAL

● Wurth BOND-SEAL (colored cabins)
SIKA POOL (white cabins)

— Apply strips of paper tape to protect the panel from glue leaking

CEILING/WALL JUNCTION

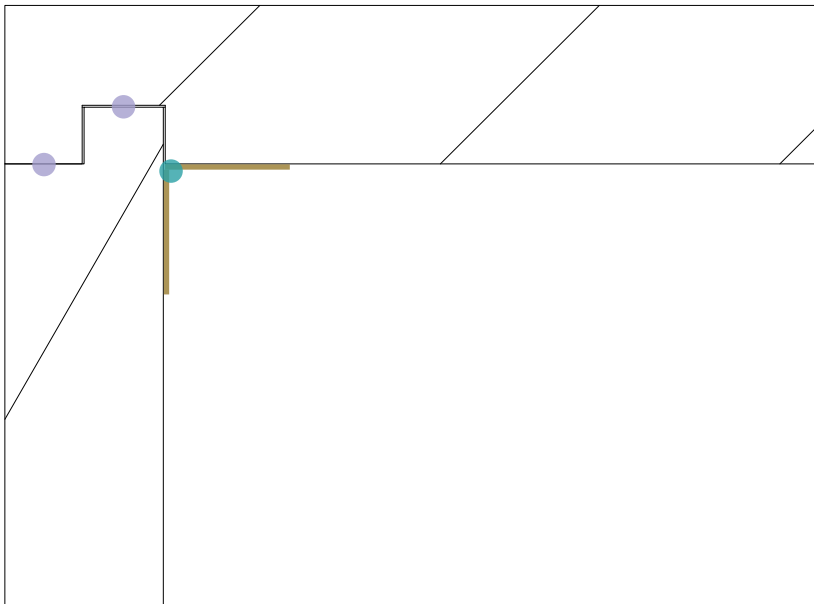

● One-component polyurethane adhesive
POWERFLEX

● Wurth BOND-SEAL (colored cabins)
SIKA POOL (white cabins)

● Apply strips of paper tape to protect the
panel from glue leaking

WALL/FLOOR JUNCTION

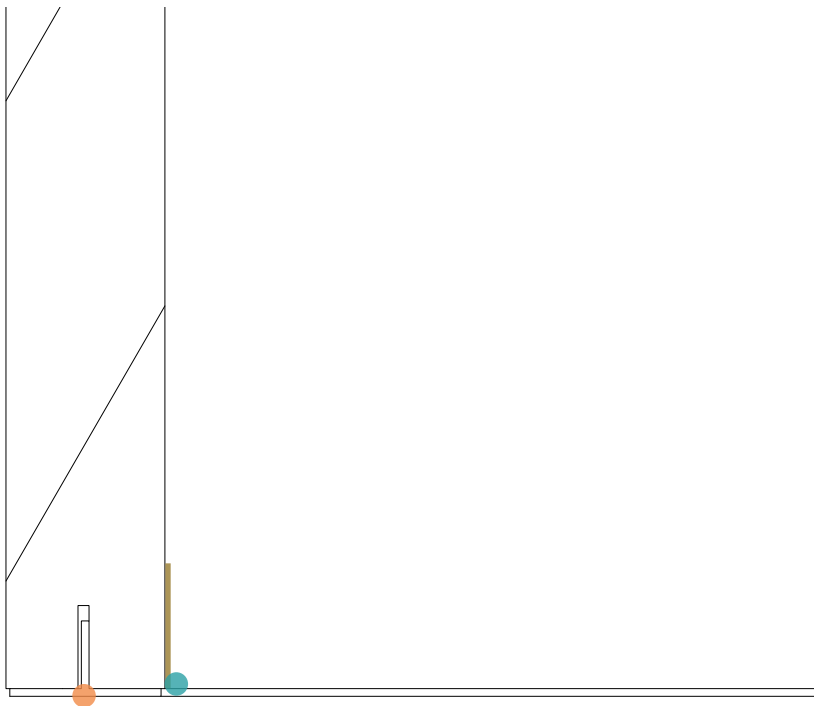

● Wurth BOND-SEAL

● Wurth BOND-SEAL (colored cabins)
SIKA POOL (white cabins)

● Apply strips of paper tape to protect the
panel from glue leaking

20. OPTIONAL - OPTIONAL

SHOWERHEADS

The shower heads are of three types.

Type 1



Shower head 30x30 steel with rain effect.

Type 2



Shower head 2 in 1 50x50 steel with rain and waterfall effect.

Type 3

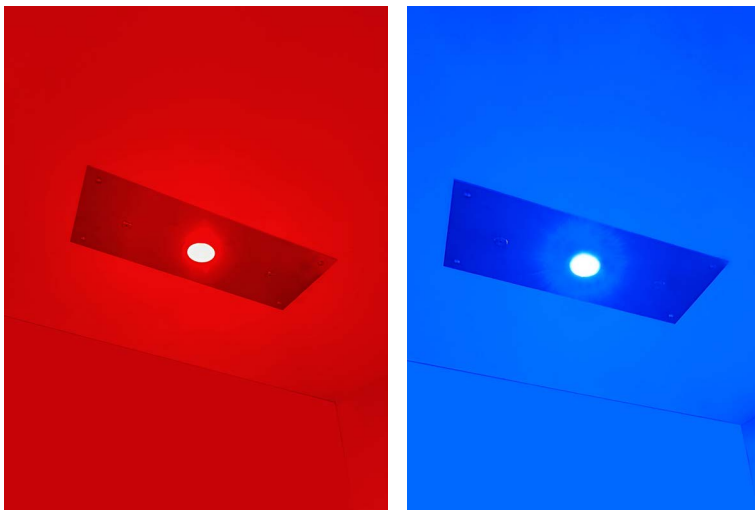

Shower head with nebulizer 30x12 water jets and chromotherapy.

Type 1

Connect the hot and cold water to the pipes coming out of the cabin wall (red-hot, blue-cold). Connect the shower head to the pipe coming out of the mixer (yellow), then mount the shower head with the appropriate screws from inside the cabin.

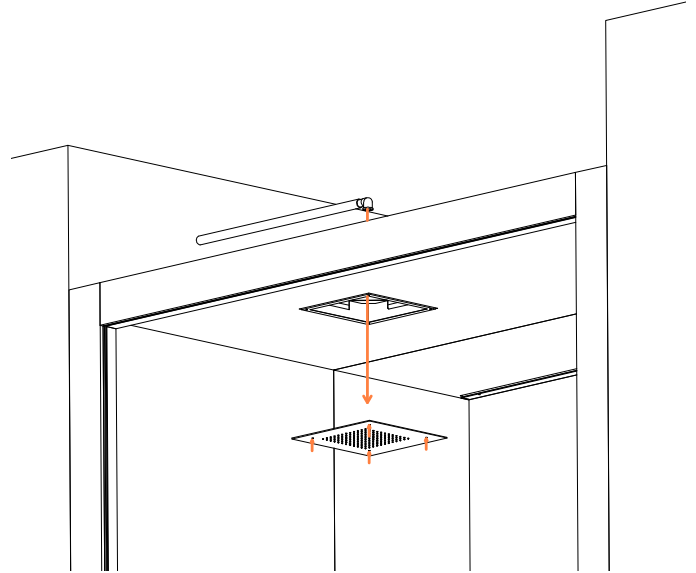
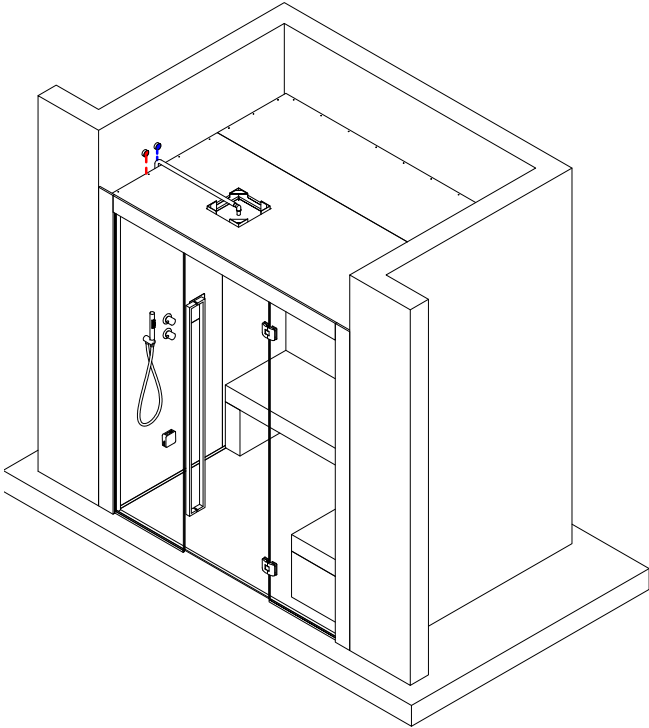

Type 2

Connect the hot and cold water to the pipes coming out of the cabin wall (red-hot, blue-cold). Connect the shower head to the pipes coming out of the mixer (yellow-rain and black-waterfall), then mount the shower head with the appropriate screws from inside the cabin.

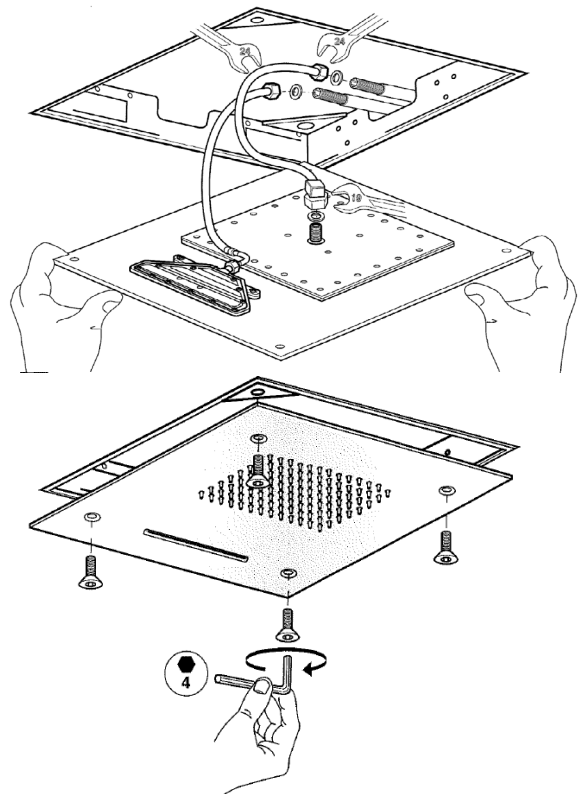
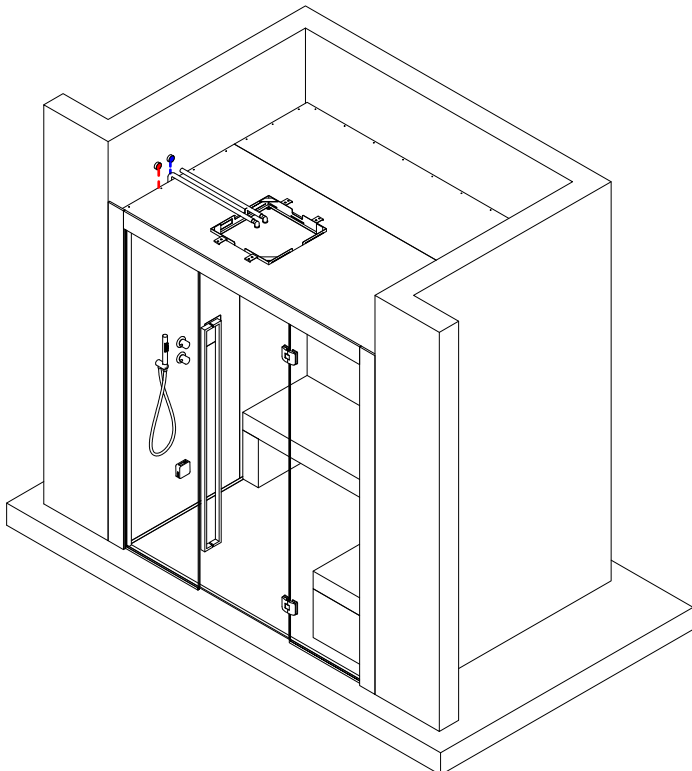

Type 3

Connect the emotional shower heads following the diagram below (aroma pump on request).

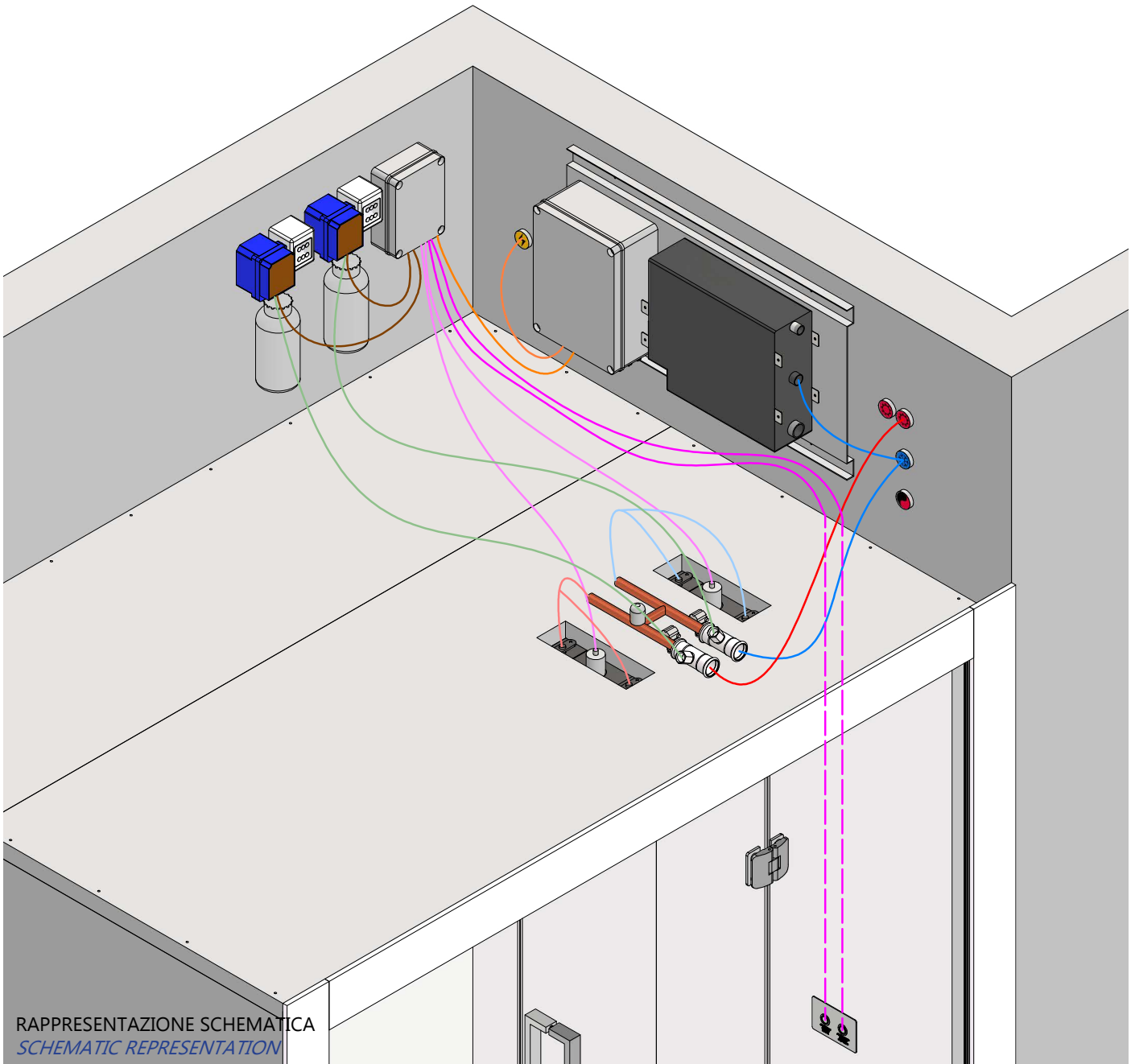

— Cold water connection to water jet

— Shower head water jet connection

— Cold water connection to water jet

— Shower head water jet connection

— Connection of aroma pipes to elements for
aroma coupling

— Connection of the shower head control unit
to the steam bath control unit

— Connection of aroma pumps to control unit

— Connection of shower head control unit to
shower heads

— Buttons control unit connection

SPOTLIGHT ASSEMBLY

Fit the spotlights and connect the cables coming from the control unit.

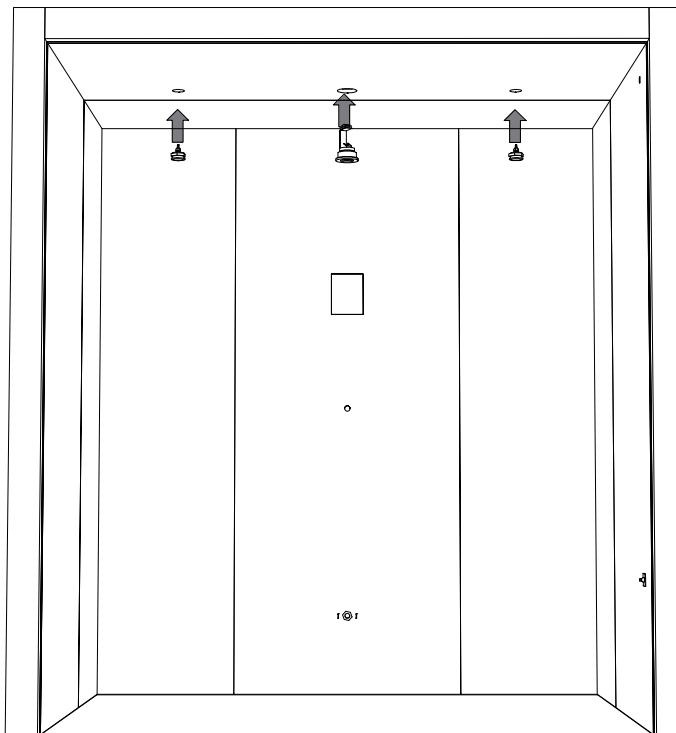

SPEAKERS

Fix the speakers above the ceiling, before mounting the ceiling on the walls, with the appropriate screws, and connect the cables to the control unit.

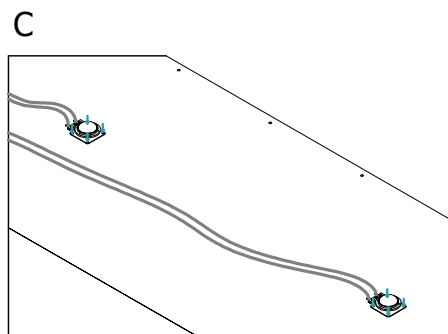
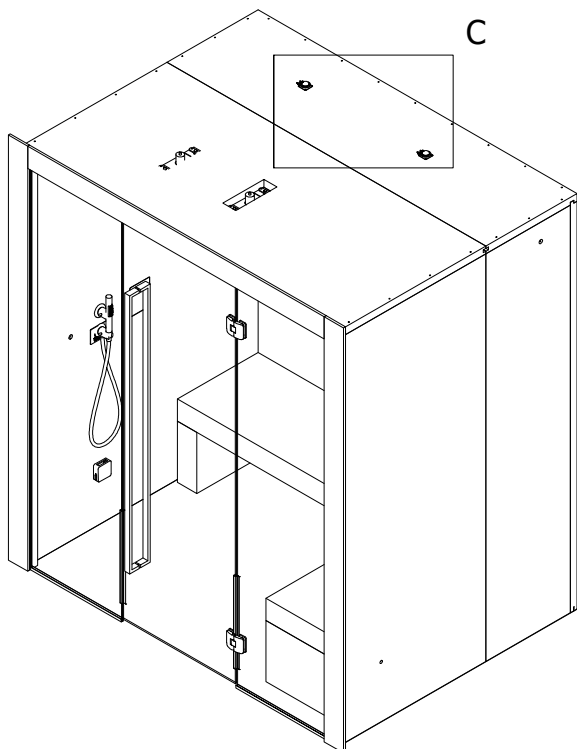

CLOUD STEAM OUTLET AIR SYSTEM

Steam cube in solid surface, with RGB spotlight.



Air steam technology

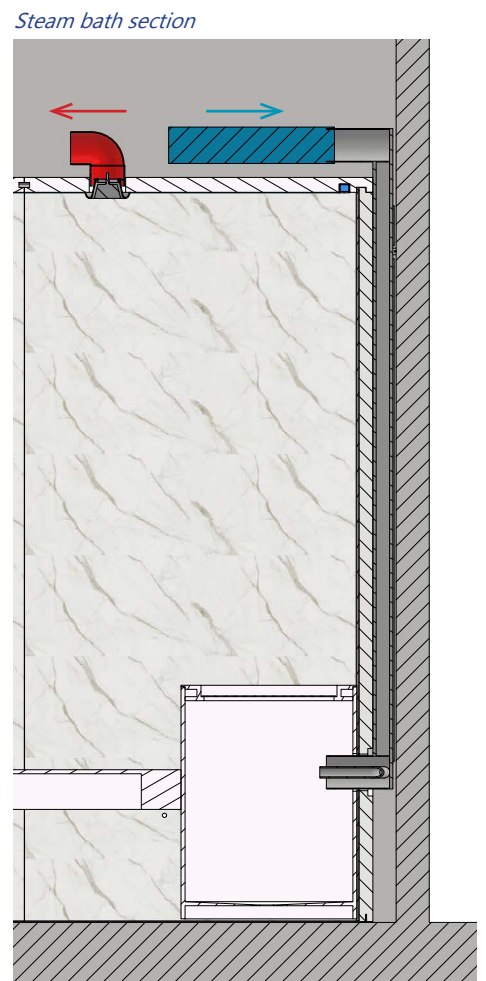
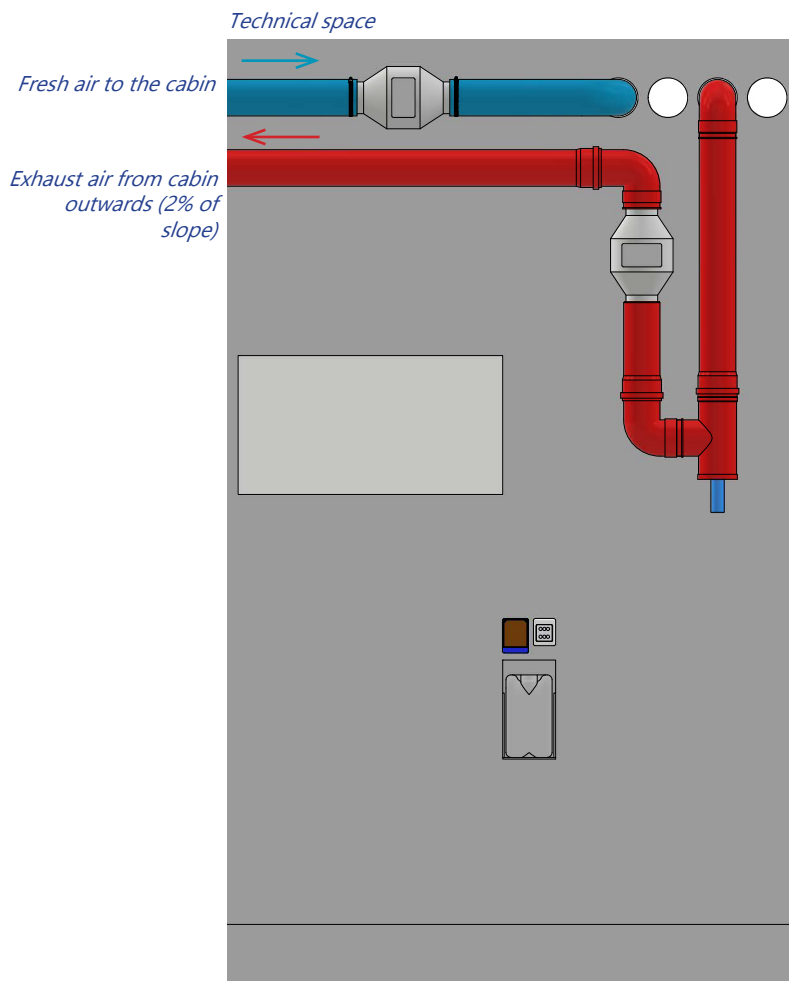

21. ELECTRICAL CONNECTIONS

In the next pages, there are some schemes for electrical connections.

With any kind of Control unit and power supply, these are the steps for the connections:

- a) Connection to the mains with a double insulated cable directly into the terminal of the control unit: Neutral to terminal N, ground cable on terminal PE phase of the L1, L2 and L3. Observe the color of the cables and the minimum section. Upstream there must be a differential switch 30mA.*
- b) Connect the cable marked ST1 and ST2 temperature sensor directly to the plug.*
- c) Connect the Earth cable from the temperature sensor straight to the Terminal board PE*
- d) Connect the keyboard cable DIS*
- e) Connect the led RGB cable LED1 and LED2*
- f) Connect the speakers (optional) cable MUS*

• 3 - 6 KW 230V 3 - 6 KW 230V

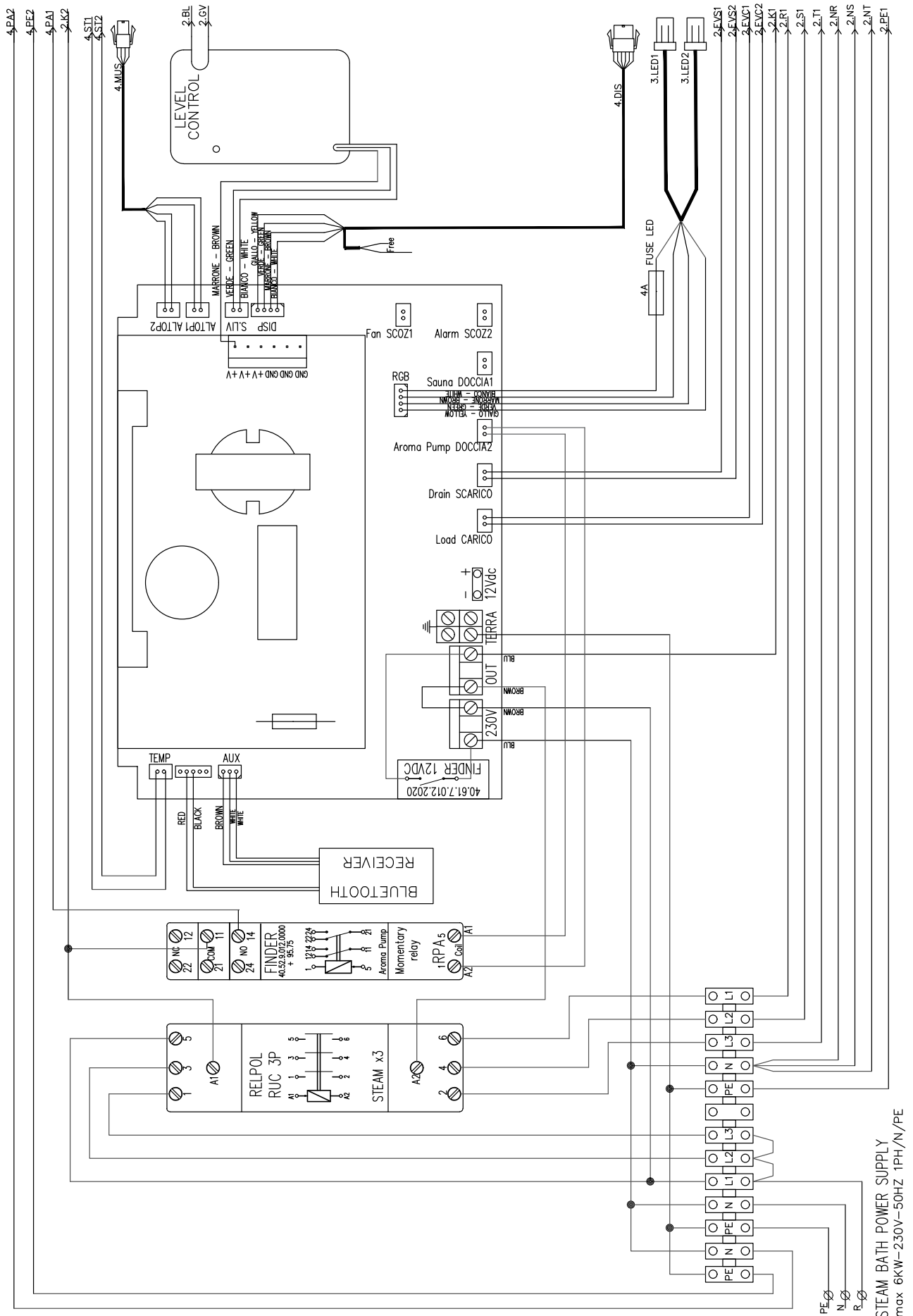

STEAM BATH POWER SUPPLY
max 6KW-230V-50HZ 1PH/N/PE

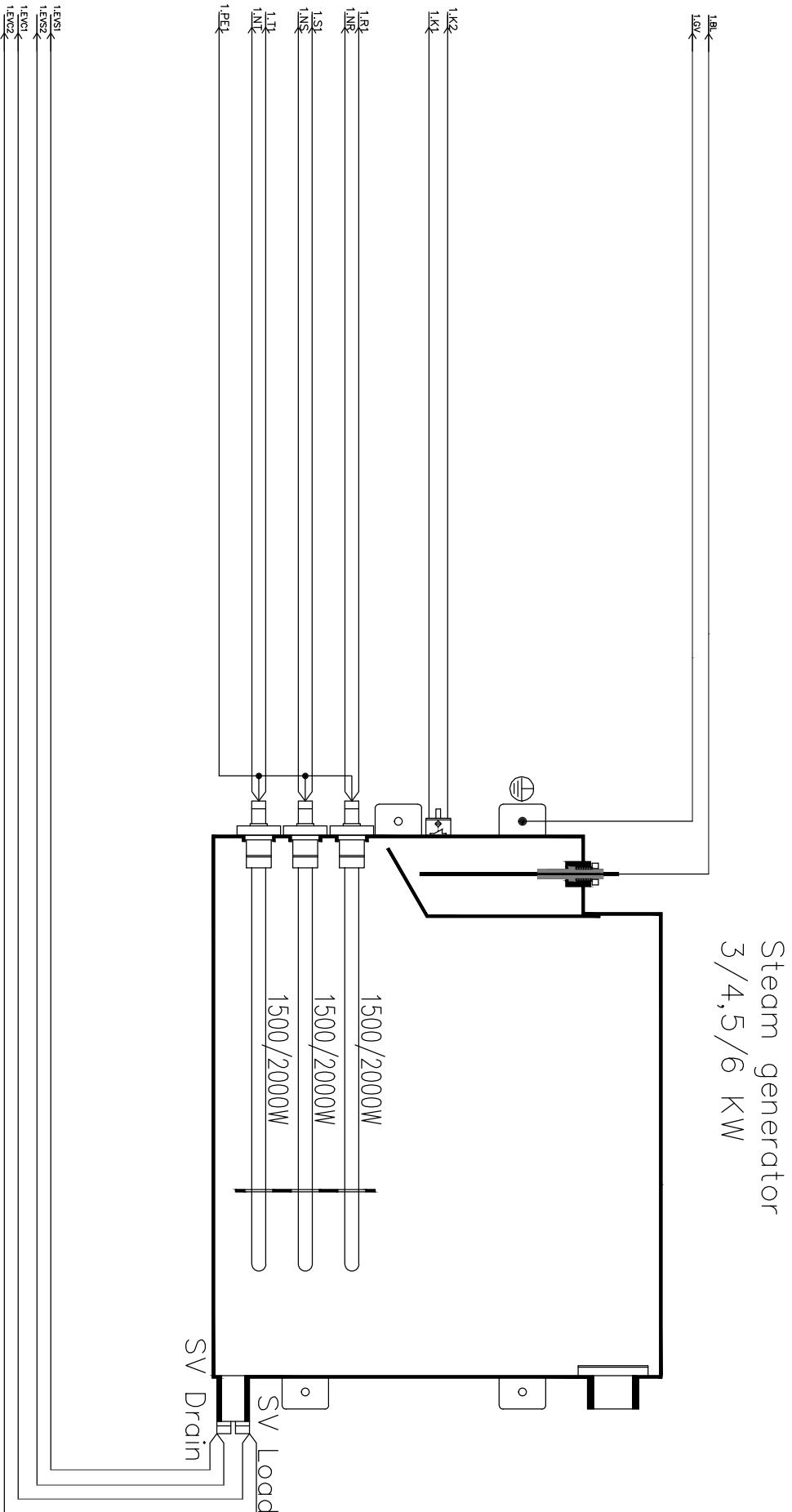

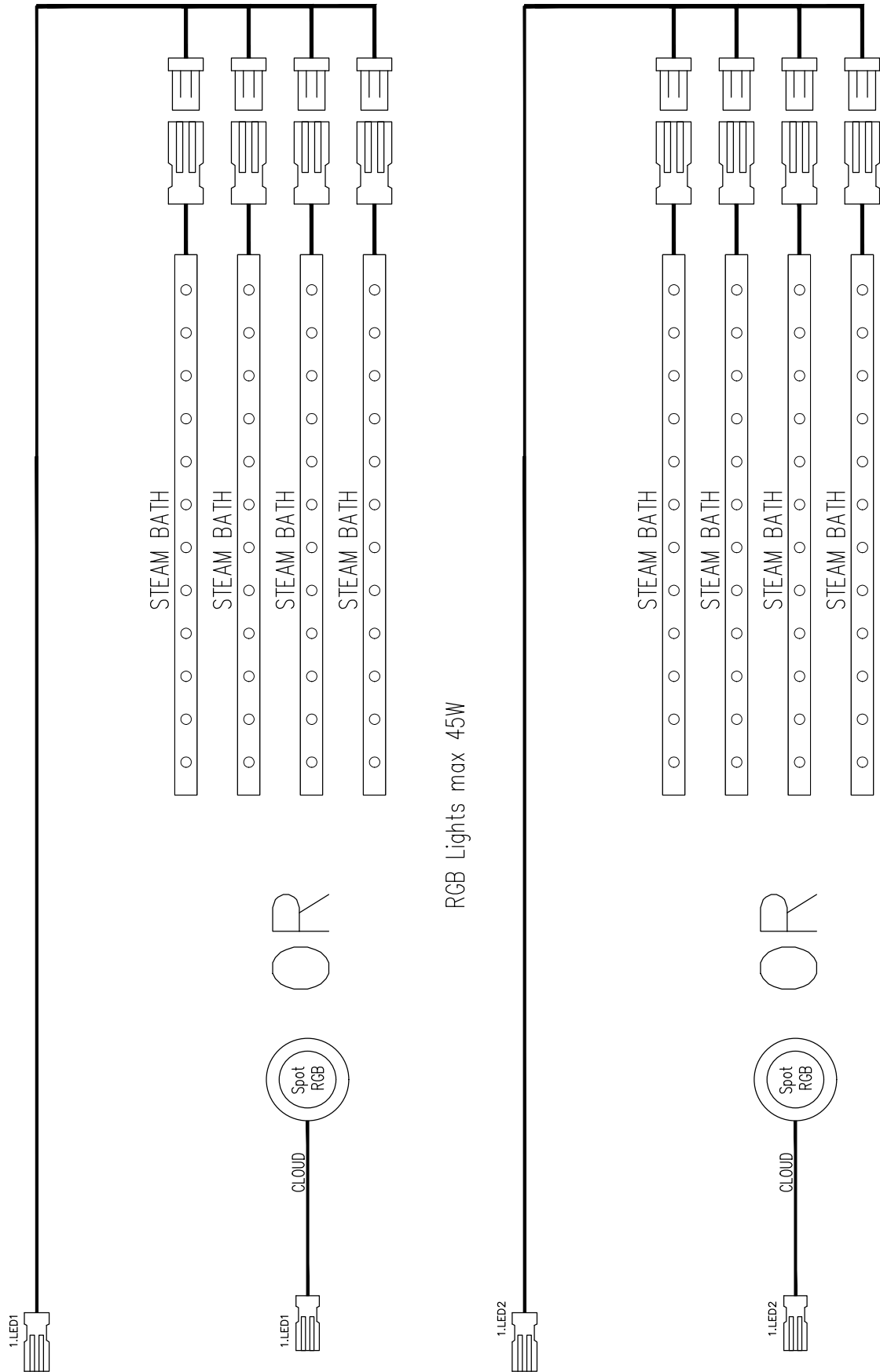

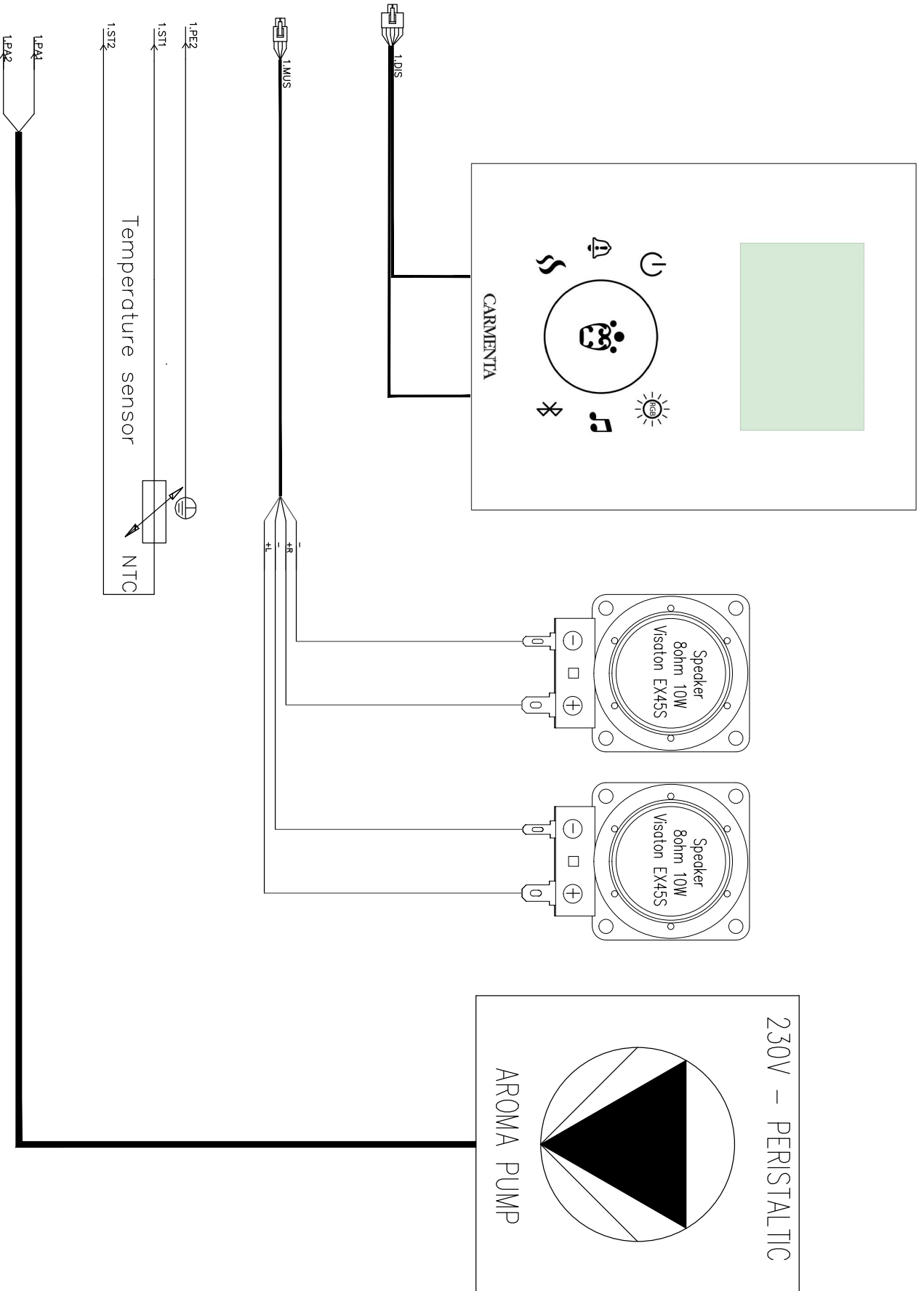

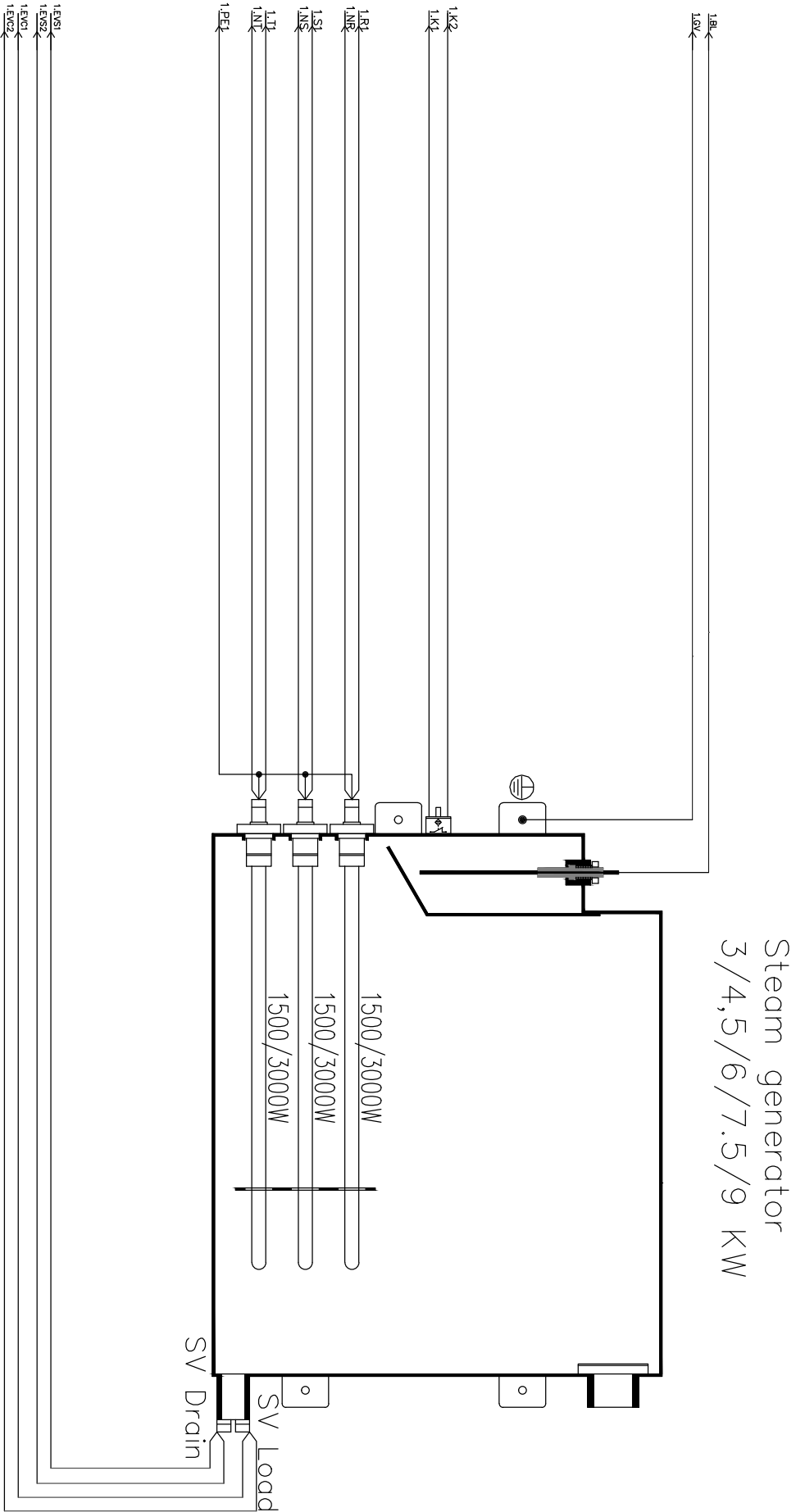

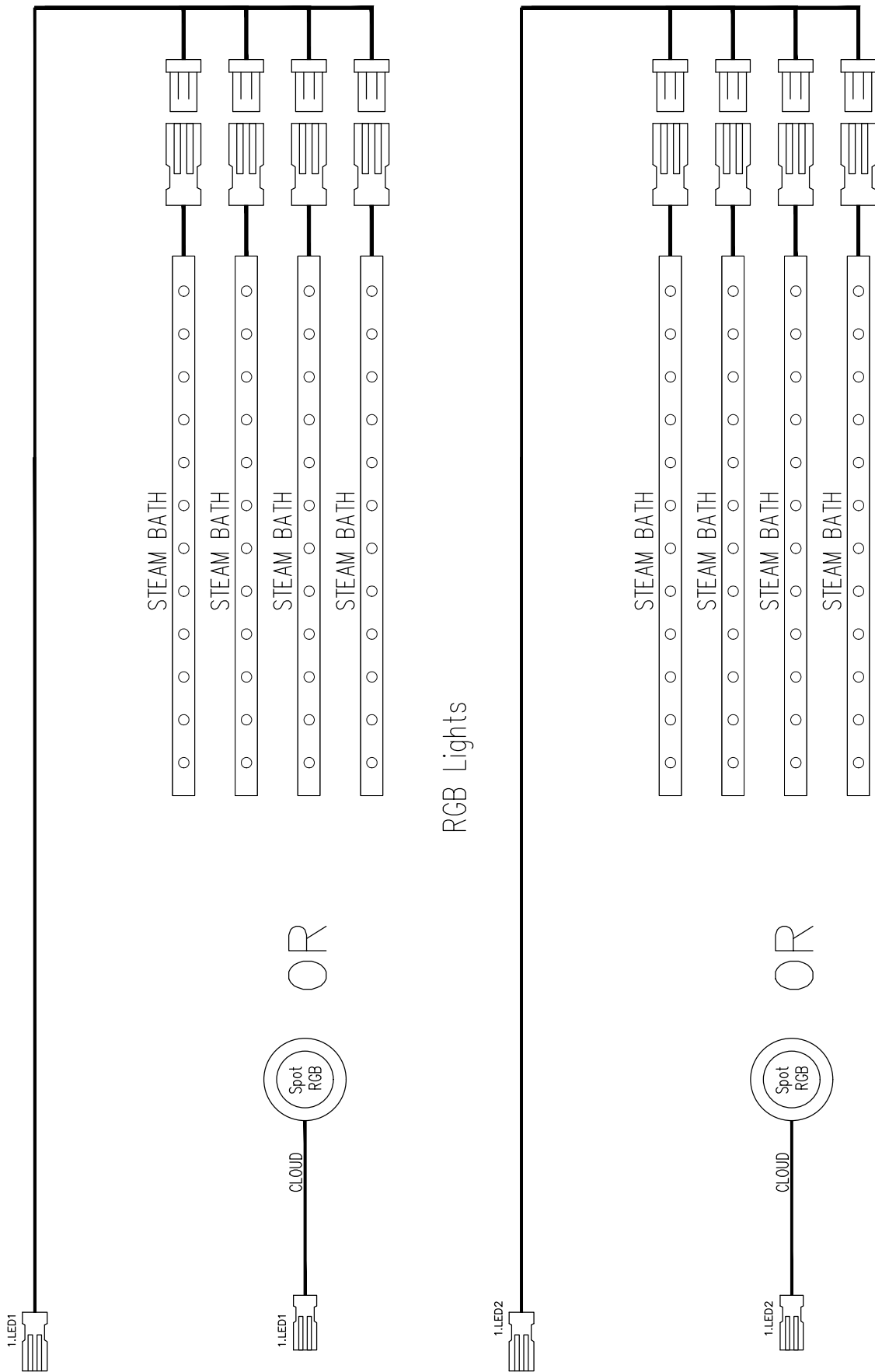

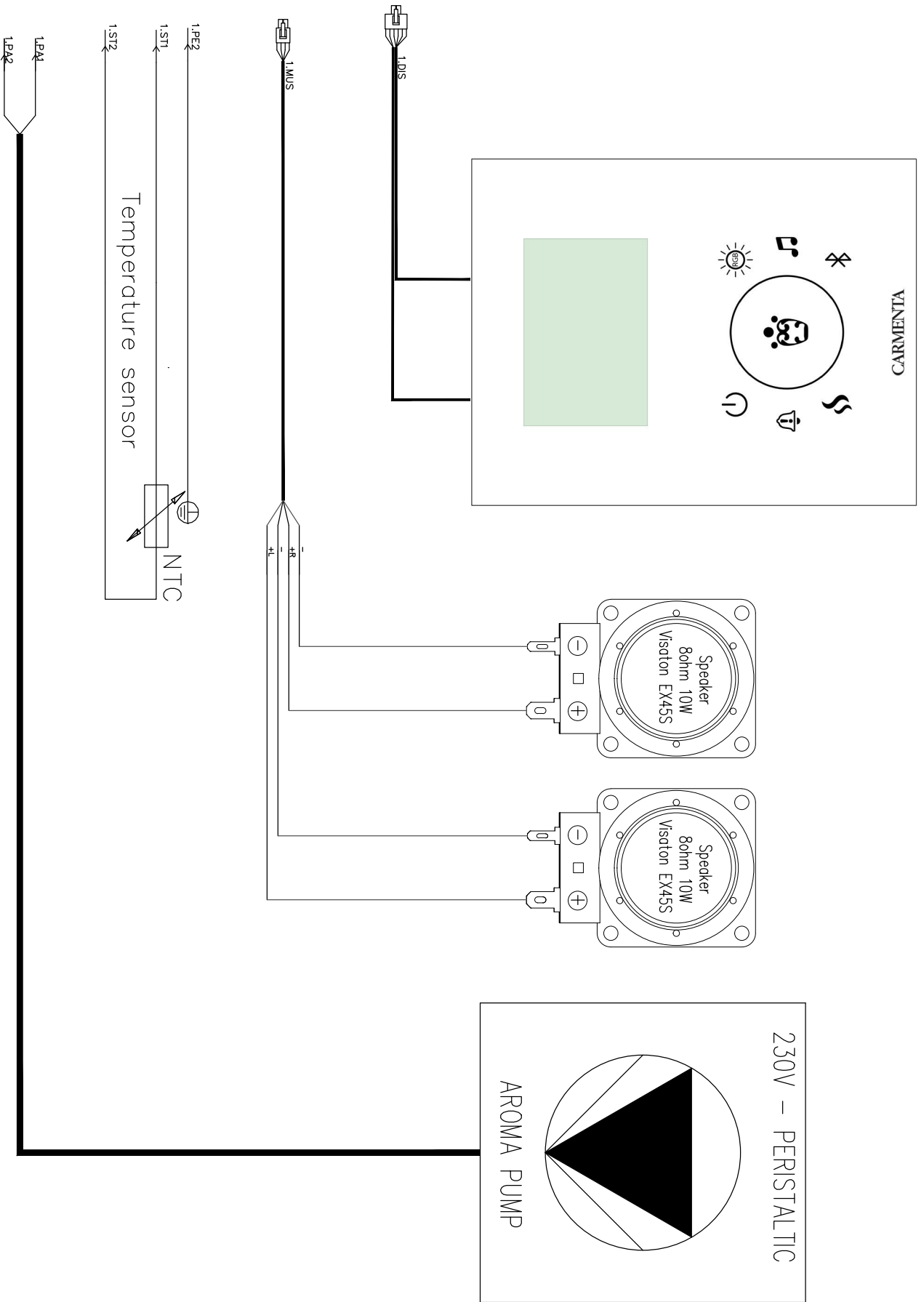

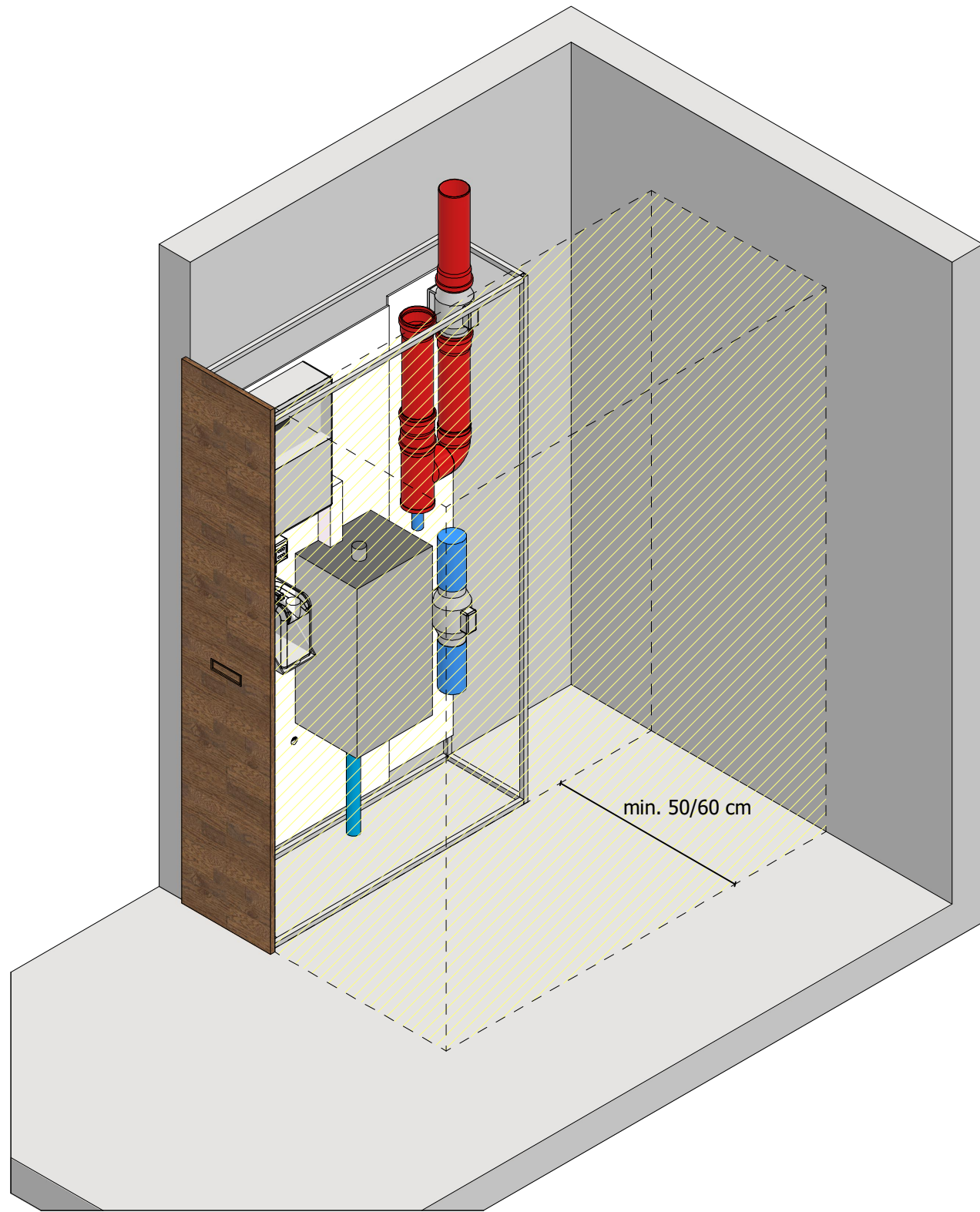

For the assembly of the sliding technical panel, at least 50/60 cm of space is required to allow the fitter to screw the frame

1. *The panel arrives already assembled, it is necessary to unhook the guides from the panel with the technique*

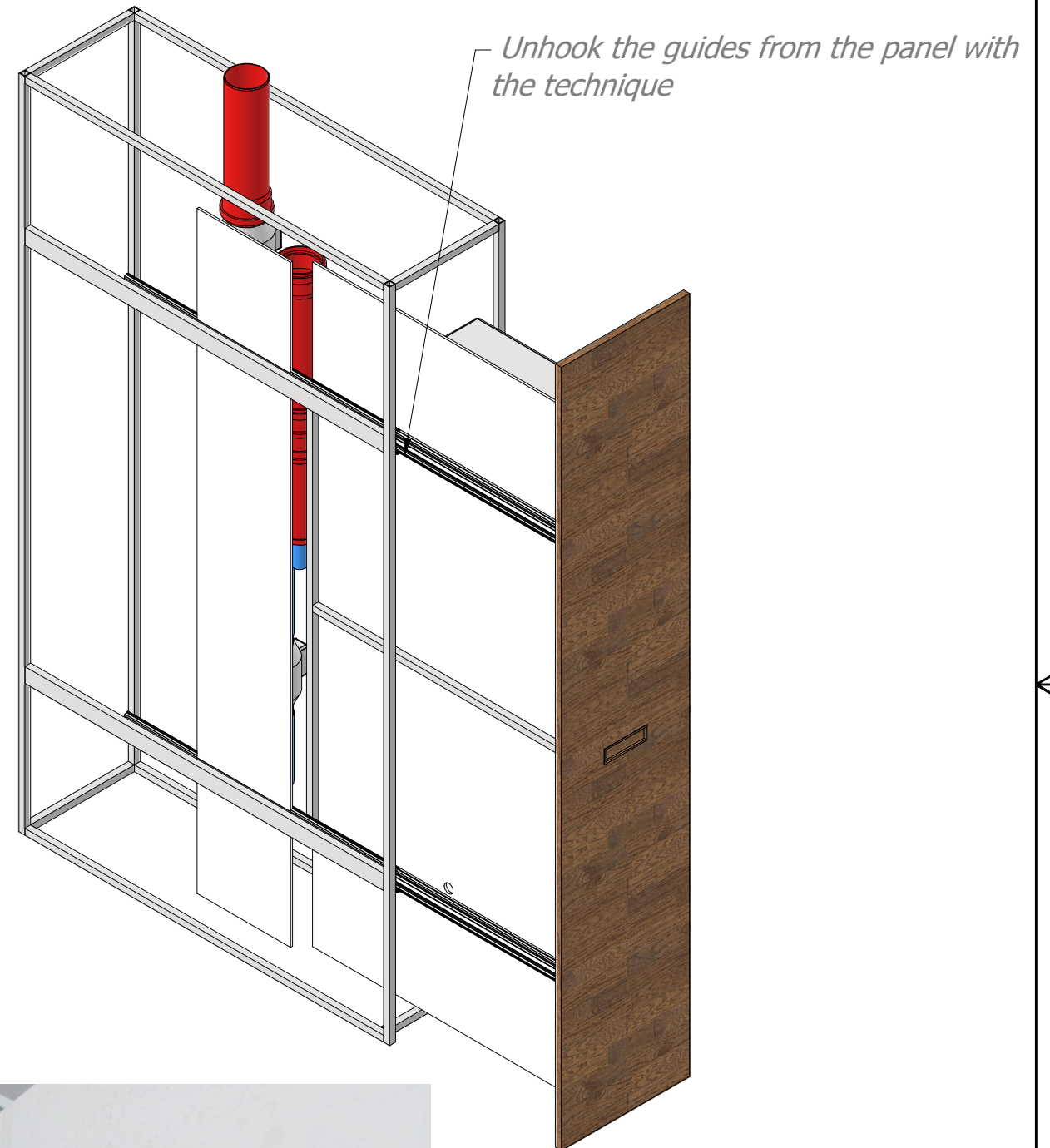

2. *Position the frame level and screw it to the wall using screws suitable for the type of wall (screws not included)*

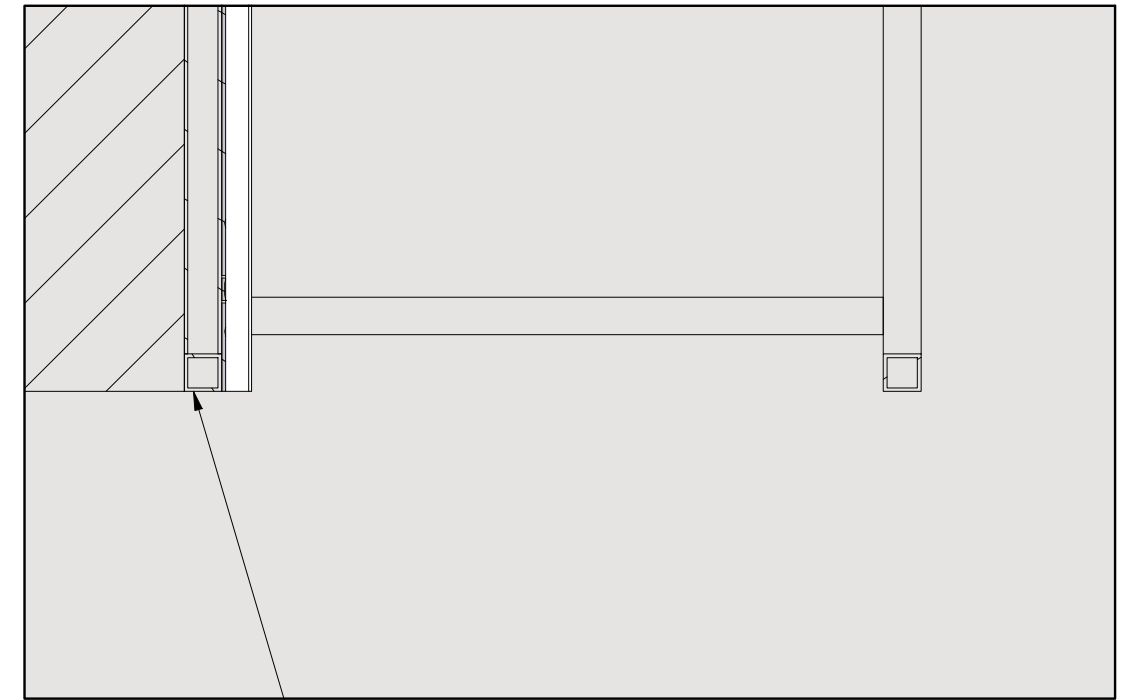
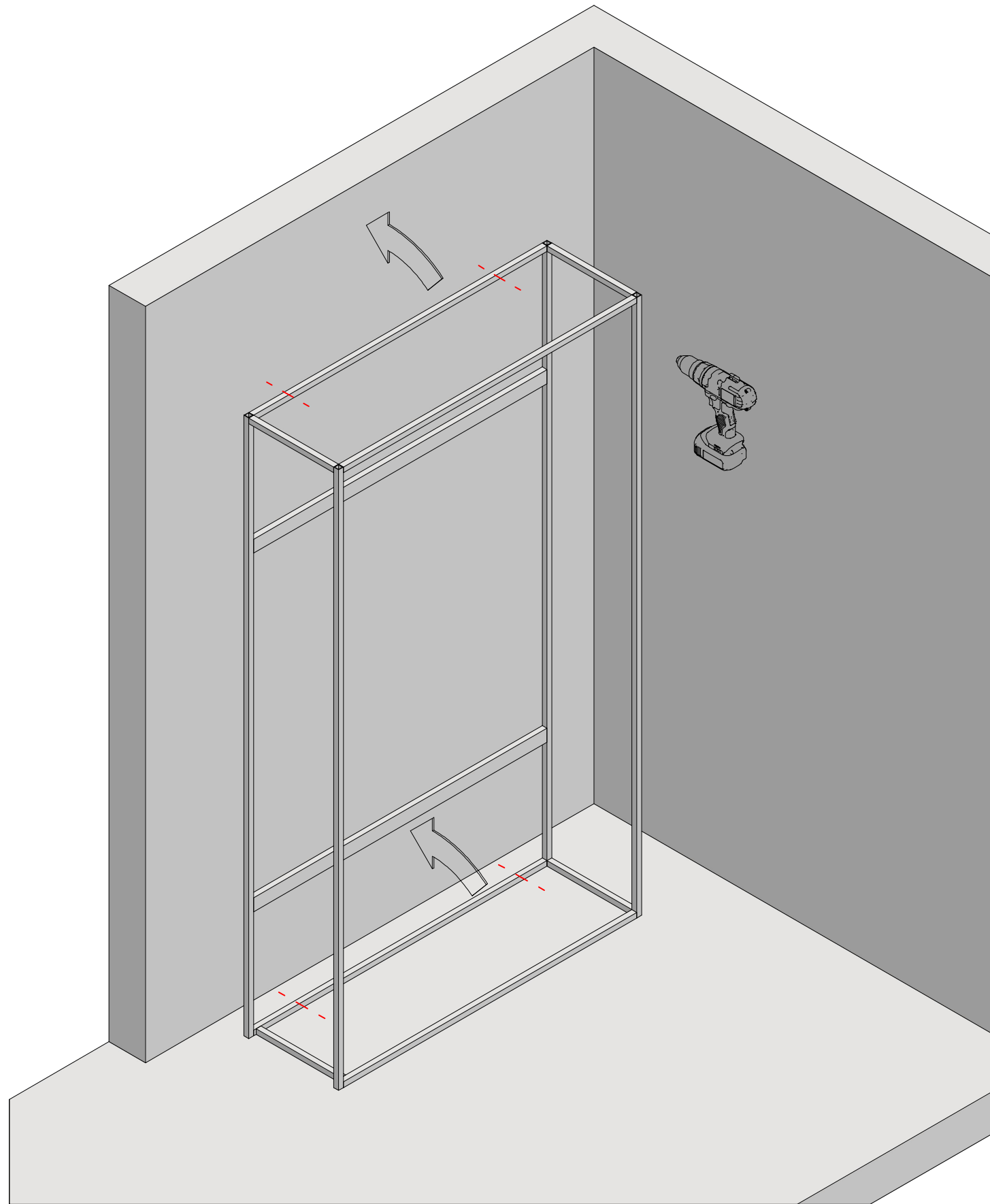

Align frame with wall

3. Hook the guides back onto the panel

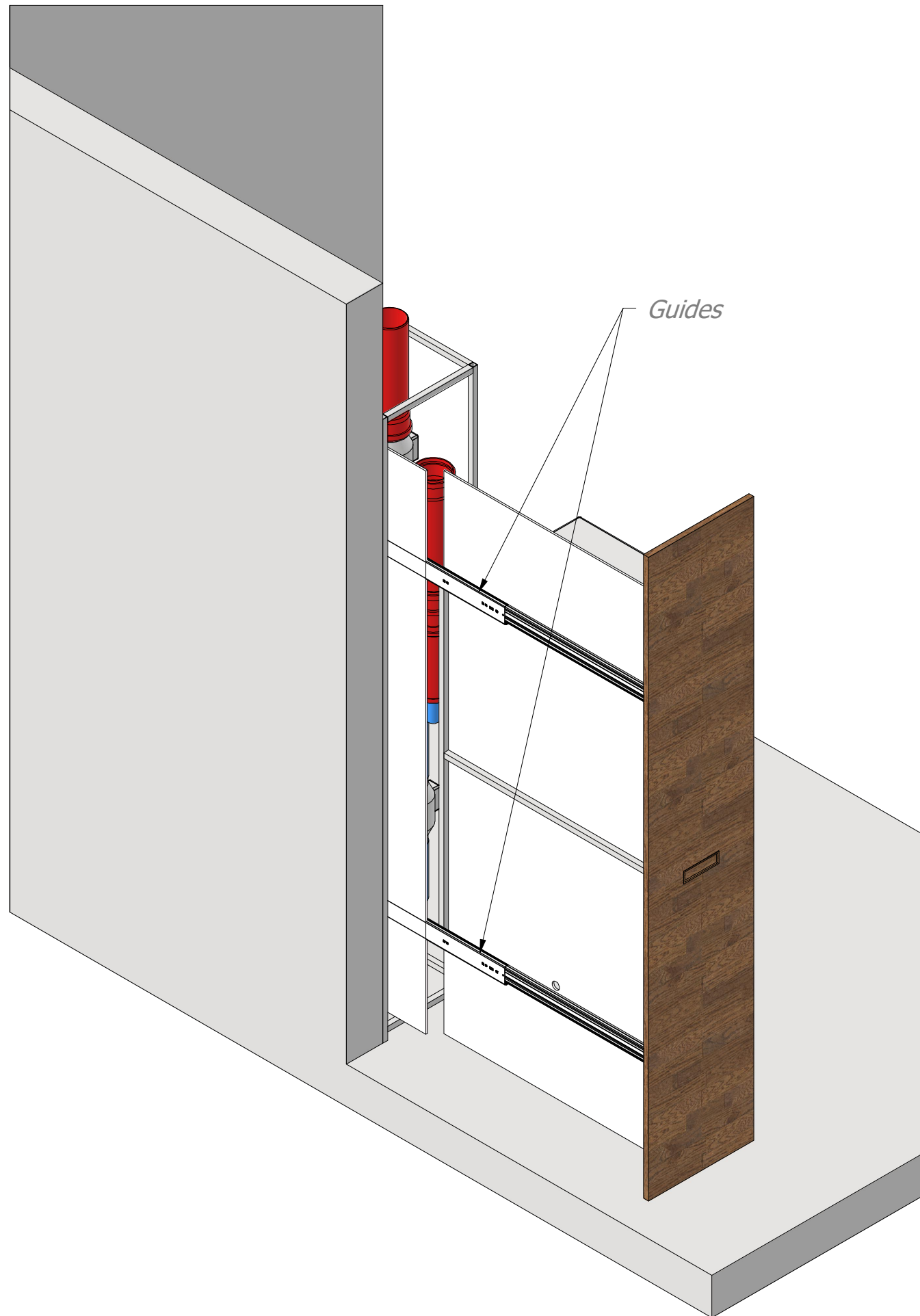

SLIDING TECHNICAL PANEL ASSEMBLY INSTRUCTIONS

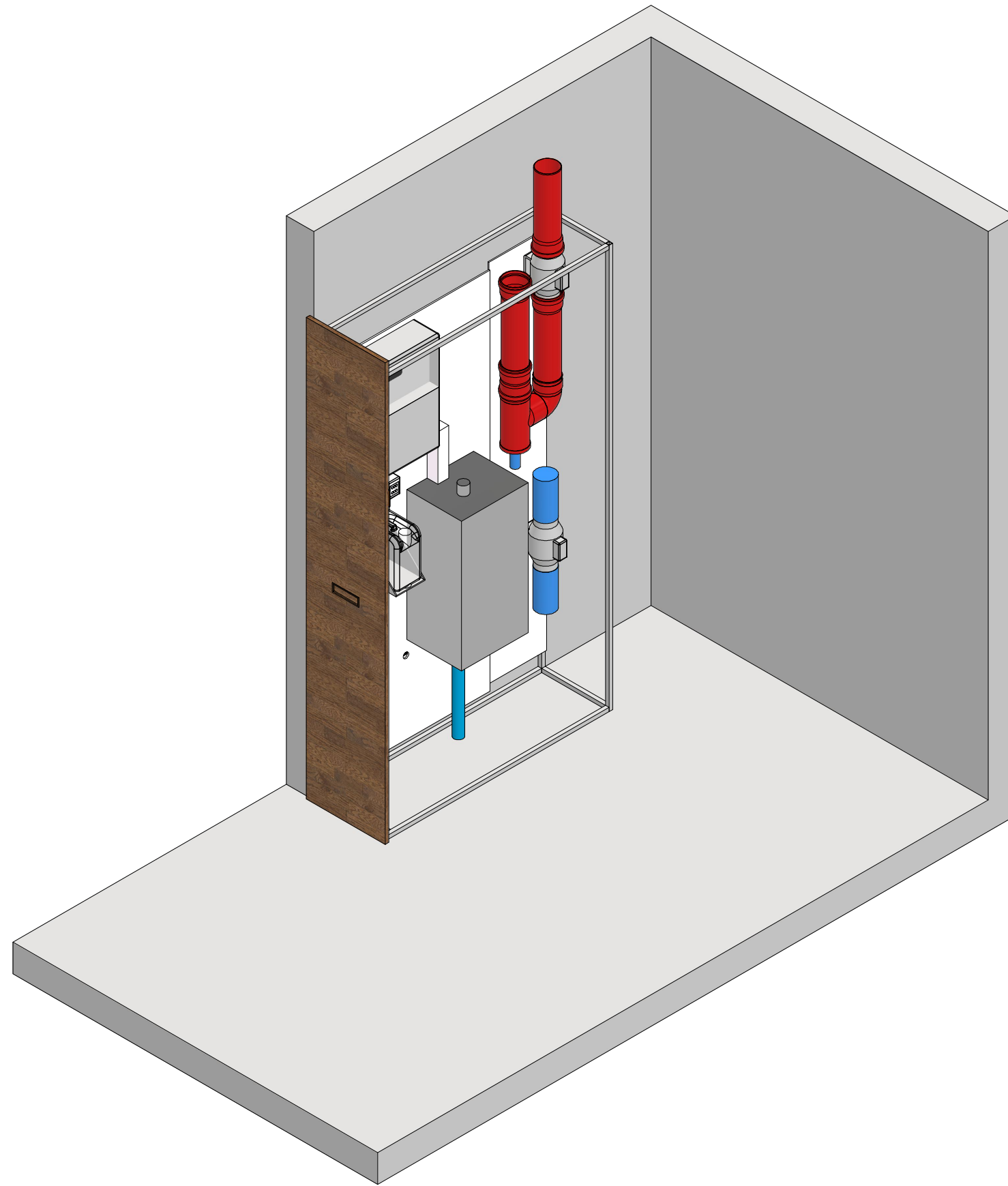

Techniques on board may vary



CARMENTA
THE WELLNESS INDUSTRY



CARMENTA SRL

Tel. +39 049 9430707

Via Trento 21/A – 35010 Carmignano di Brenta (PD) – Italy

info@carmentasrl.com – www.carmentasrl.com