

Installation and operating instructions Notice

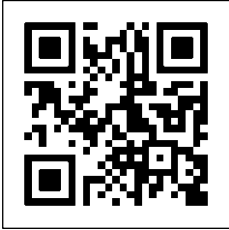

Care and cleaning

<https://www.hewi.com/de/service/downloads>

HEWI support

0044 1634 258200 (UK)
0049 5691 82-0 (international)

User information	4
Product information	8
Mounting information	10
Mounting	11
Instructions for use	29
Maintenance	32
Refill	33
Battery	34

Exclusion of liability

HEWI accepts no liability whatsoever for damage to persons or property that occurs or has occurred as a result of improper mounting or maintenance, particularly if the safety instructions and other points to note listed are not or have not been observed in full. HEWI accepts no liability whatsoever for damage occurring from incorrect cleaning.

Safety instructions

These instructions are intended for qualified skilled personnel and the user of the installed product. Following installation, the instructions must be made available to the user.

- Follow with the installation instructions and instructions for use.
- In case of questions, problems, uncertainties or if damage occurs, contact the HEWI support service.
- Ensure that the product is installed, maintained and repaired by qualified, skilled personnel only.
- Check the product for damage on acceptance. Report defects immediately.
- Install/use the product only:
 - in accordance with its intended purpose
 - in its original condition without modifications
 - in perfect condition
- Use original spare parts only.
- Use only HEWI fixing materials.
- Ensure that the wall structure in the installation area is even and adequately load-bearing.
- Only use in closed rooms.

Disposal

Disposal of the product and packaging is subject to the relevant national regulations.

Product information

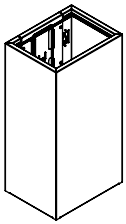

900.05.001...

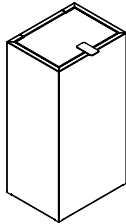

900.05.002...

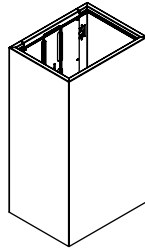

900.05.003...

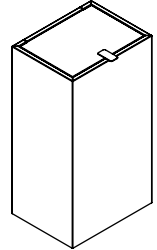

900.05.004...

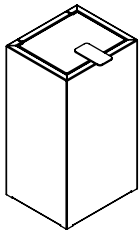

900.05.005...

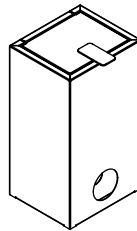

900.05.006...

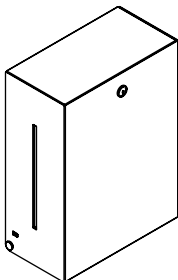

900.06.009...

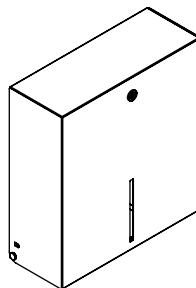

900.21.001...

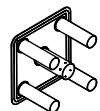

900.21.E01

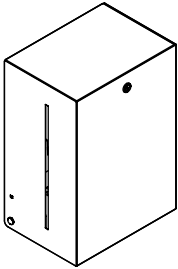

900.06.010...

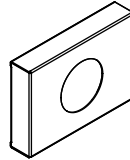

900.06.011...

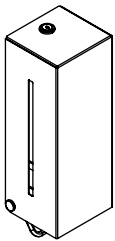

900.06.004...

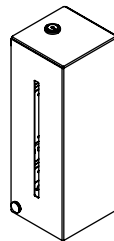

900.06.005...
900.06.007...
900.06.008...



Tools required

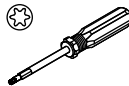

T 20
T 25

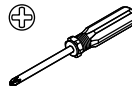

PZ 2

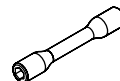

SW 7



SW 7
SW 8

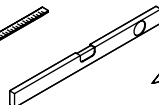
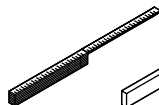

Ø 6
Ø 8

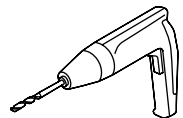

Mounting information

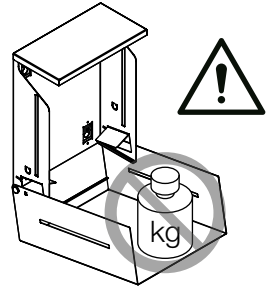
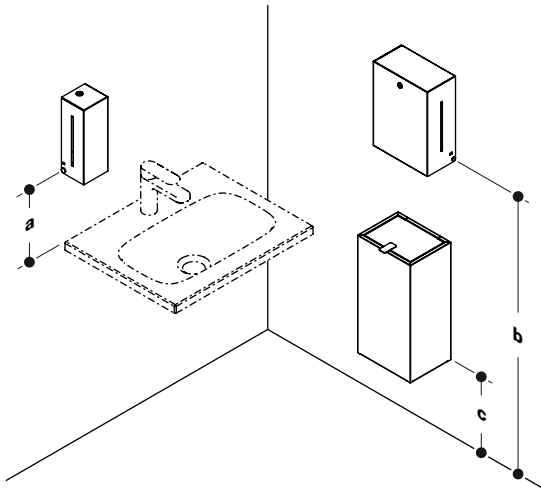

a \geq 200 mm

b* = 1200-1400 mm

c* \geq 200 mm

*Recommended heights

adjust heights as required in schools, daycare facilities etc.

Mounting

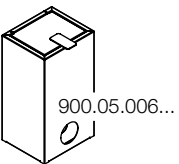
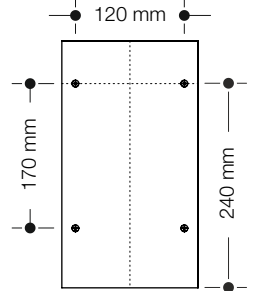
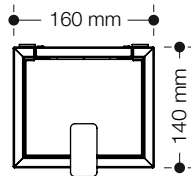
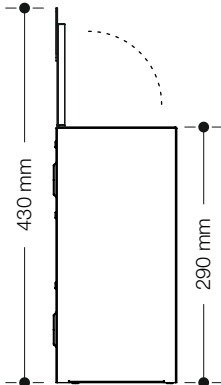
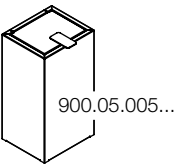
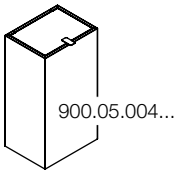
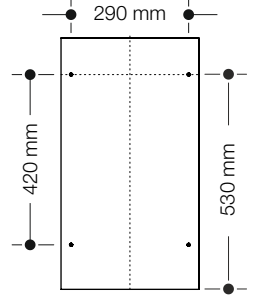
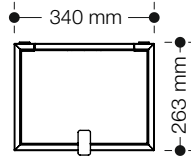
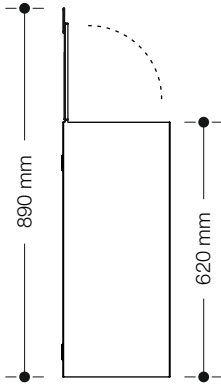
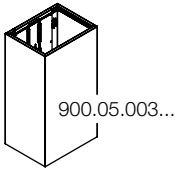
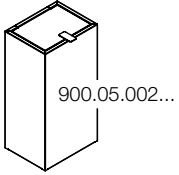
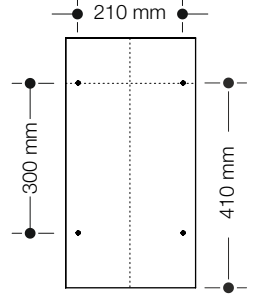
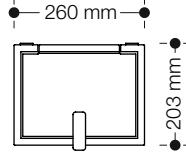
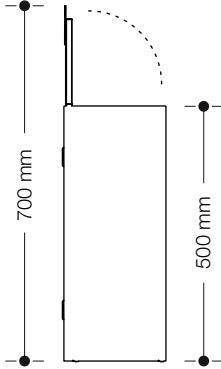
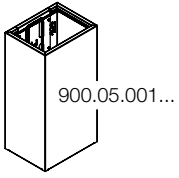

Mounting

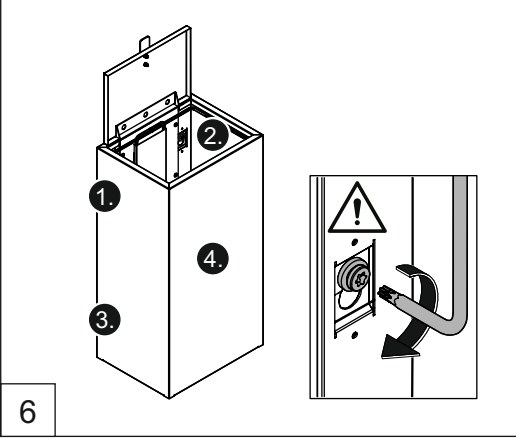
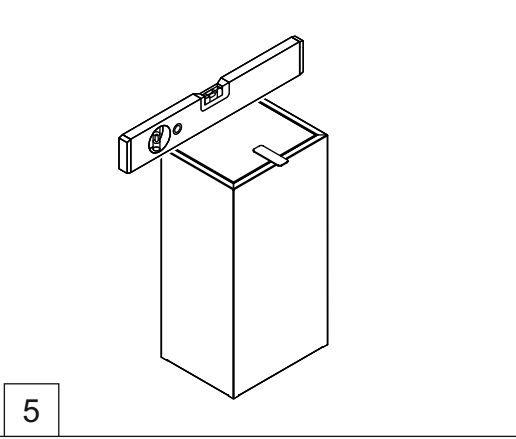
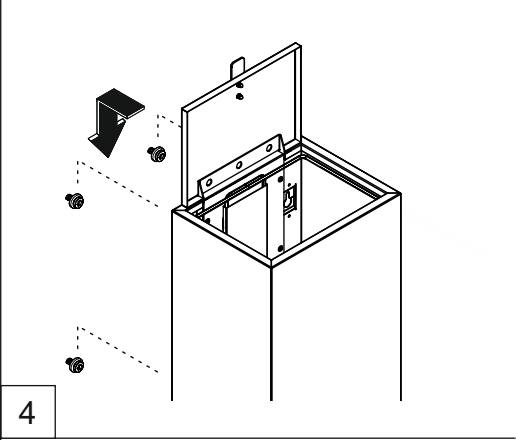
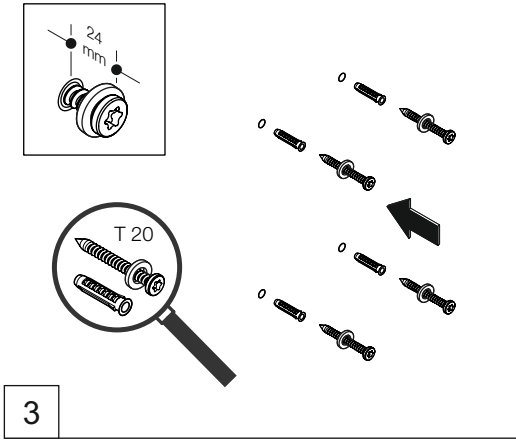
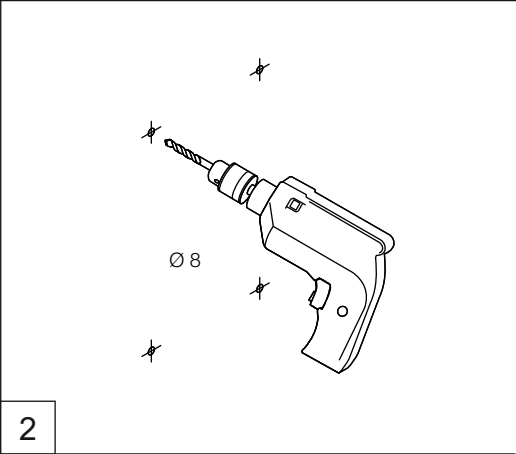
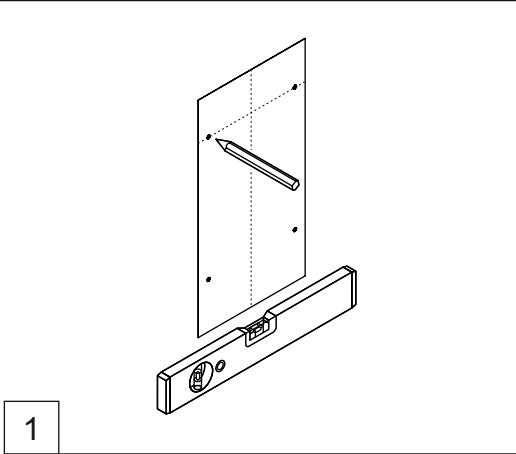

Mounting

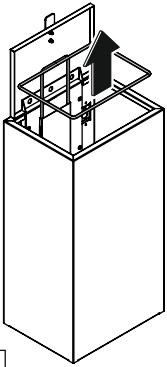

900.05.001...	25-30 l
900.05.002...	
900.05.003...	6 l
900.05.004...	
900.05.005...	6 l
900.05.006...	

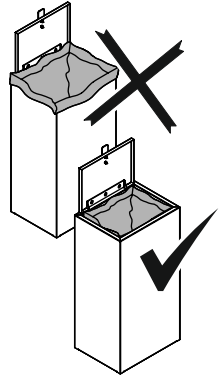
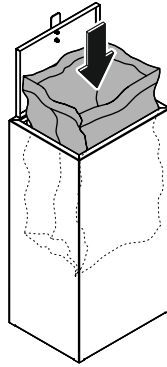
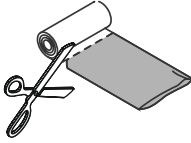

7

8

Optional

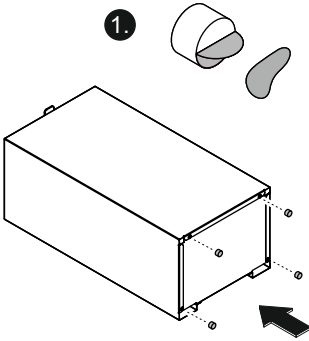

900.05.001
900.05.002
900.05.003
900.05.004

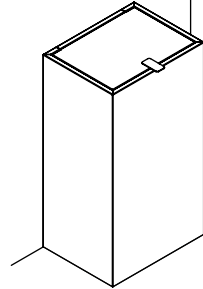

1

2

Optional

900.05.006

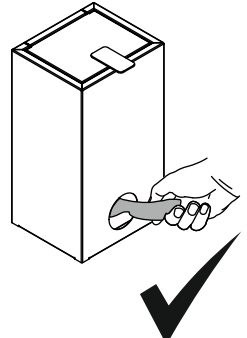
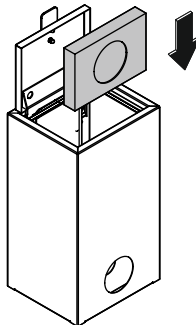
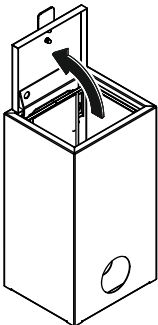

1

2

3

Mounting

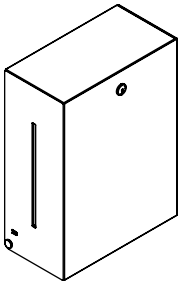

900.06.009...

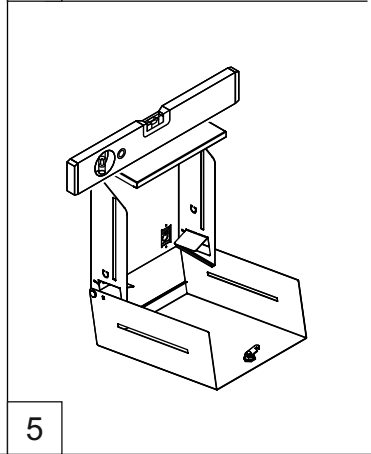
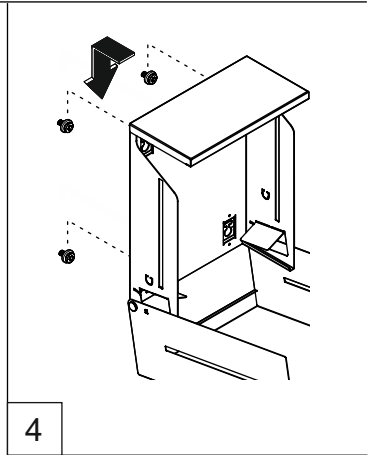
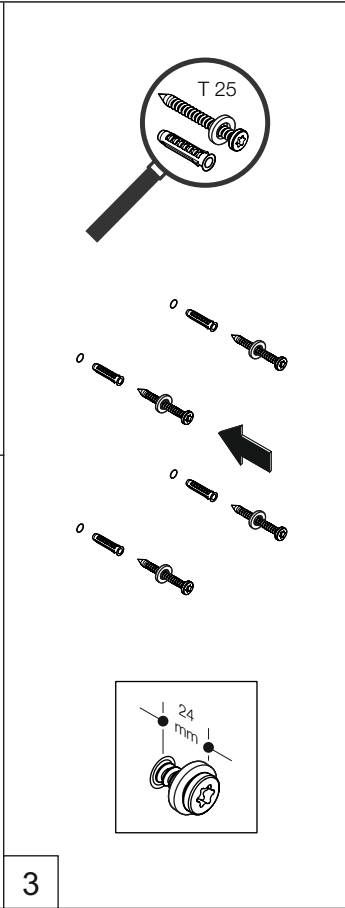
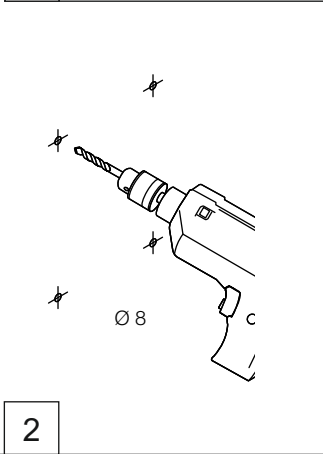
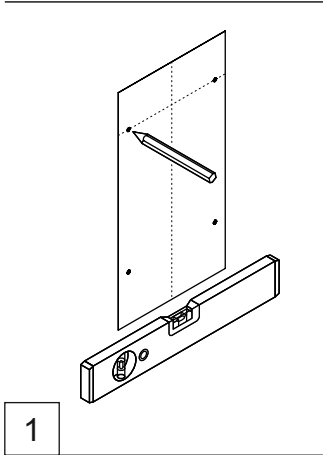
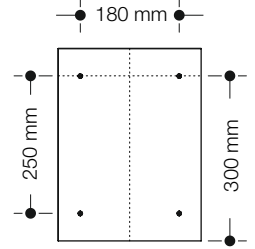
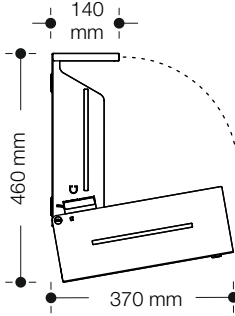
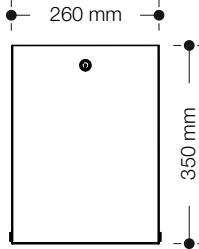

Mounting

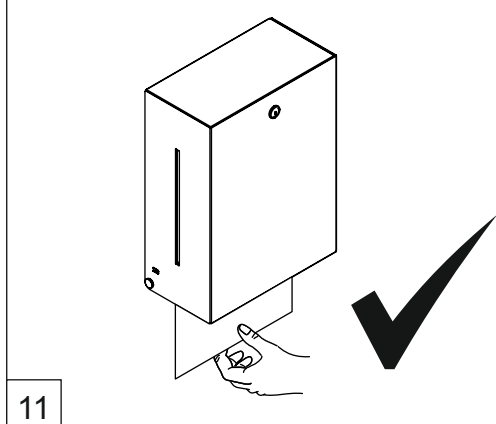
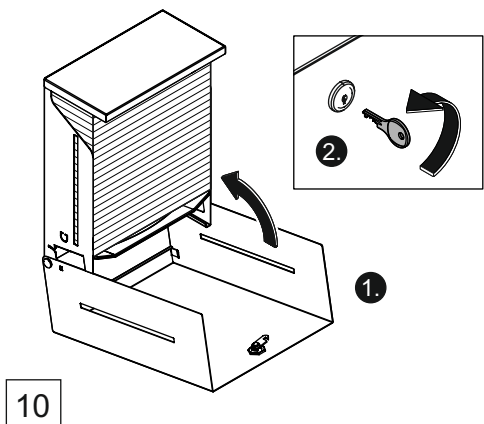
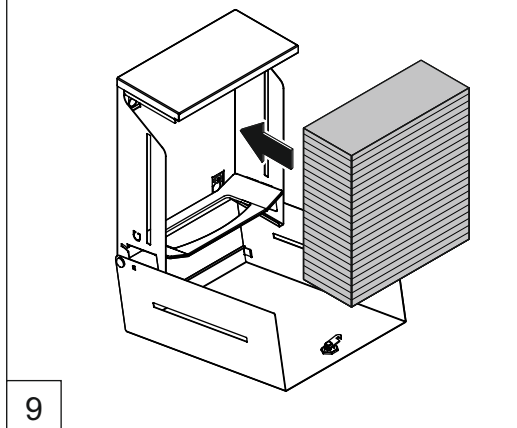
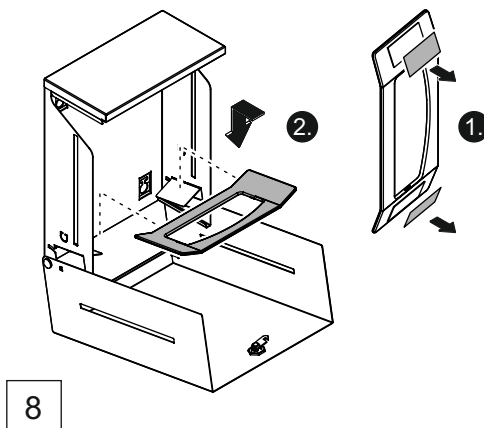
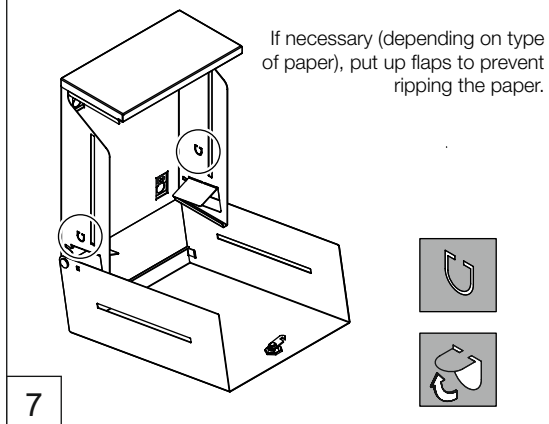
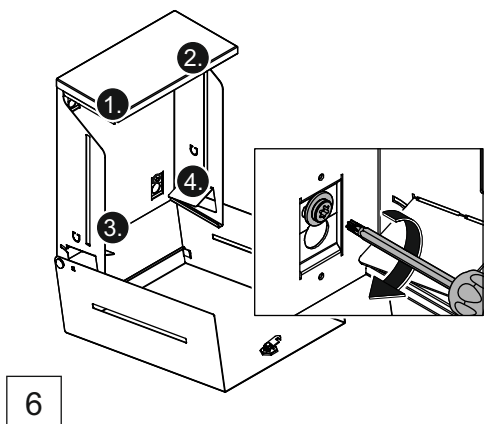

Mounting

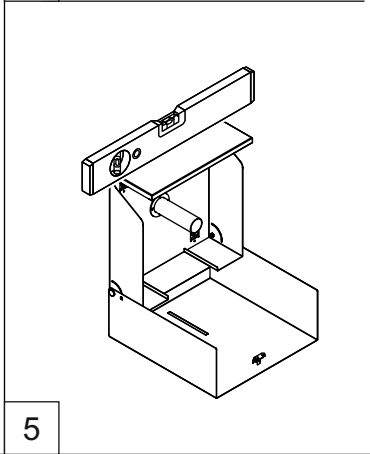
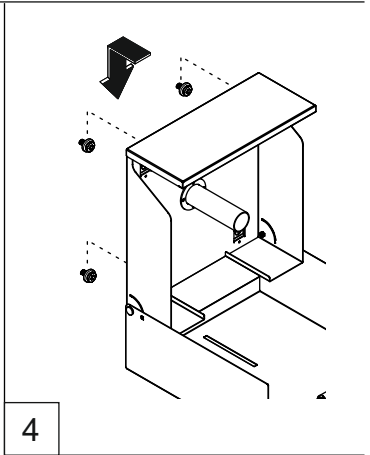
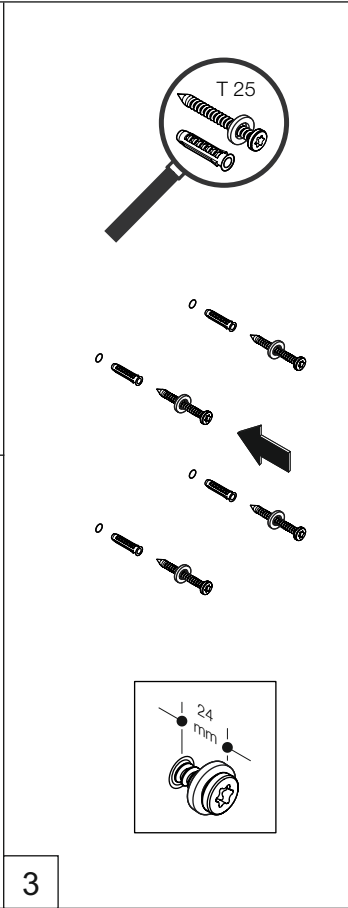
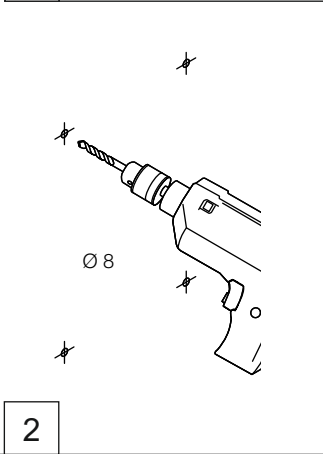
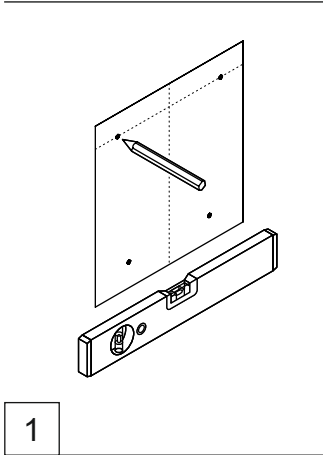
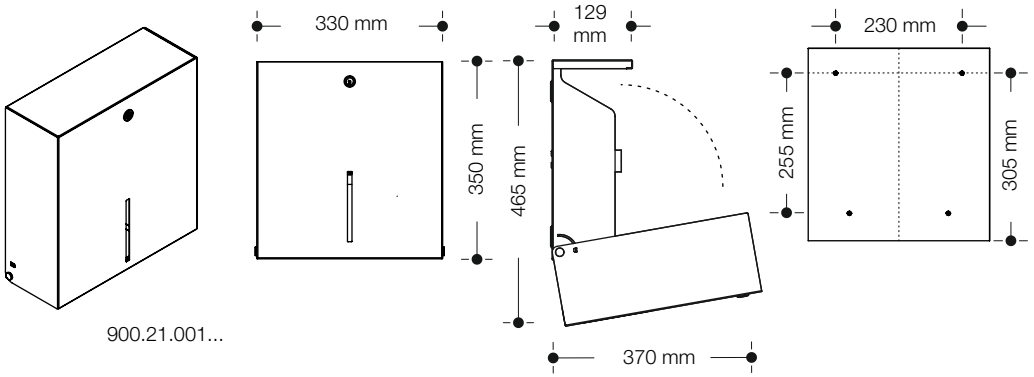

Mounting

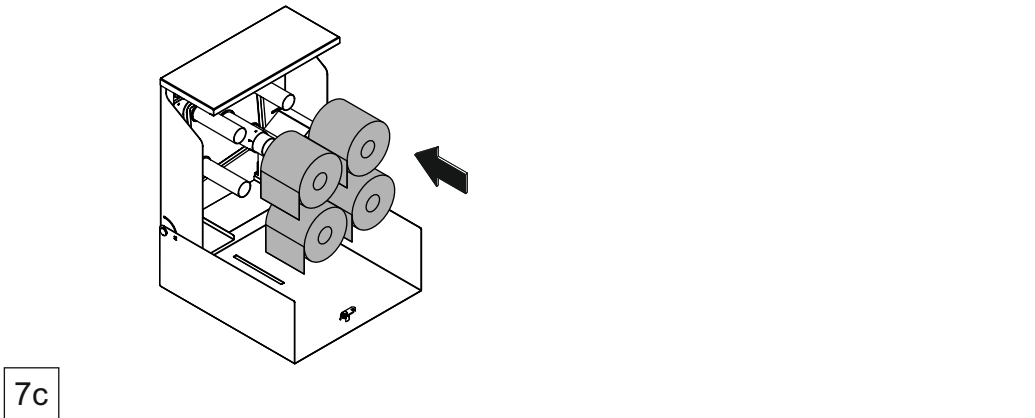
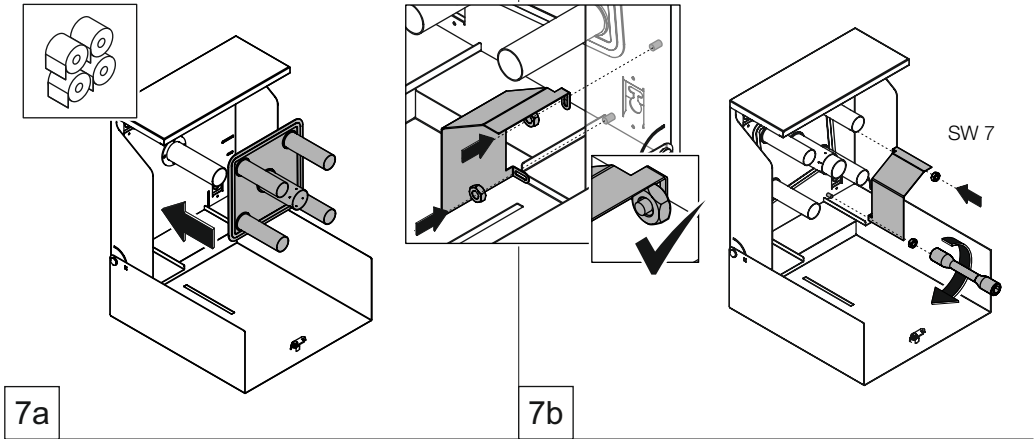
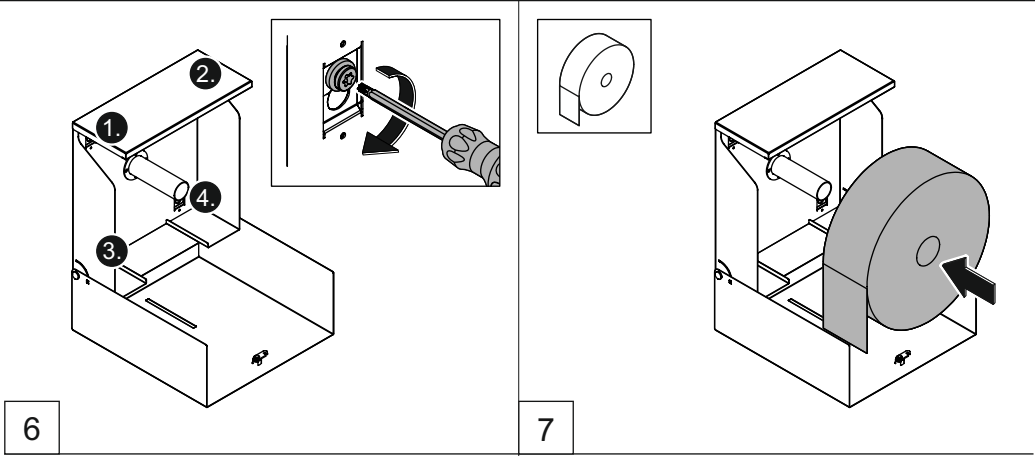

Mounting

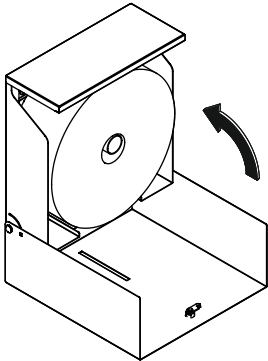

8

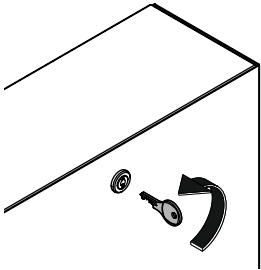

9

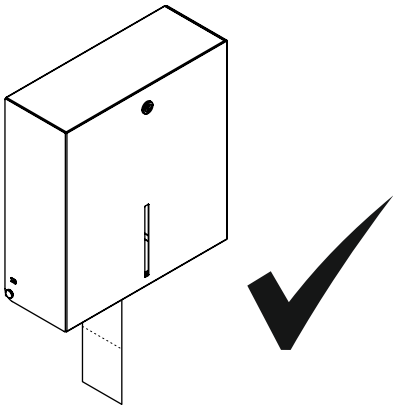

10

Mounting

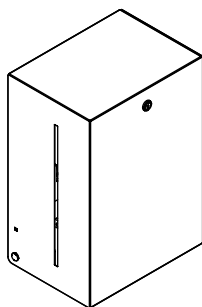

900.06.010...

284 mm

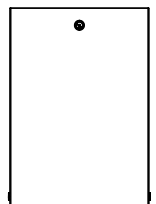

405 mm

210 mm

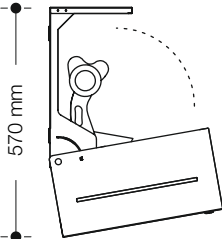

570 mm

430 mm

200 mm

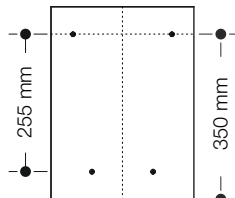

255 mm

350 mm

132 mm

89 mm

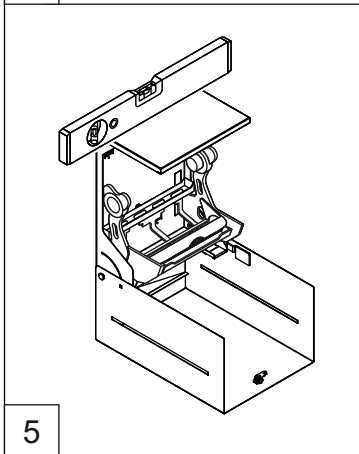
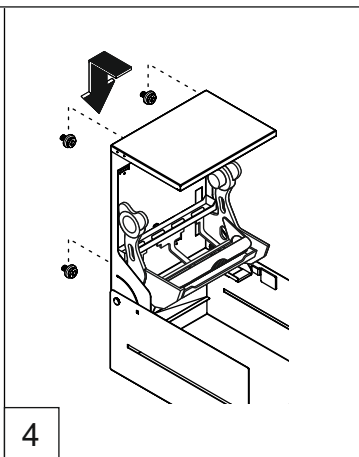
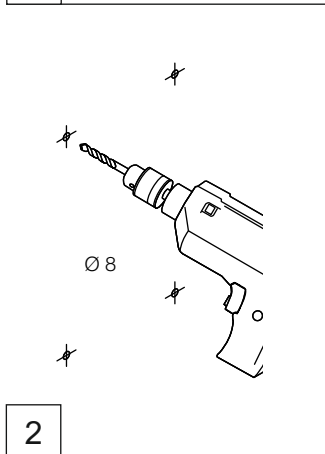
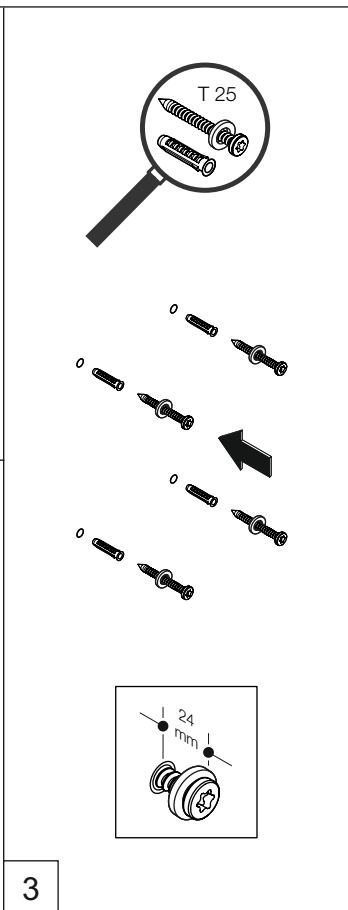
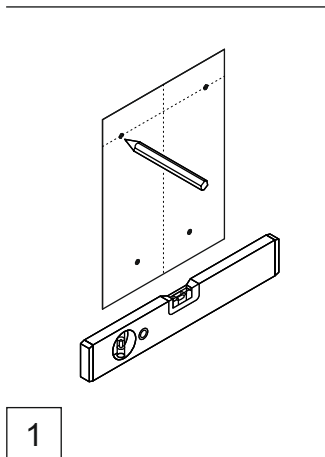

Mounting

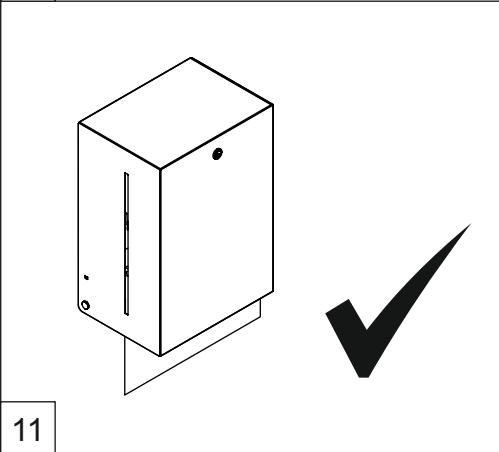
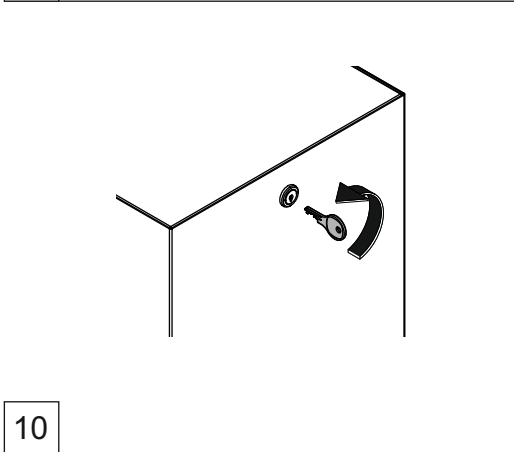
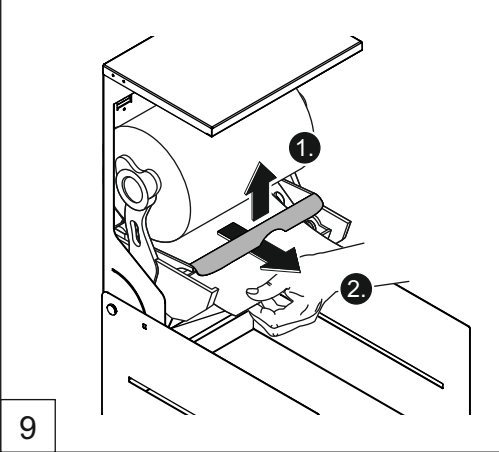
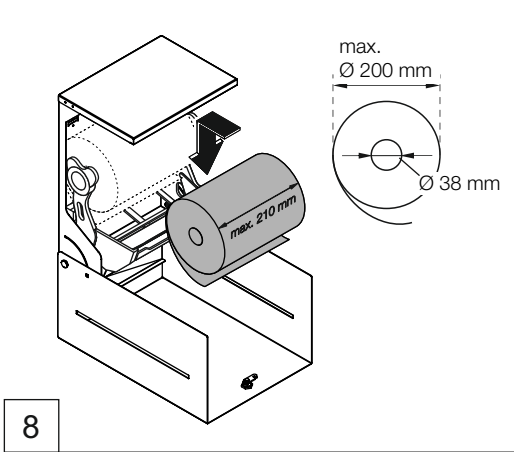
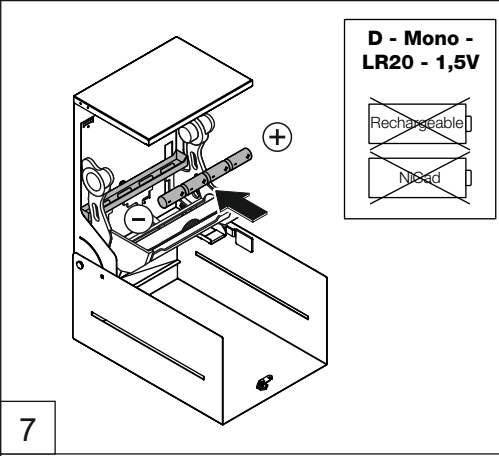
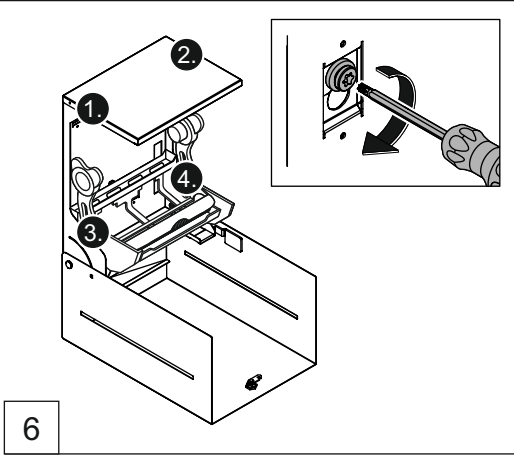

Mounting

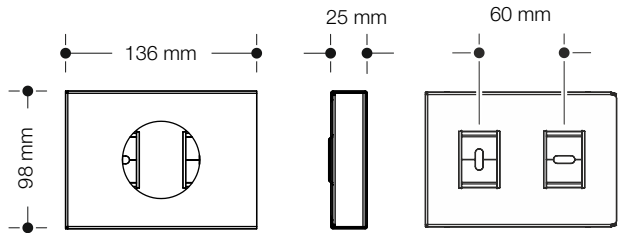
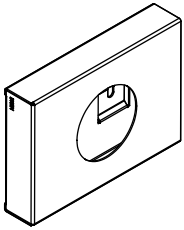

900.06.011...

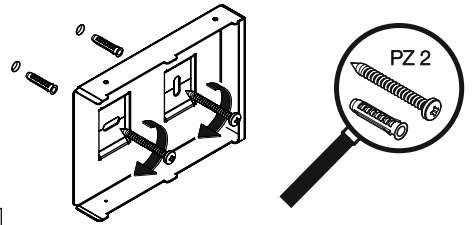
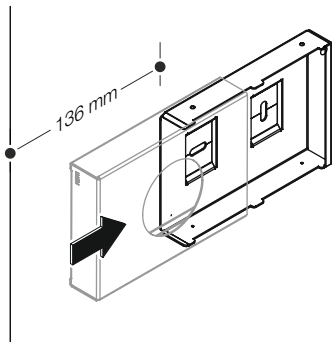

2

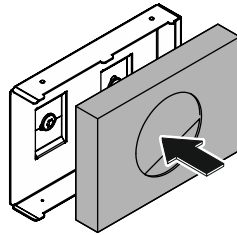

3

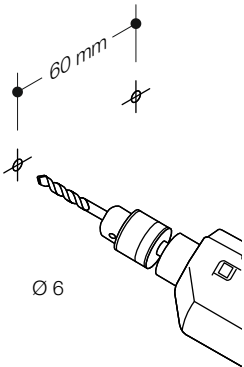

1

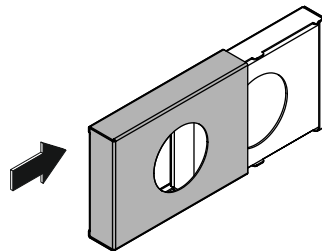

4

Mounting

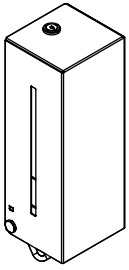

900.06.004...

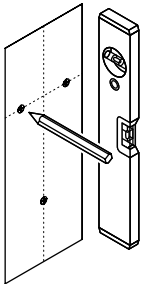
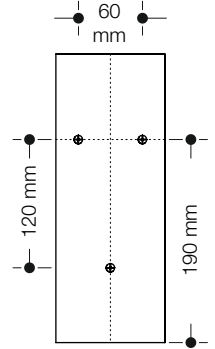
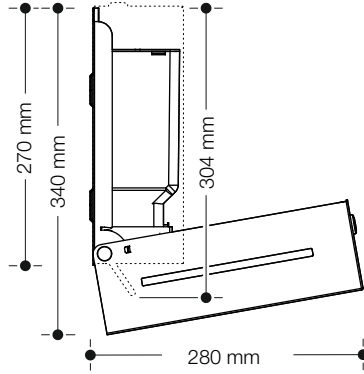
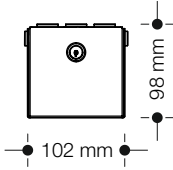

1

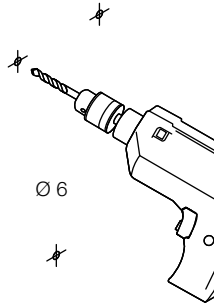

2

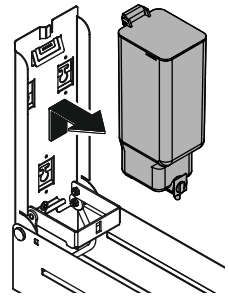

3

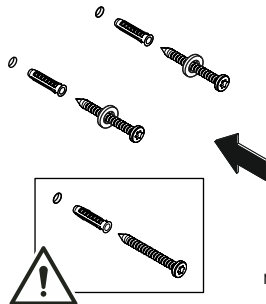
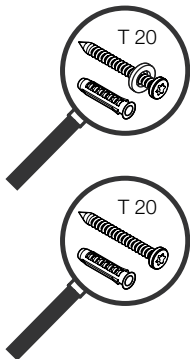

no washer

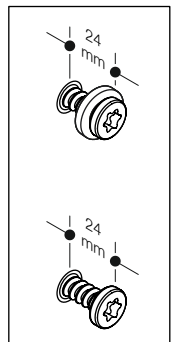

4

Mounting

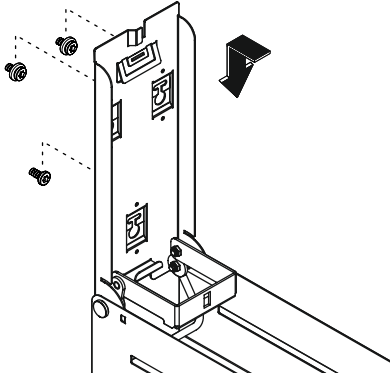

5

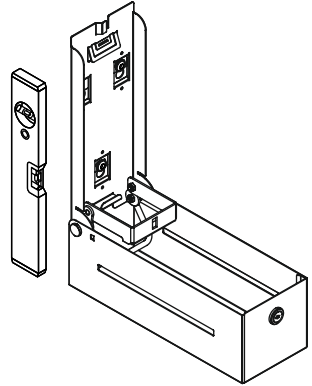

6

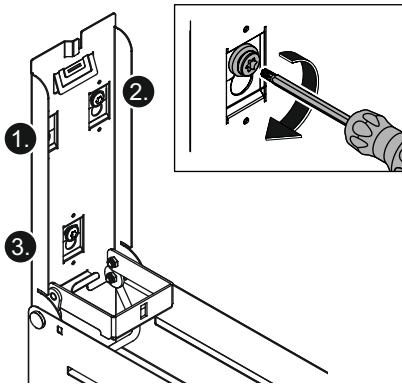

7

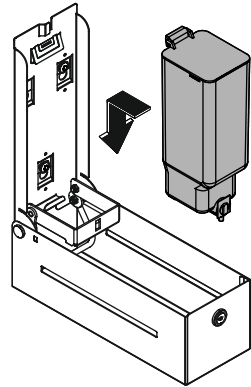

8

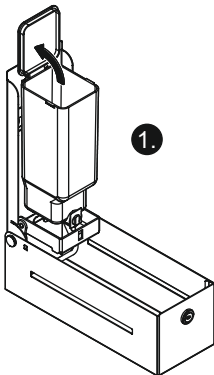

1.

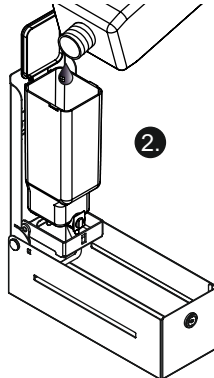

2.

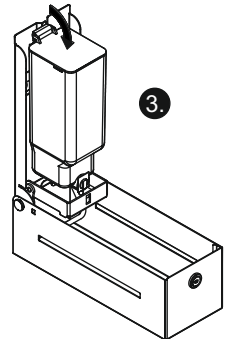

3.

9

Mounting

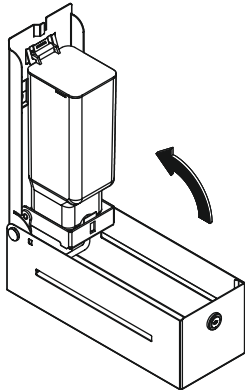

10

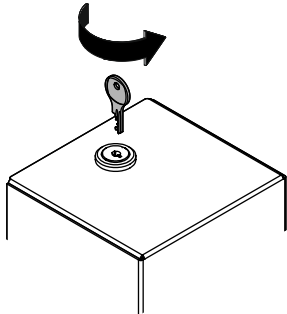

11

Mounting

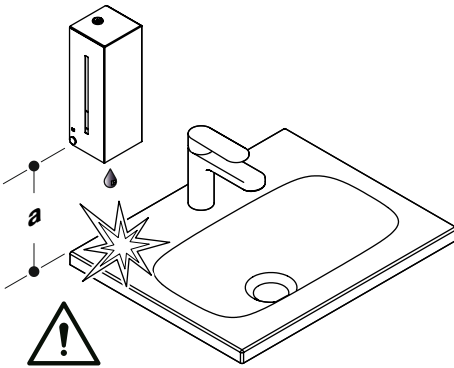
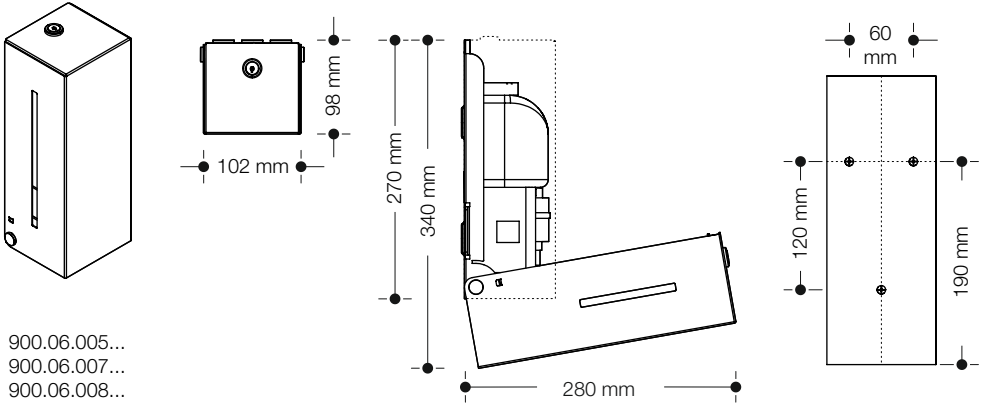

$a \geq 200 \text{ mm}$ ✓

$a < 200 \text{ mm}$

Unintentional activation by
light reflection (e. g. lamp)

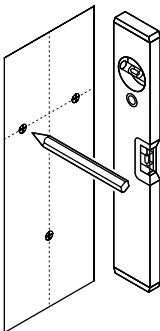

1

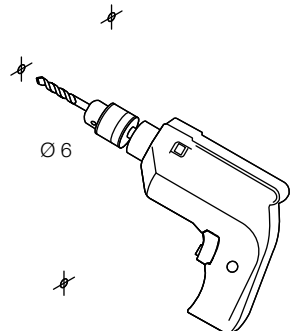

2

Mounting

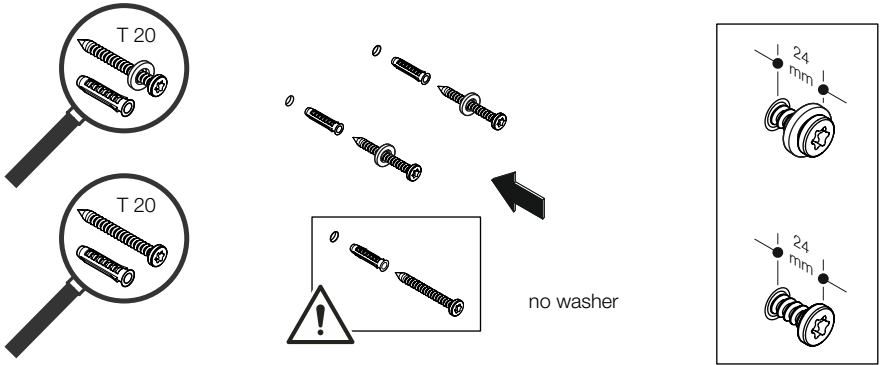

3

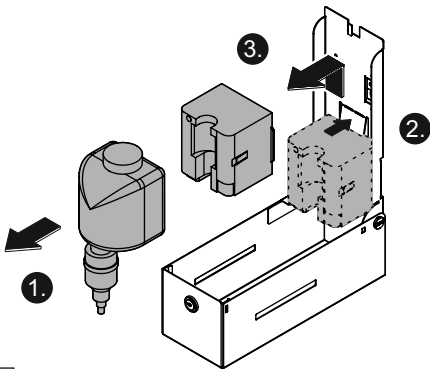

4

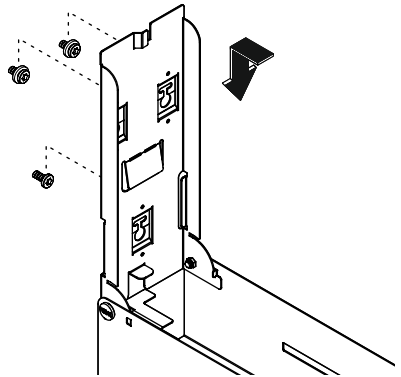

5

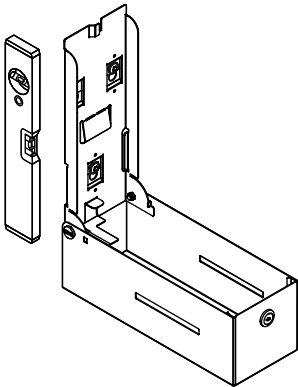

6

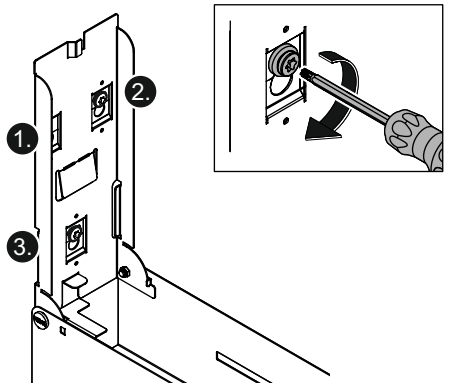

7

Mounting

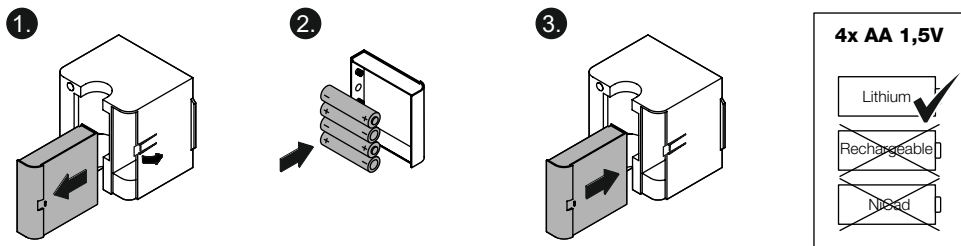

8

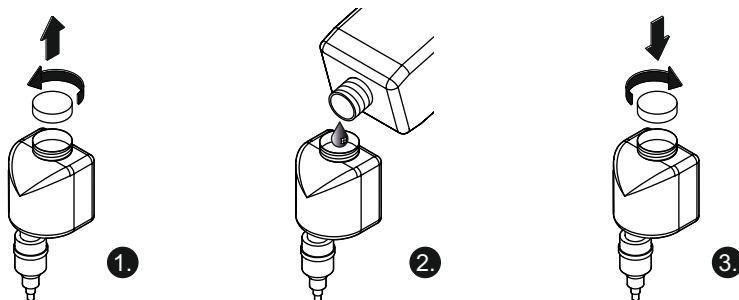

9

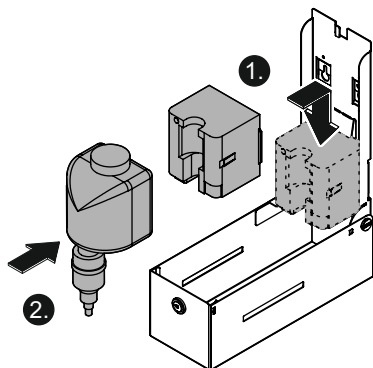

10

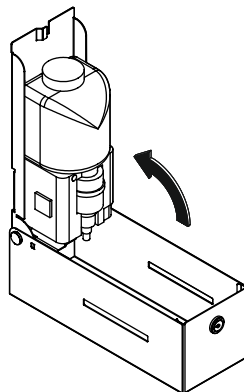

11

Mounting

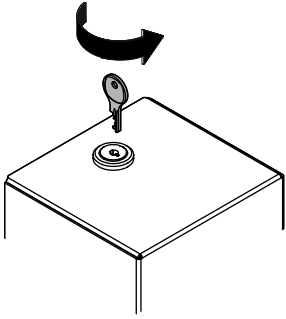

12

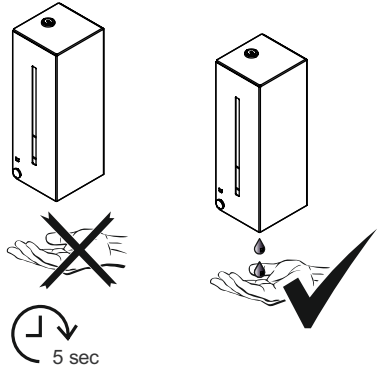

13

Instructions for use

900.06.004
900.06.005
900.06.007
900.06.008

Only suitable for		Not suitable for
900.06.007... : - foaming soap - viscosity: 1-5 cps/mPa-s	900.06.004... : - undiluted liquid soap - viscosity: 3000-4000 cps/mPa-s	liquid soaps containing scouring agents
900.06.008... : - ethanol solution	900.06.005... : - undiluted liquid soap - viscosity: 1-3000 cps/mPa-s	liquid soaps that tend to thicken due to their ingredients (e.g. natural oils, alcohol, etc.)
		other cleaning products
<ul style="list-style-type: none"> • Mixing different sorts of soaps/disinfectants might impair the function. • Do not insert any objects into soap discharge opening. • Disregarding this recommendation could lead to individual parts of the product being damaged. 		

- 900.21.001
- 900.06.001
- 900.06.010
- 900.06.004
- 900.06.005
- 900.06.007
- 900.06.008

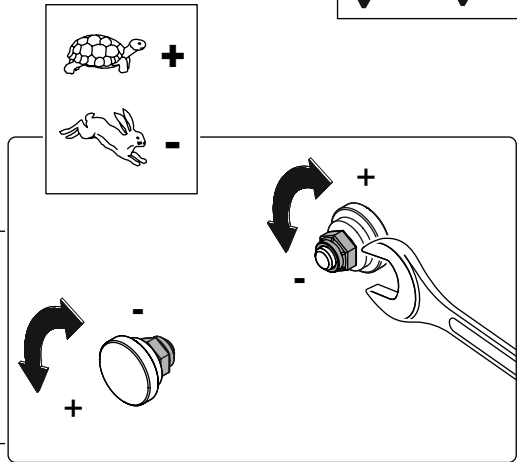
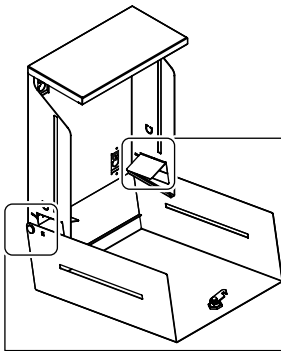
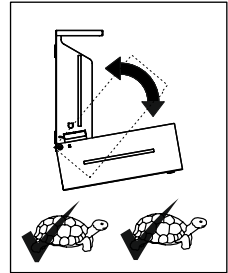

Refill

900.06.005
900.06.007
900.06.008

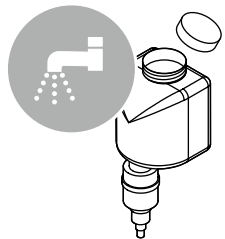
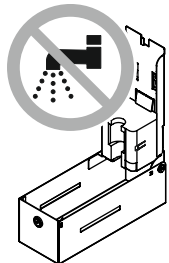
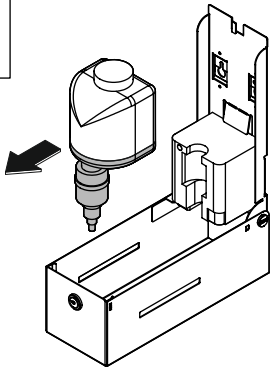

1

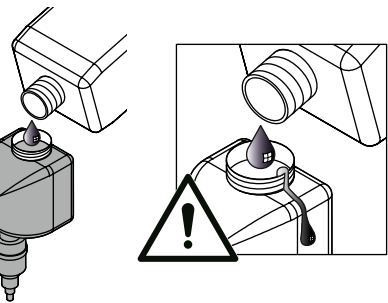

2

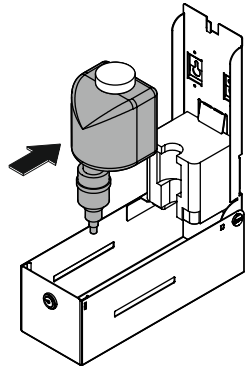

3

Optional

900.06.004

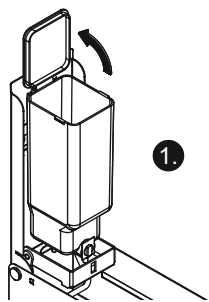

1

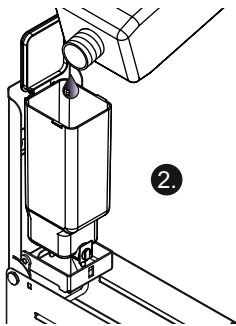

2

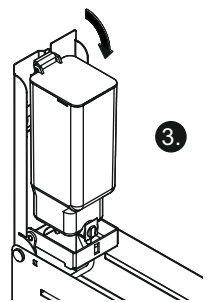

3

1

Battery

900.06.005
900.06.007
900.06.008

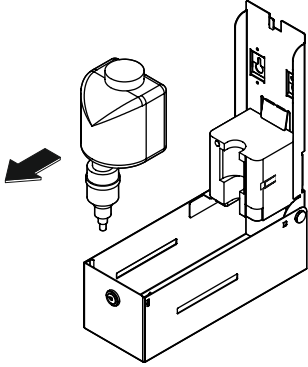

1

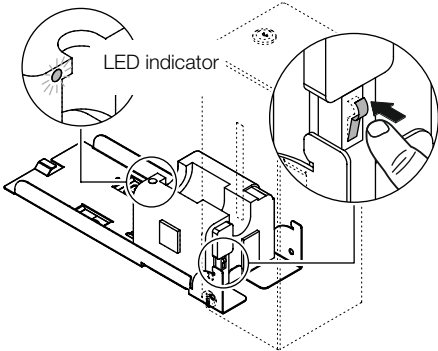

2

Check

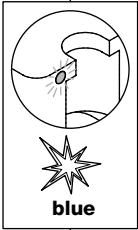
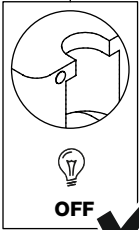
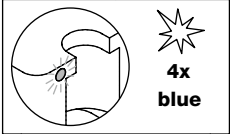

Replace

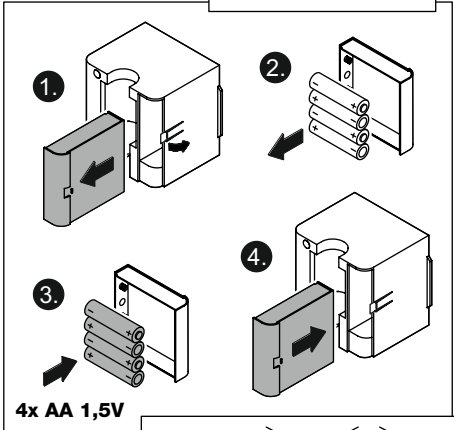

3



HEWI



GERMANY

HEWI Heinrich Wilke GmbH

Prof.-Bier-Straße 1-5

D-34442 Bad Arolsen

Phone: +49 5691 82-0

Fax: +49 5691 82-319

international@hewi.de

www.hewi.com

UNITED KINGDOM

HEWI (UK) Limited

Holm Oak Barn, Beluncle Halt

Stoke Road, Hoo

Rochester, Kent ME3 9NT

info@hewi.co.uk



M9000.30

2025/03