

FR Garniture pour mitigeur thermostatique THG avec deux robinets d'arrêt ref. 5400AE avec boîtier d'encastrement

EN Trim for THG thermostat with 2 valves, -ref. 5400AE with box for rough parts

CN THG恒温混合阀带有两个截止阀ref.5 400AE，带有嵌入式安装盒

DE Garnitur für Unterputz-Thermostat THG, Ref. 5400AE 3/4», mit Absperrventil

ES Parte exterior del termostático con dos llaves de paso integradas (para ref 5400AE con caja de emportar)

IT Guarnizione per valvola miscelatrice termostatica THG con due rubinetti di arresto rif.5 400AE con scatola da incasso

NL Pakking voor thermostatische mengkraan THG met twee afsluitkranen ref.5 400AE met inbouwbehuizing

RU Гарнитура для терmostатического смесителя THG с двумя запорными кранами арт.5 400AE с корпусом для встройки

AR تجهيزات إضافية للخلاط المنظم للحرارة THG مع صنبورين للغلق الرمز المرجعي 5400AE مرفق بصندوق الدمج

Outillage (fourni)

Tools (included)

工具

Werkzeug (mitgeliefert)

Herramientas (proporcionadas)

Attrezzatura (fornita)

Bevestiging inclusief

непредоставляемые инструменты

أدوات (مزودة)



Outillage (Non-fourni)

Tools (Not provided)

工具 (自备)

Werkzeuge (Nicht mitgeliefert)

Herramientas (no suministradas)

Utensili (non forniti)

Gereedschap (Niet meegeleverd)

инструменты (Не обеспечен)

الأدوات (غير مرفقة)

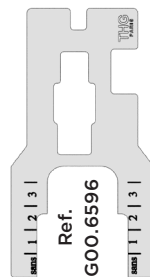
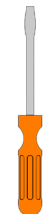

ou
or
或
oder
o
o
of
или
أو

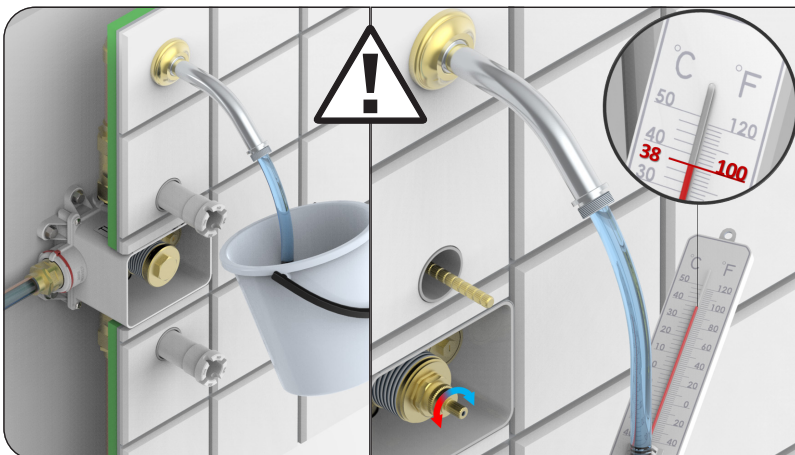
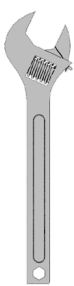

Assurez vous d'avoir purgé les canalisations et vérifié l'étalonnage de la cartouche

Make sure you have purged the water pipes, and checked the calibration of the cartridge

确保已清空管道并检查滤芯的校准

Stellen Sie sicher, dass Sie die Kanäle gespült und die Kalibrierung der Kartusche überprüft haben

Asegúrese de que ha limpiado los conductos y verificado la calibración del cartucho

Assicurarsi di aver spurgato le condutture e controllato la calibrazione della cartuccia

Zorg ervoor dat u de leidingen hebt ontluicht en de kalibratie van de cartouche hebt gecontroleerd

Убедитесь, что вы прочистили трубопроводную сеть и проверили калибровку картриджа

تشو وطرخ للآري اعمر نمر ققحت و تاونقلا ري هطت نمر دكأت

5400AE

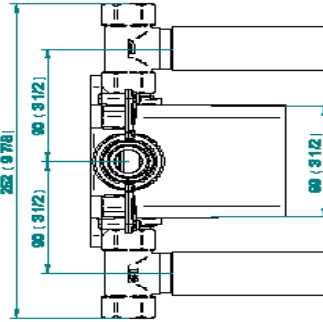
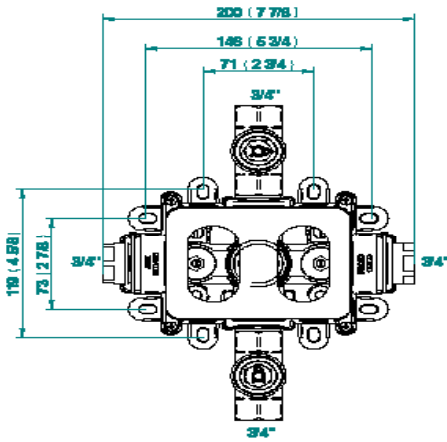
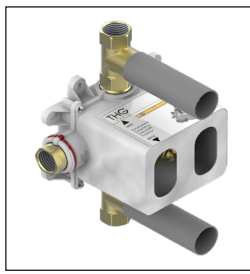

Encastrement Mini Mini flush-mount

Cache épaule	Rosace à fût
X = 74mm	X = 97mm
Toute les séries (Yoko et Beyond y compris)	G3R - G3S - G3T - G3U - G3V - G3W - G7K - U2K - U7G - U7H - U7J - U7K - U7L - U7M - U7N - U7P - U7S - U7T - U6F - U6G - U6H - U6J - U6K

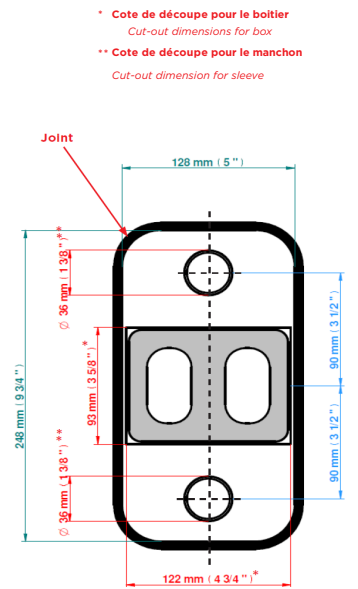
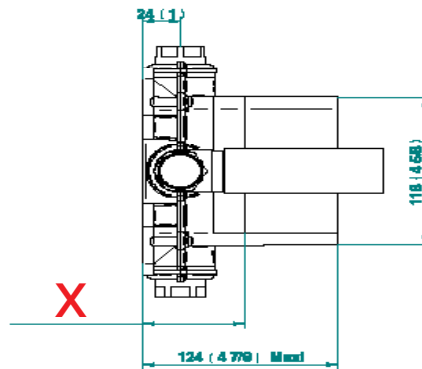

Installation / Installation / 安装 / Installation / Instalación / Installazione / Installatie / Установка / التركيب

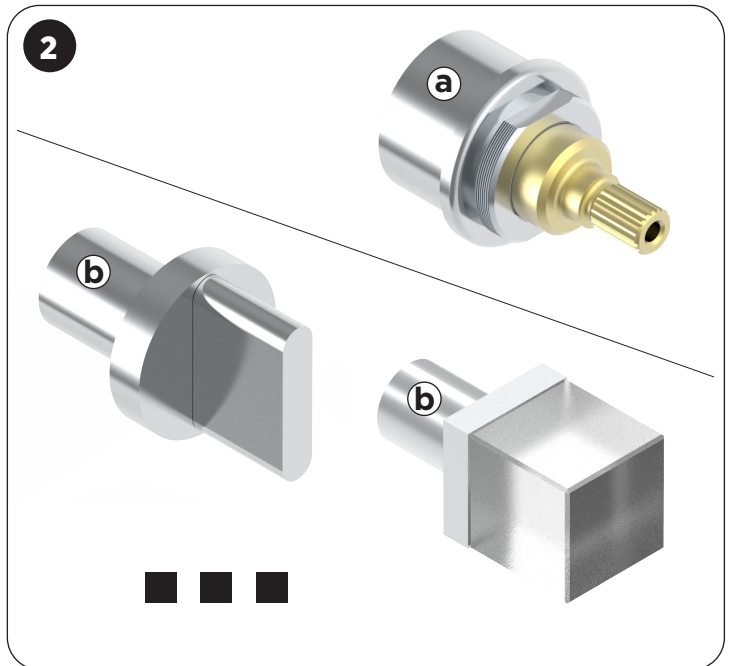
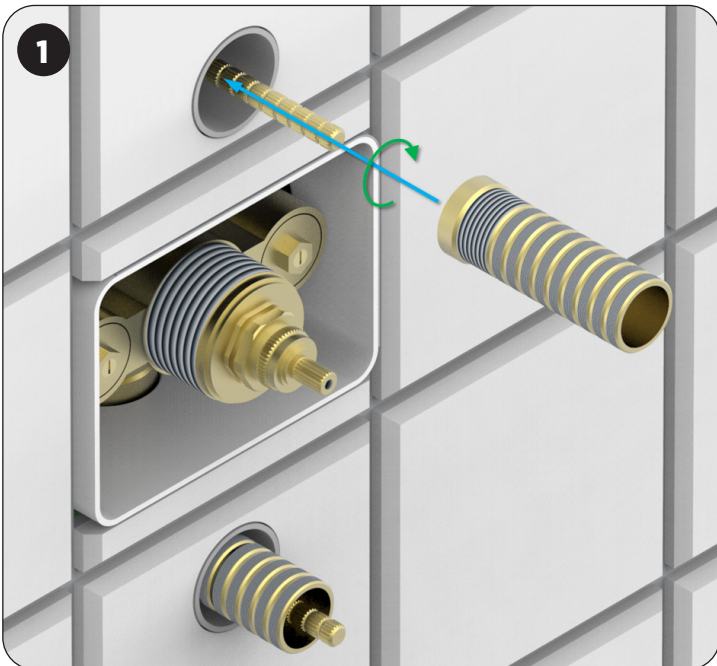

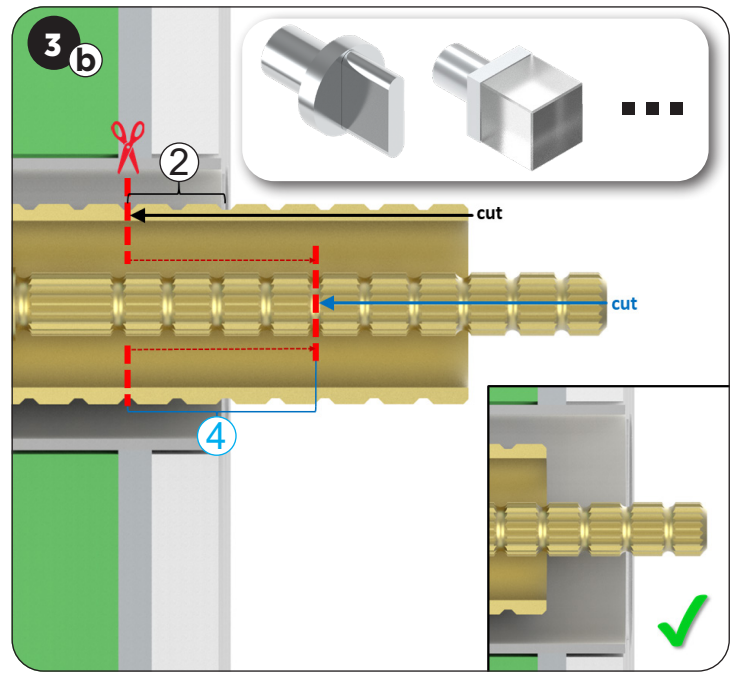
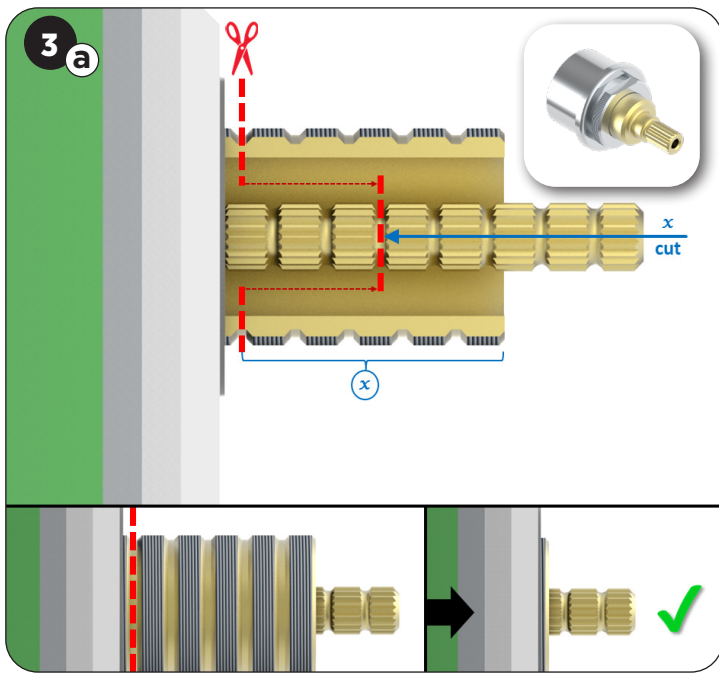

Decoupe special pour la serie Beyond

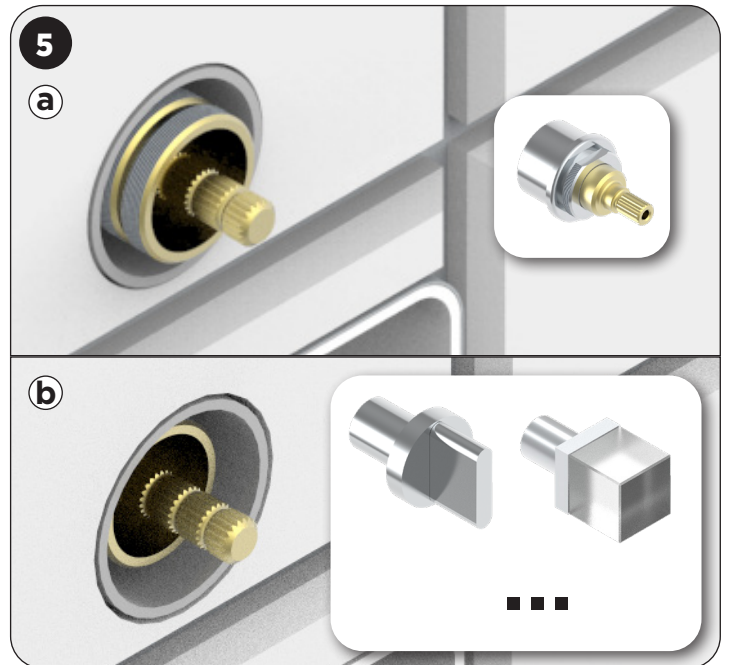
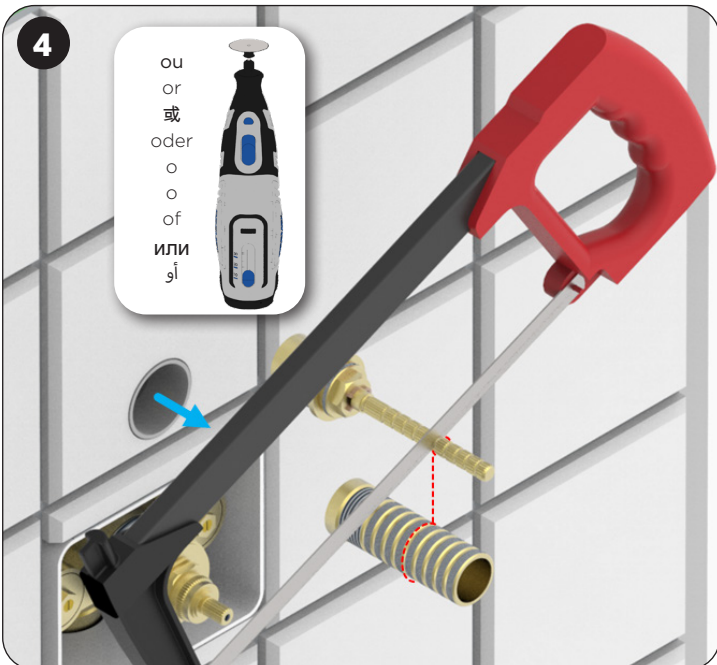
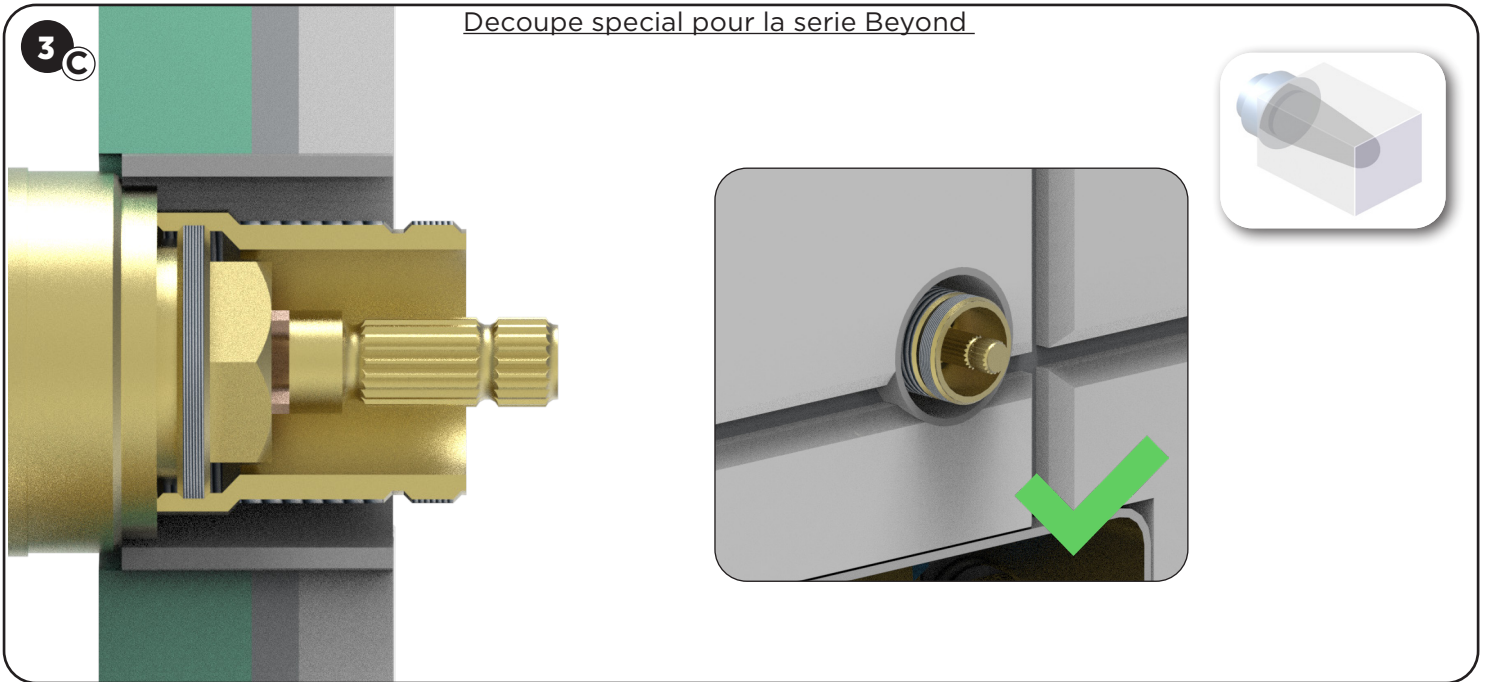

Montage avec cache epaule

Mounting with shoulder cover

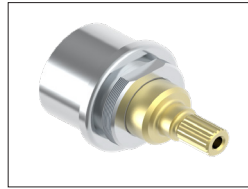

6.1

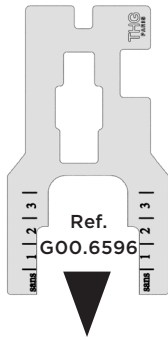

6.2

ou
or
或
oder
o
o
of
или
أو

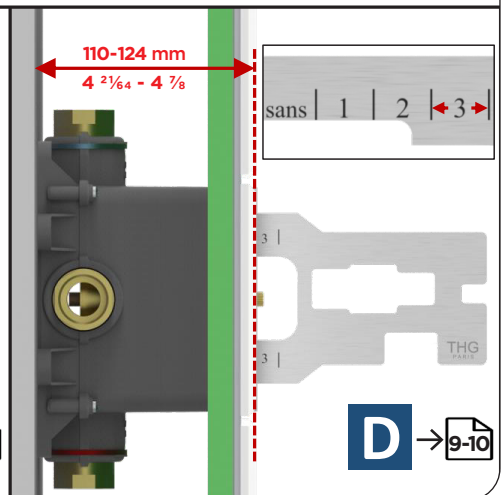
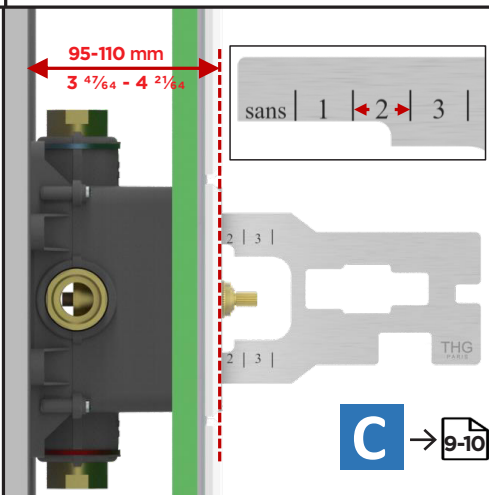
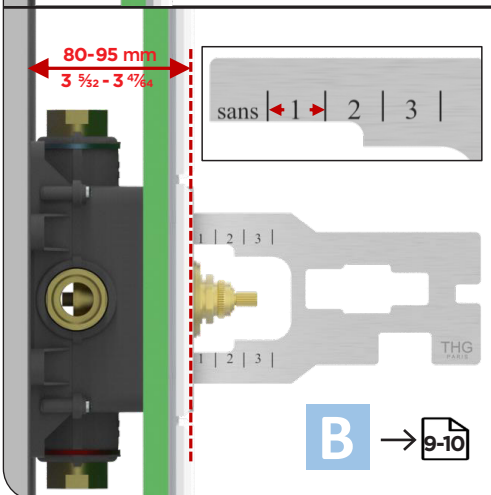
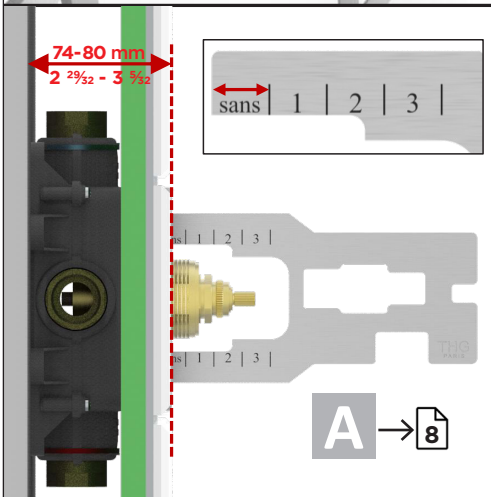
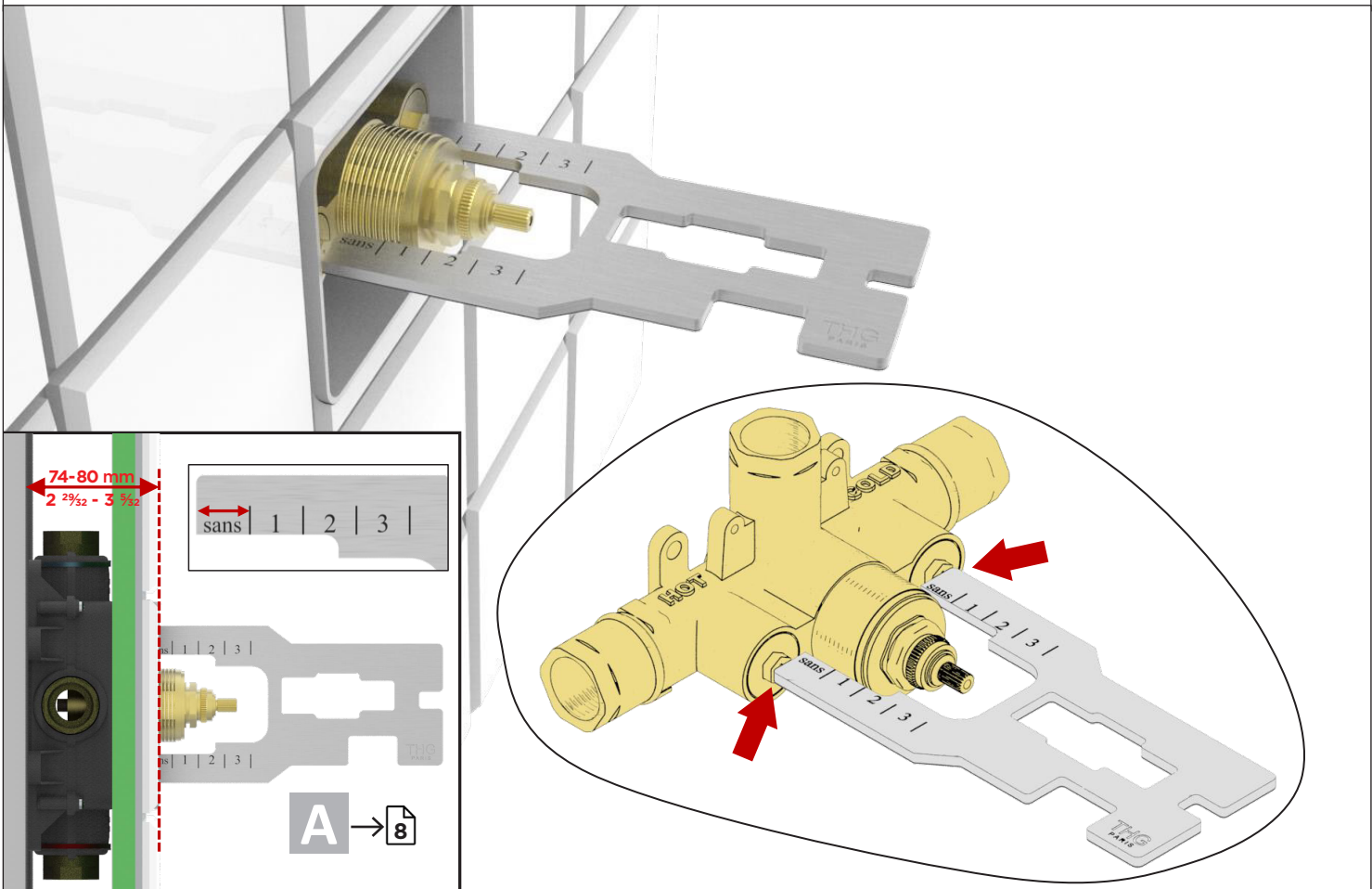
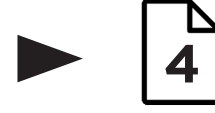

6.2

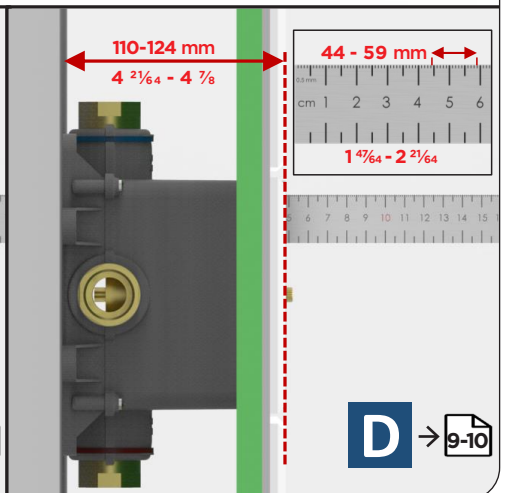
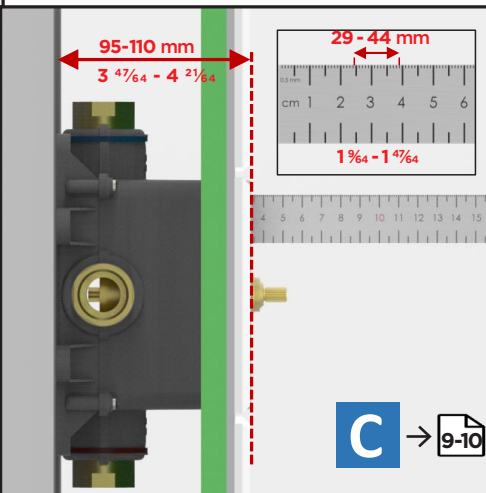
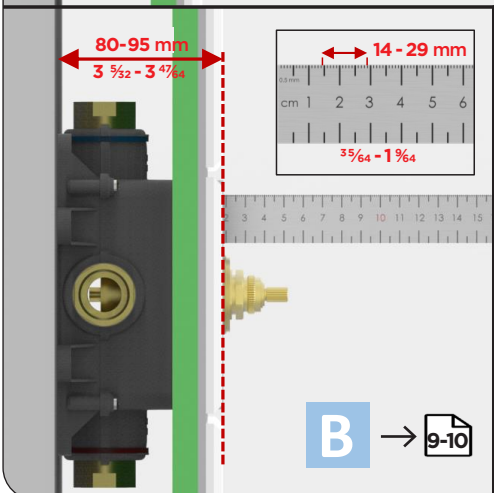
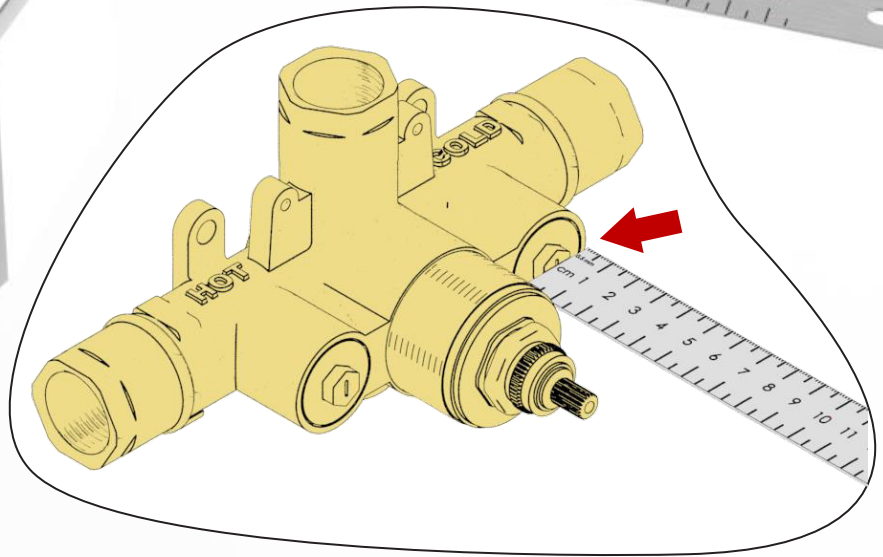
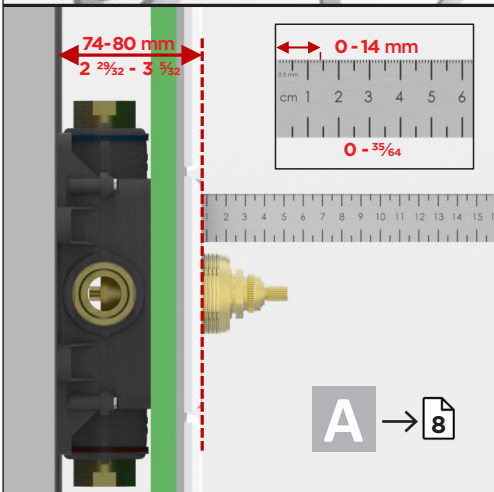
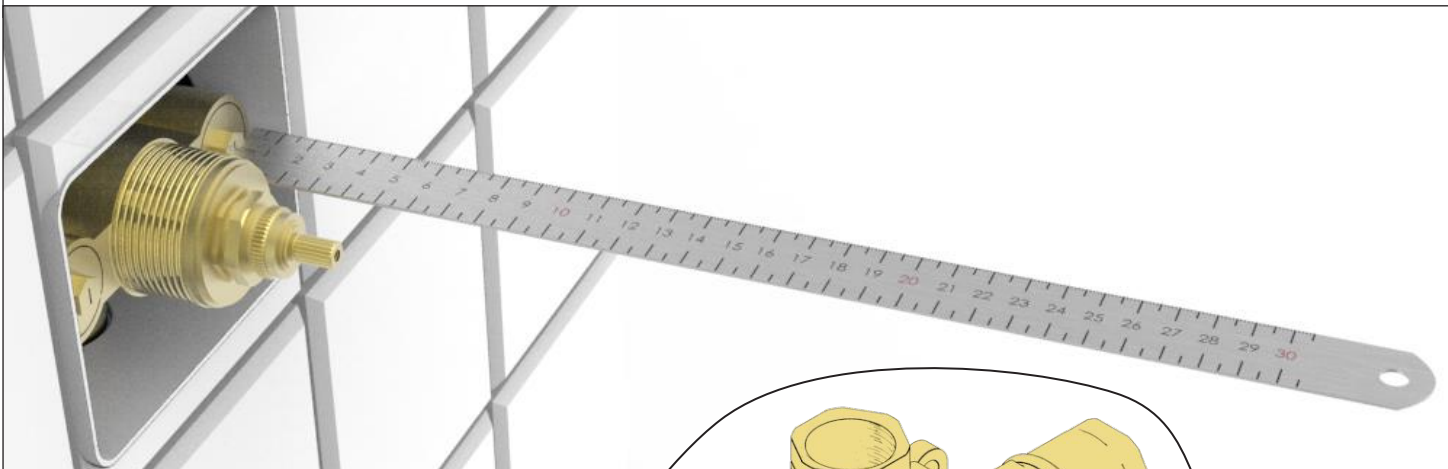

Montage avec fût

Mounting with tube underneath

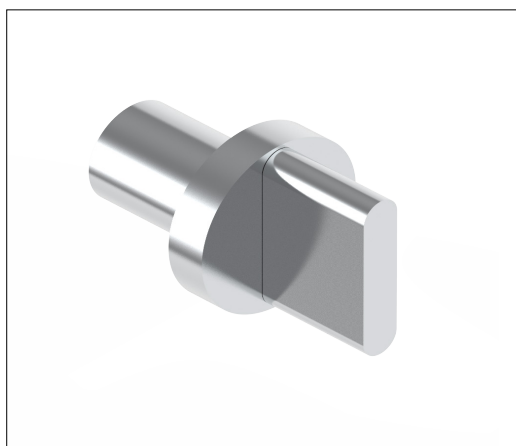

7.1

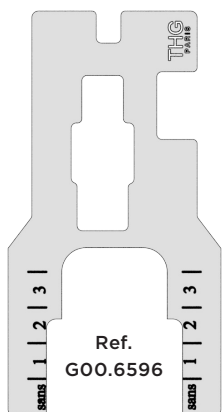

7.2

ou
or
或
oder
o
o
of
или
o

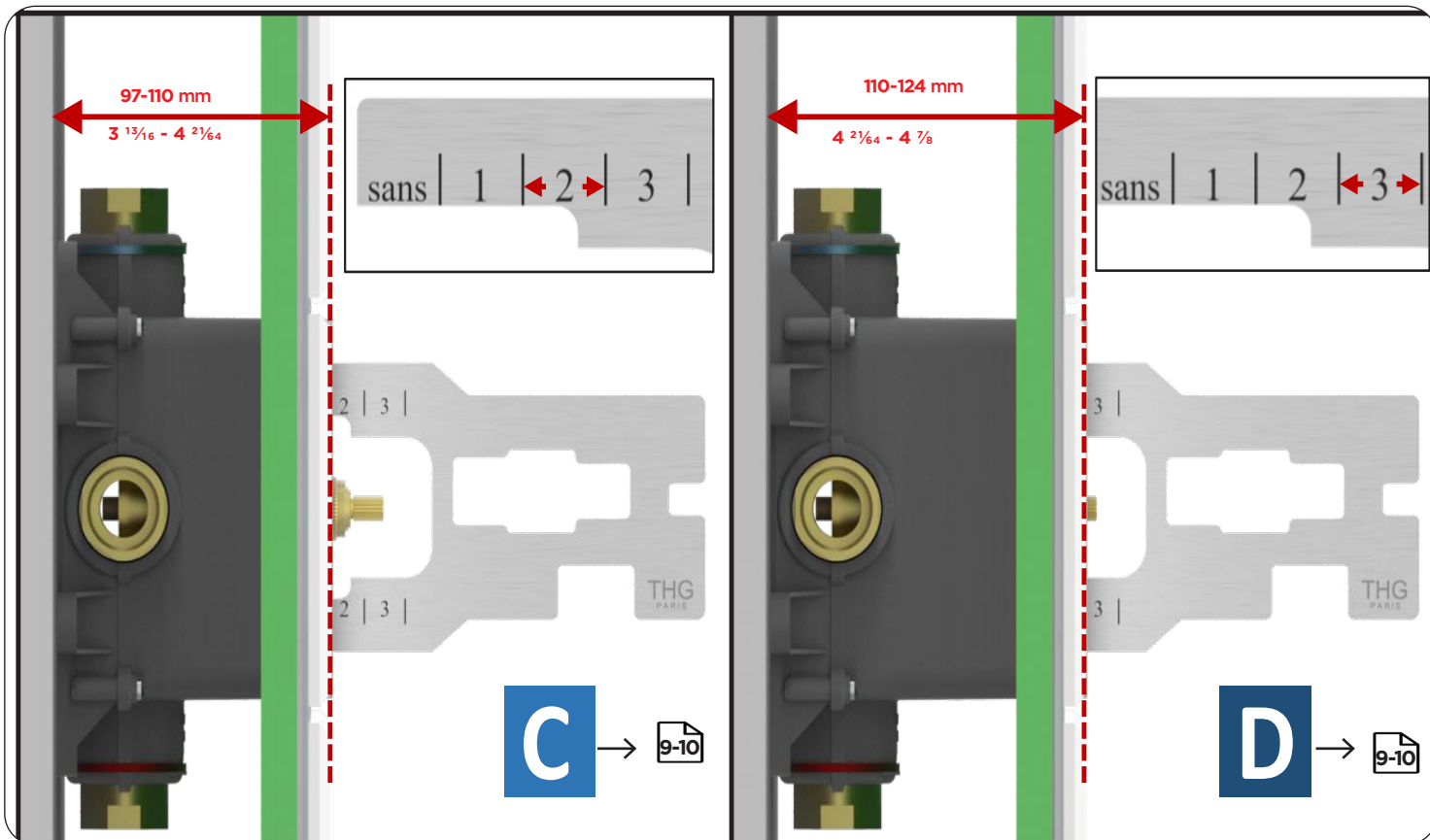

7.2

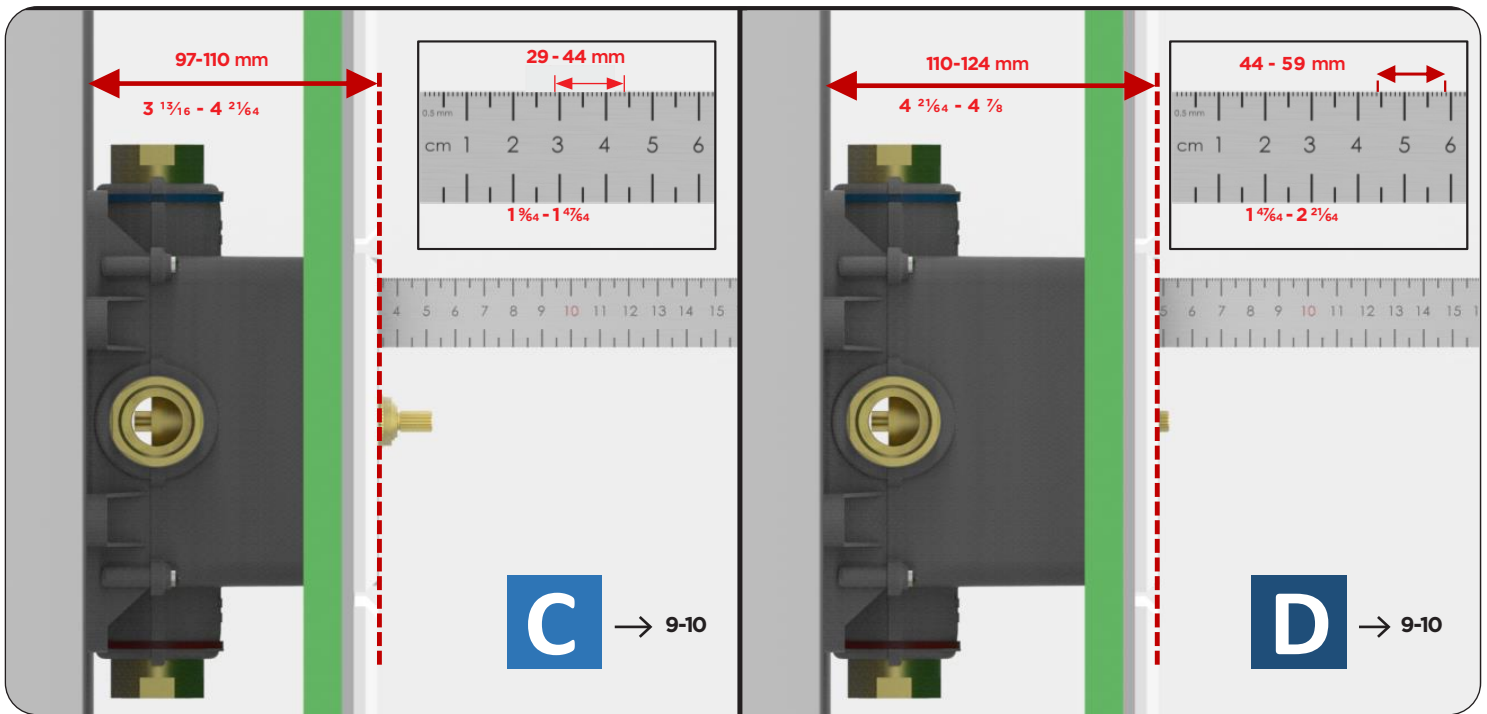
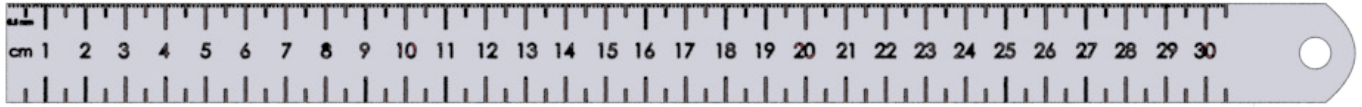

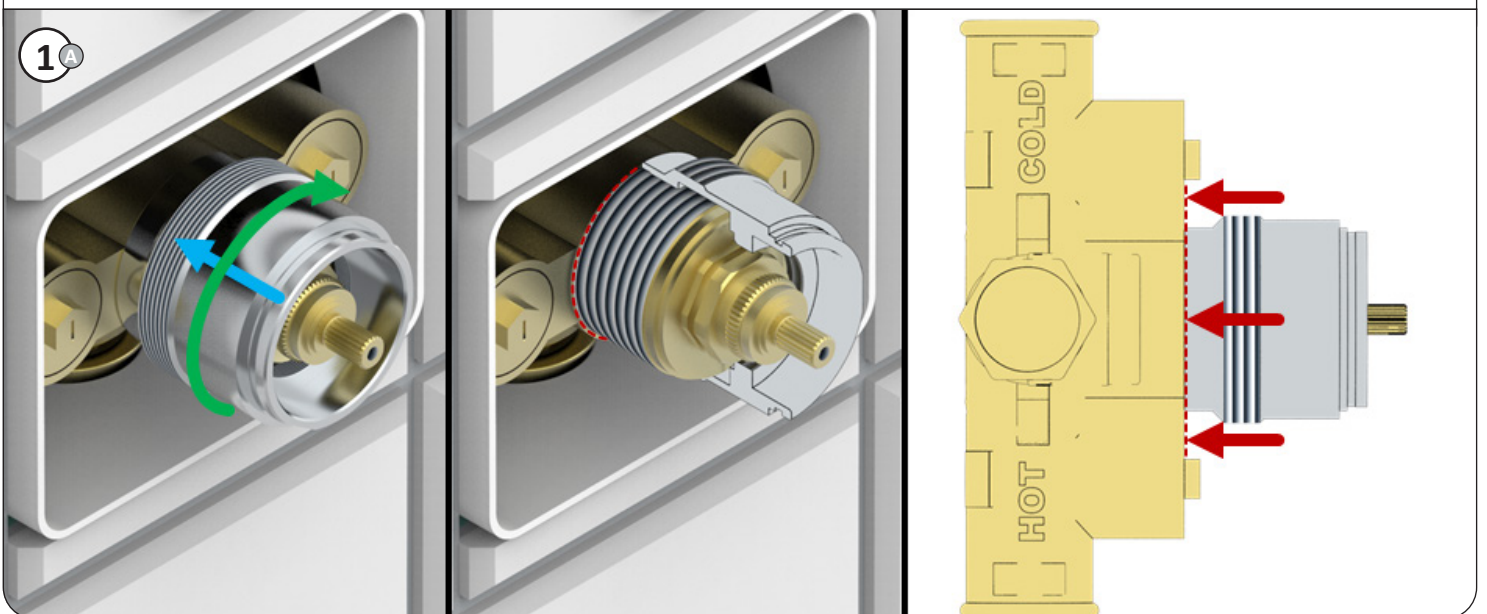
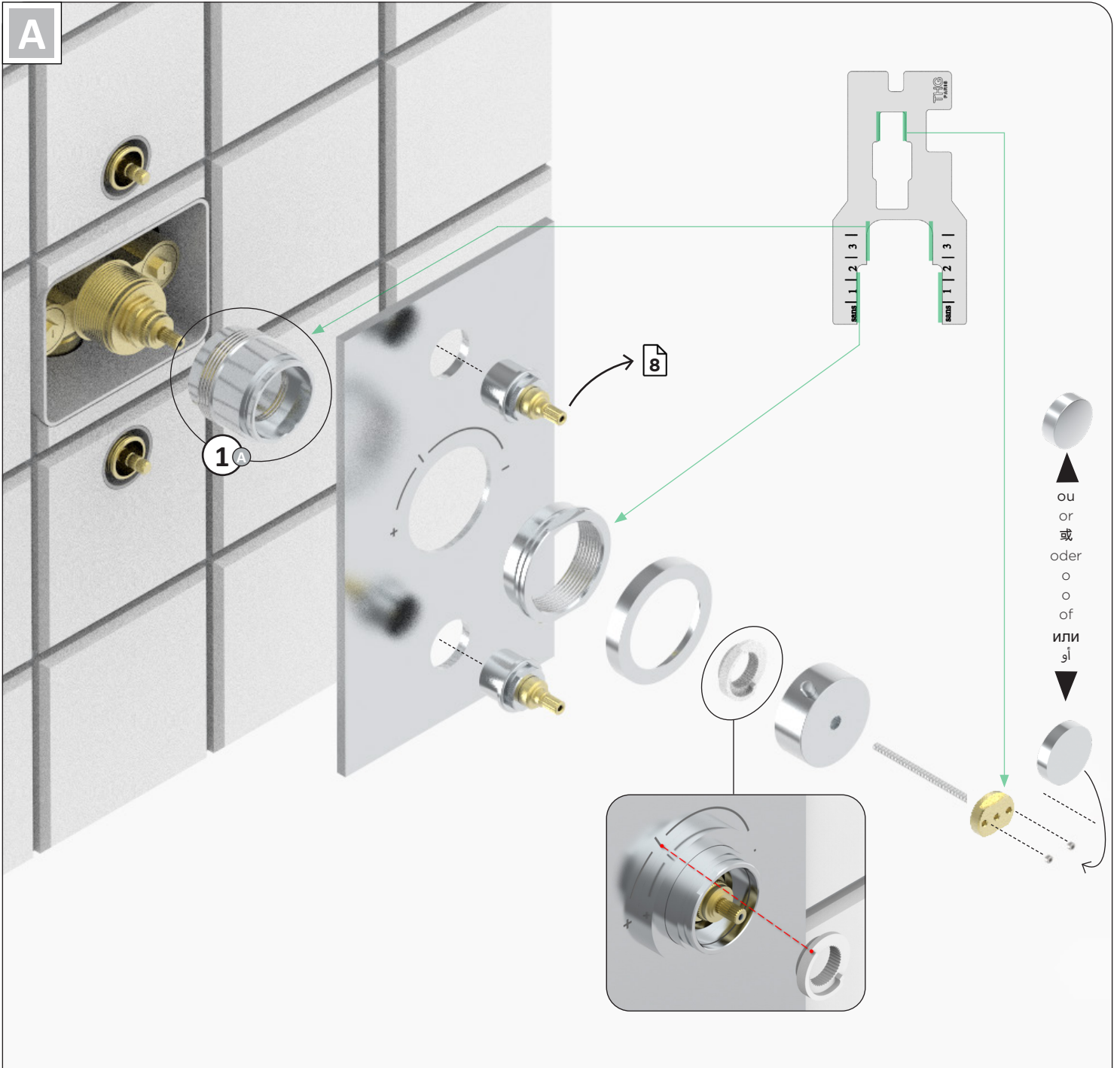

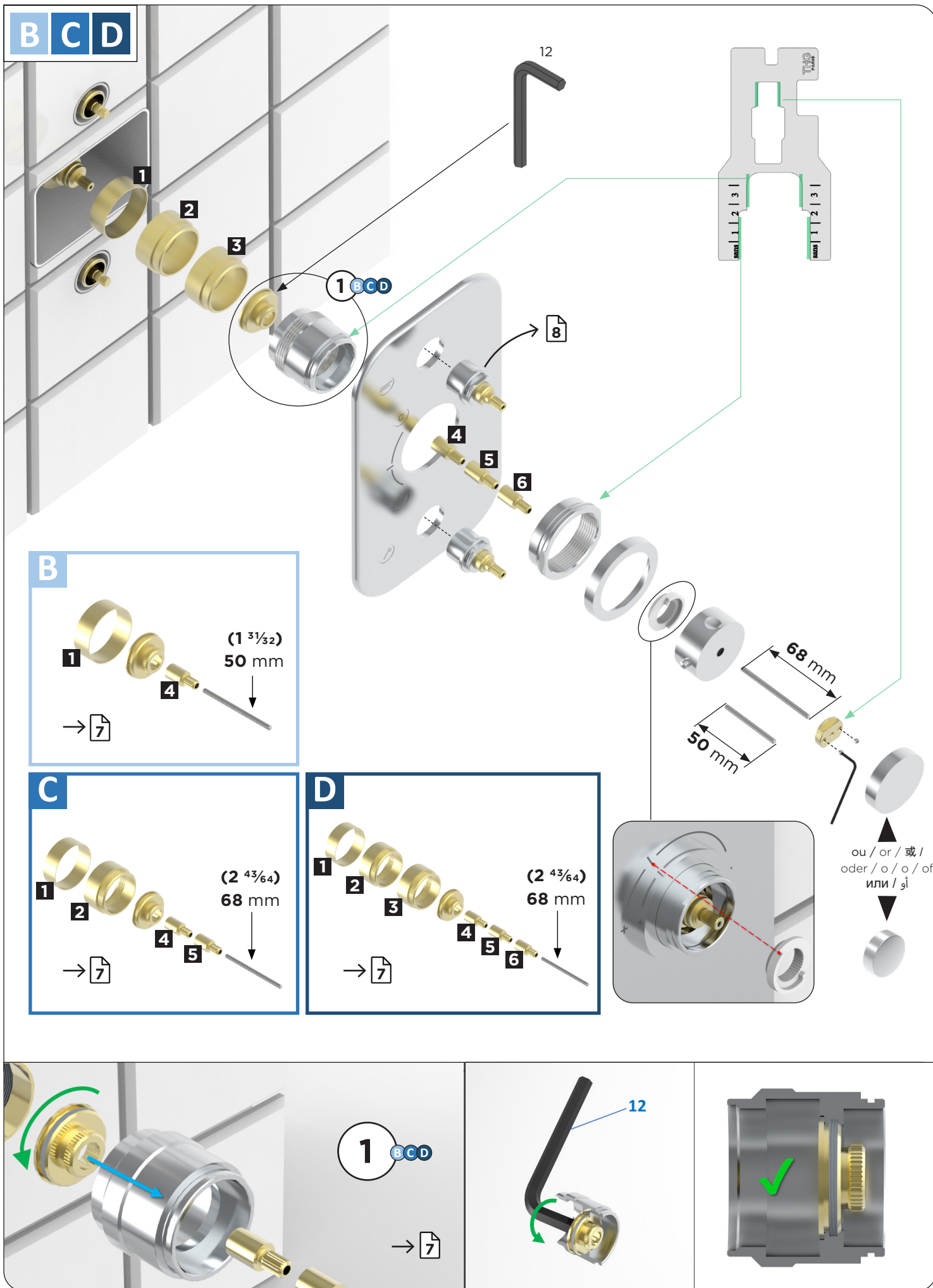

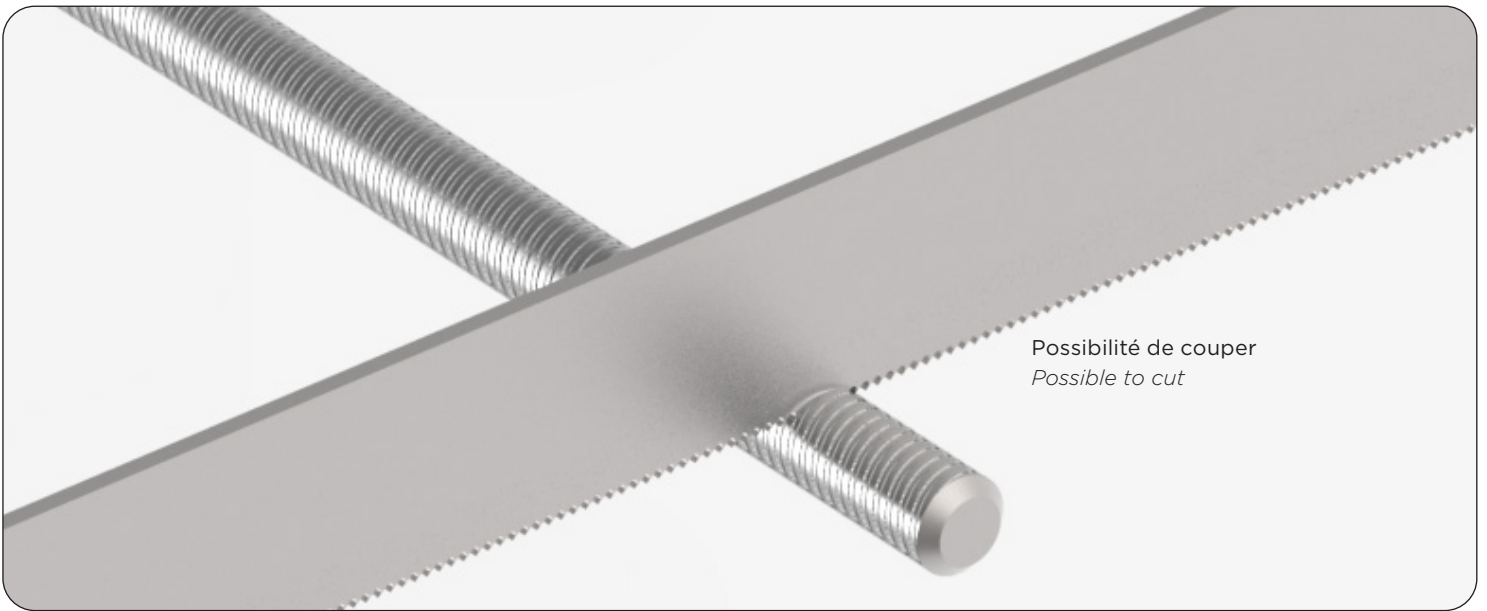

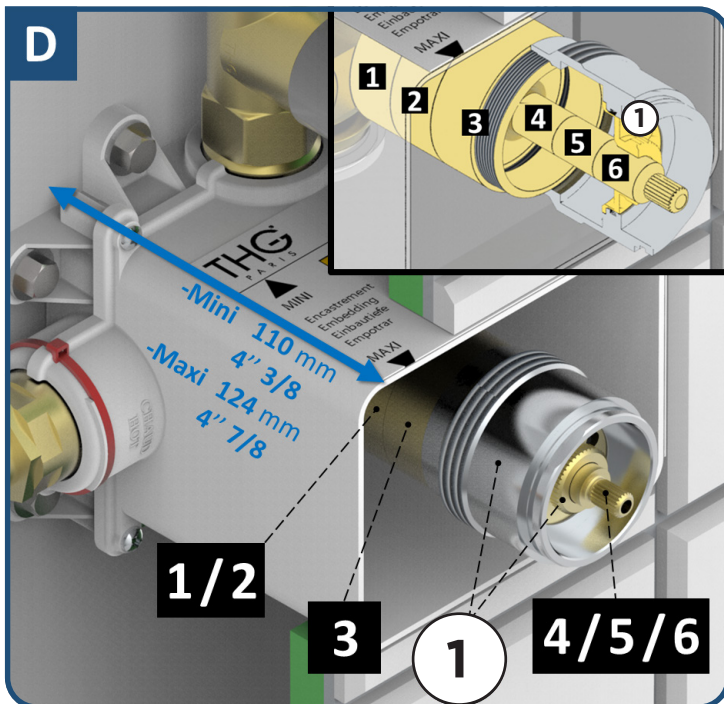
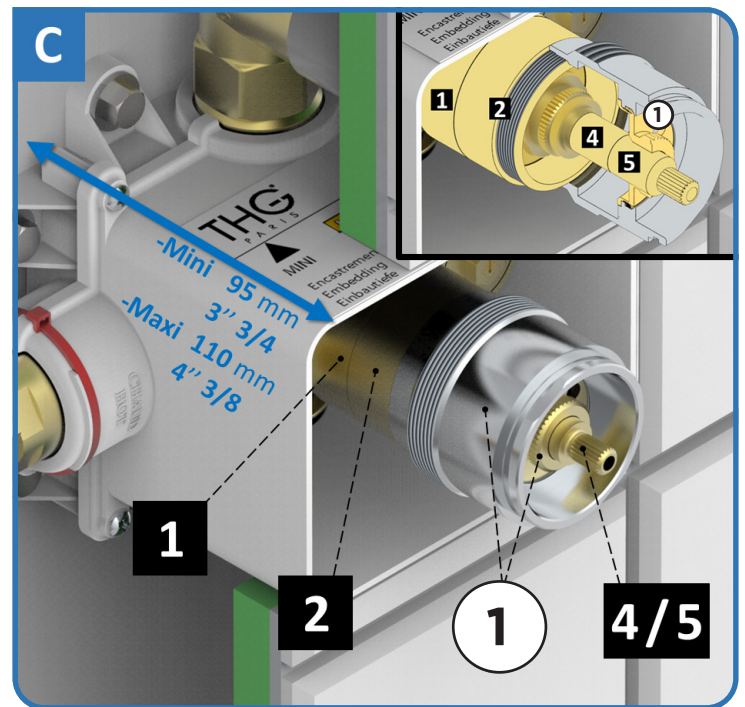
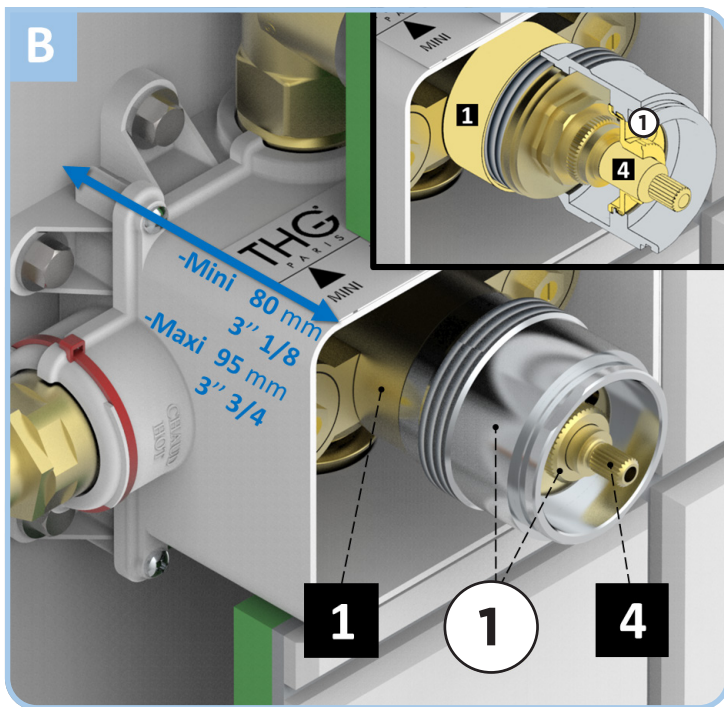

Possibilité de couper
Possible to cut

Montage avec allonges / Assembly with extensions / 带延长件安装 / Montage mit Erweiterungen / Montaje con extensiones /
Montaggio con prolunghe / Montage met verlengstuk / Сборка с расширениями / تركيب بواسطة قطع توصيل



8 a



▼

7 cas possibles
7 possible cases
 7 种可能的案例
 7 mögliche Fälle
 7 casos posibles
 7 casi possibili
 7 gevallen mogelijk
 7 варианта возможны
 7 حالات ممكنة

ou
or
或
oder
o
o
of
или
أو

8 b

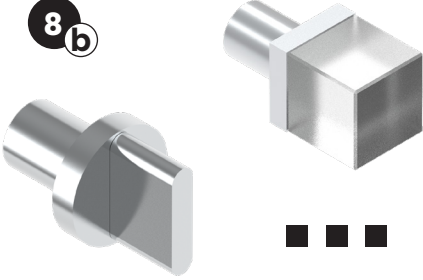

■ ■ ■

▶ 

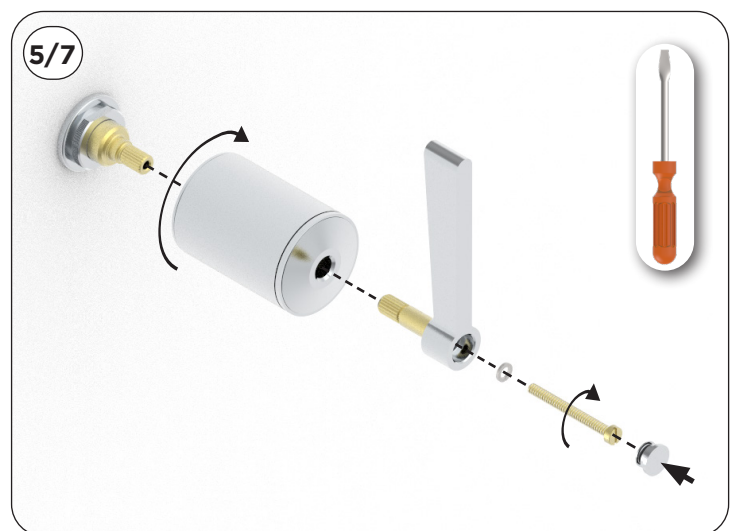
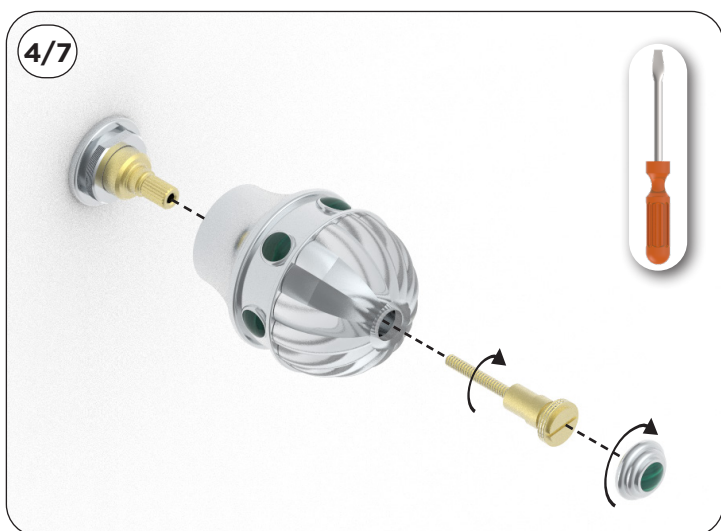
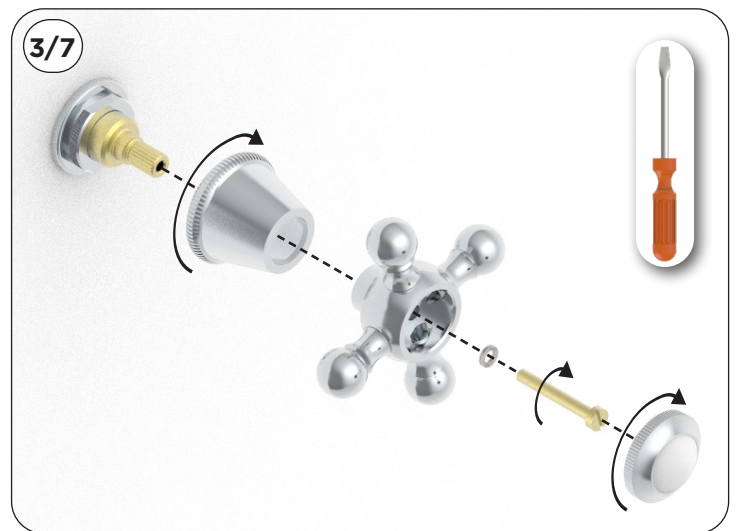
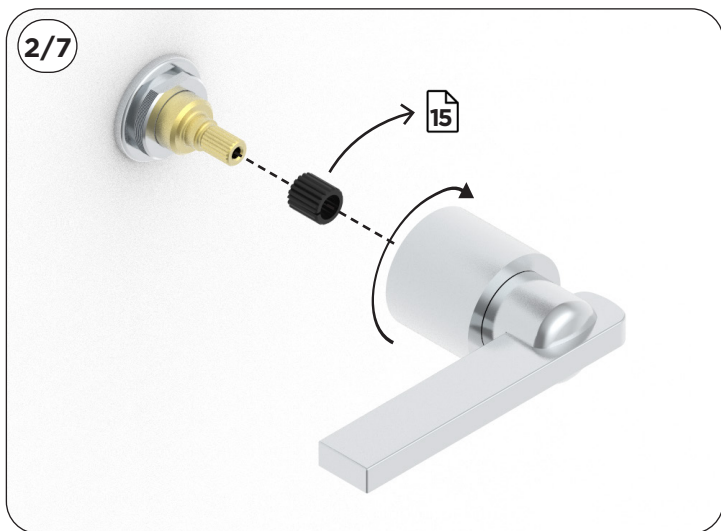
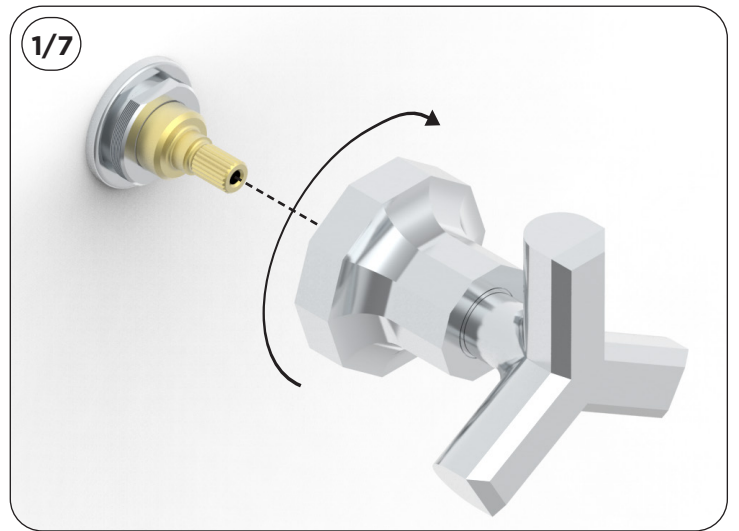

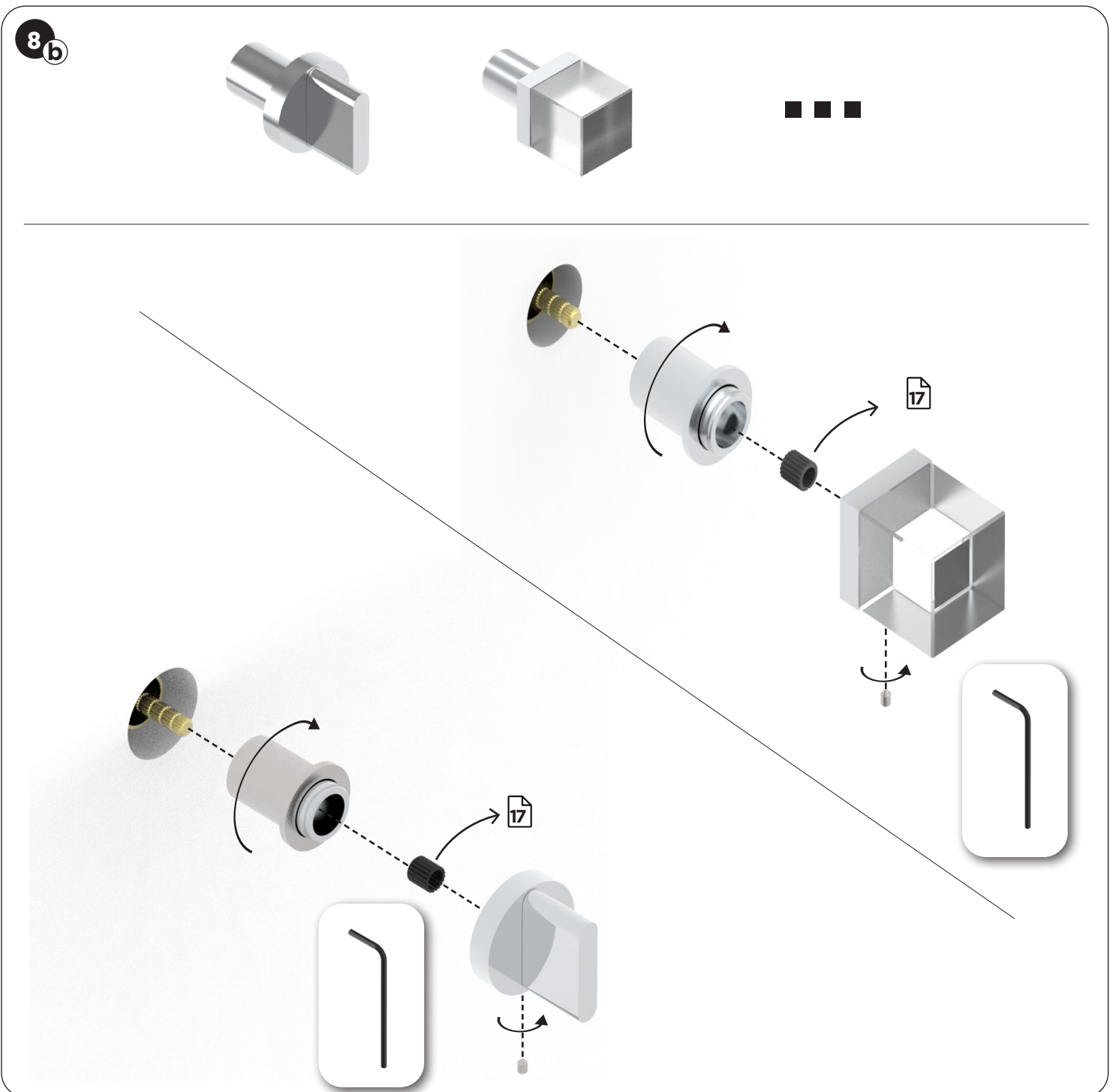
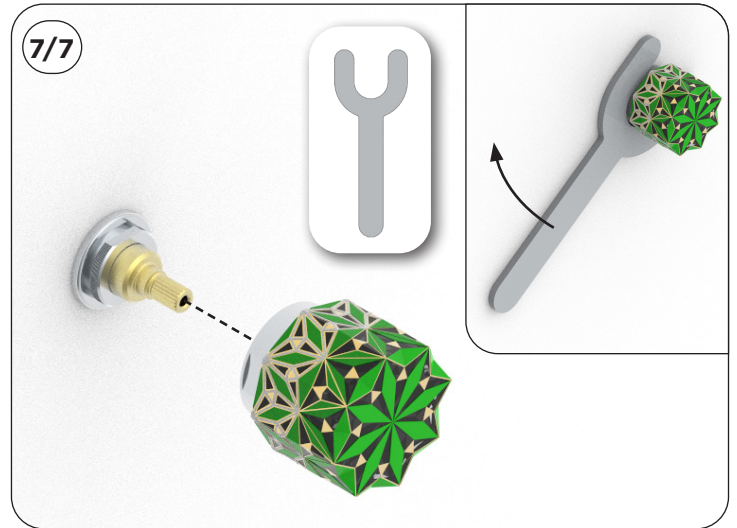
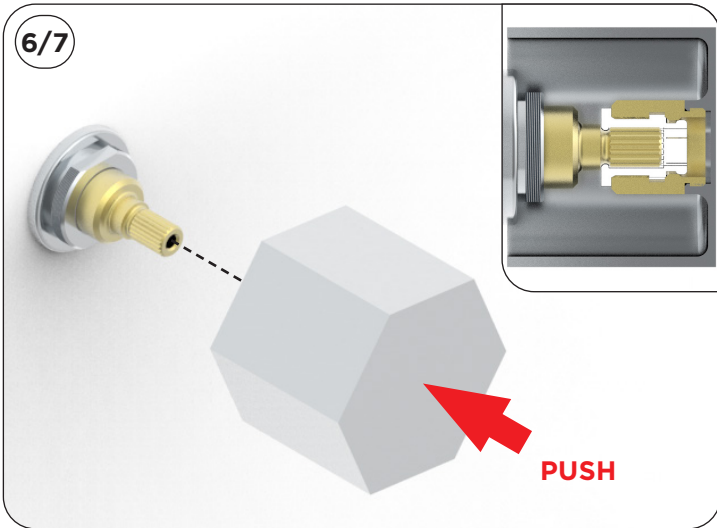

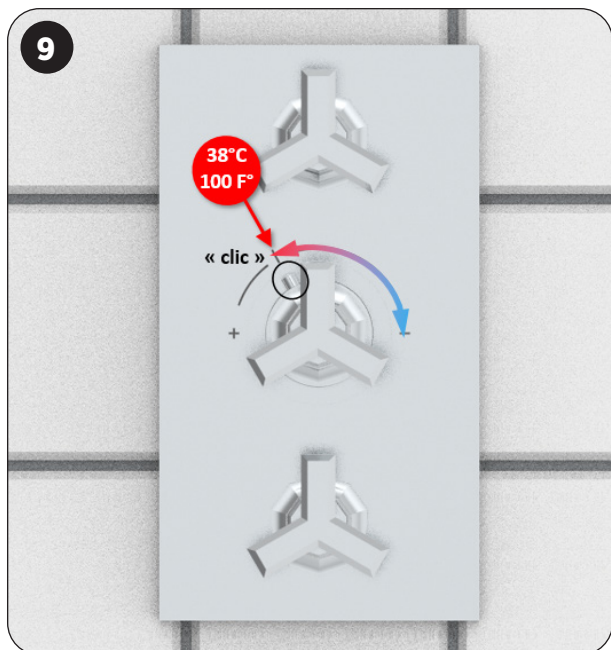

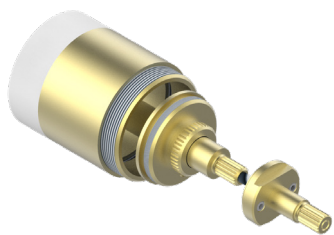

Ref. G00.5100C

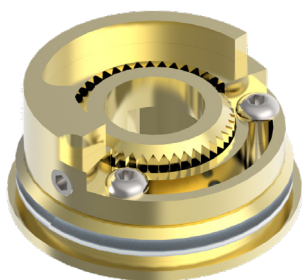

Ref. G00.5100G



Ref. G00.5100H



Ref. G00.6596

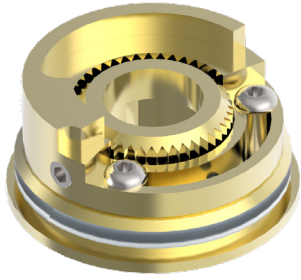

FR Bague de butée renforcée pour thermostatique 5200/5400/5500 avec set de fixation

EN Reinforced stop ring for thermostatic 5200/5400/5500 with fixing set

CN 恒温阀5200/5400/5500的带固定套的止推环

DE Anschlagring, verstärkt, für Thermostat 5200/5400/5500 mit Befestigungsset

ES Anillo de empuje reforzado para termostático 5200/5400/5500 con juego de fijación

IT Anello di spinta per termostatico 5200/5400/5500 con fissaggio

NL Temperatuurstop metaal voor thermostaat 5200/5400/5500 inclusief bevestigingsset

RU Упорное кольцо усиленного Термостатический 5200/5400/5500 с крепежным набором

AR حلقة دعم مُقوّاة من أجل منظم الحرارة ٢٥/٤٠/٥٠ مع طاقم التثبيت

Montage sans allonge / Assembly without extension / 不带延长件安装 / Montage ohne Verlängerung / Montaje sin extensión / Montaggio senza prolunga / Montage zonder verlengstuk / Сборка без расширения / تركيب بدون قطعة توصيل

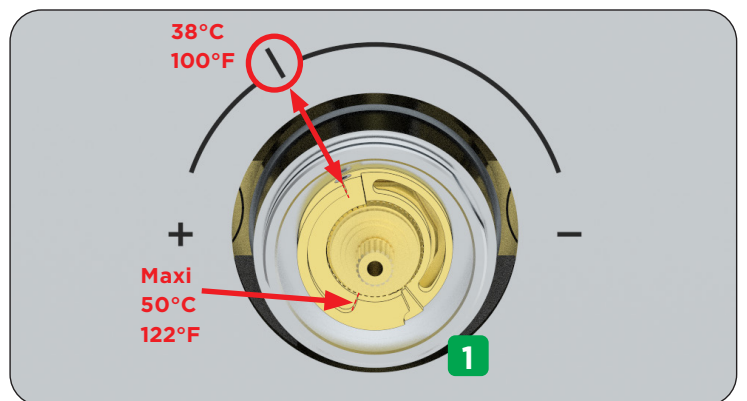
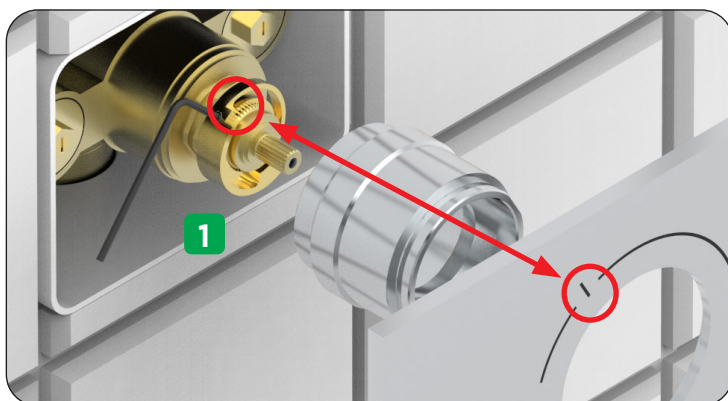
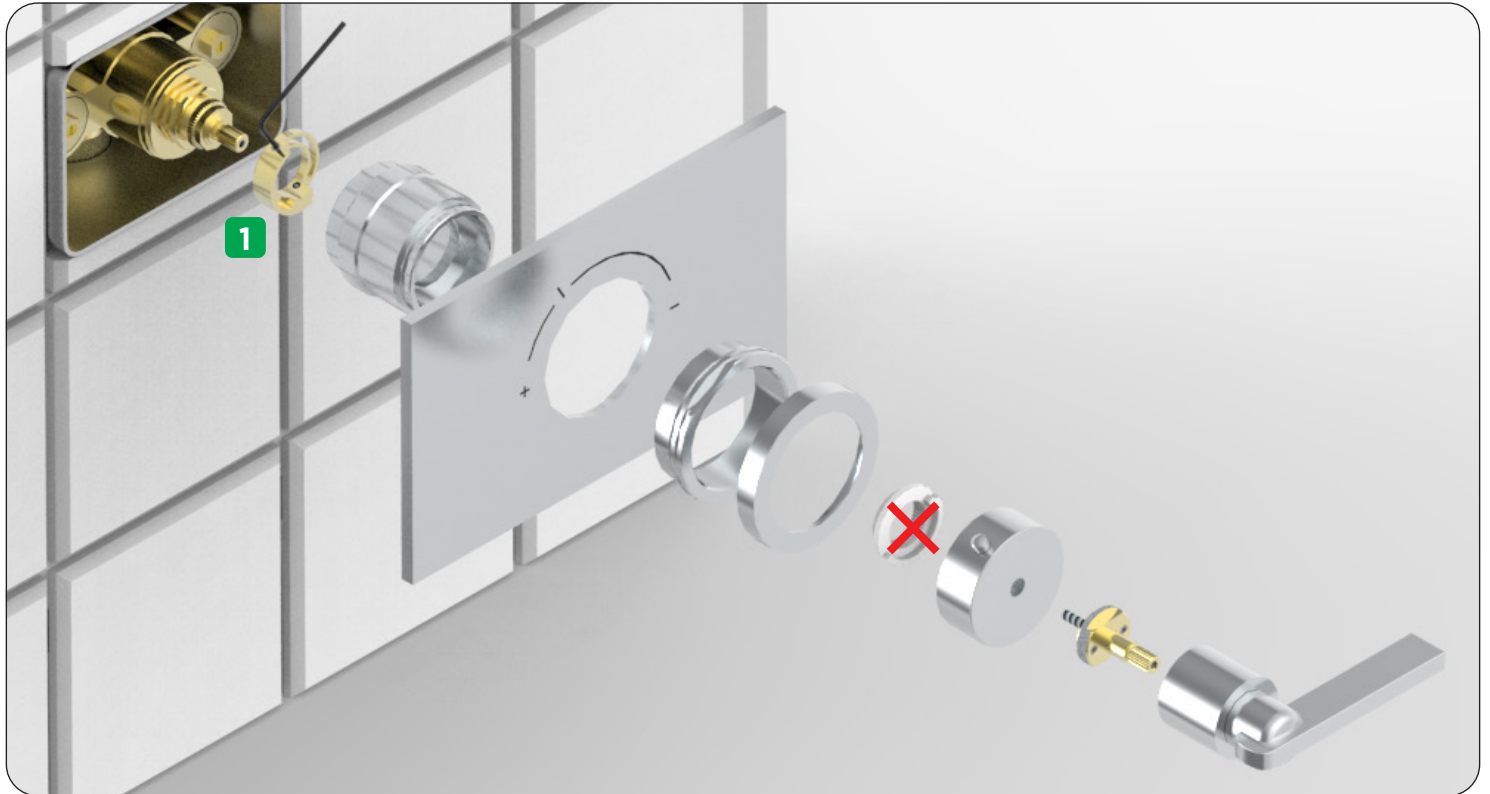

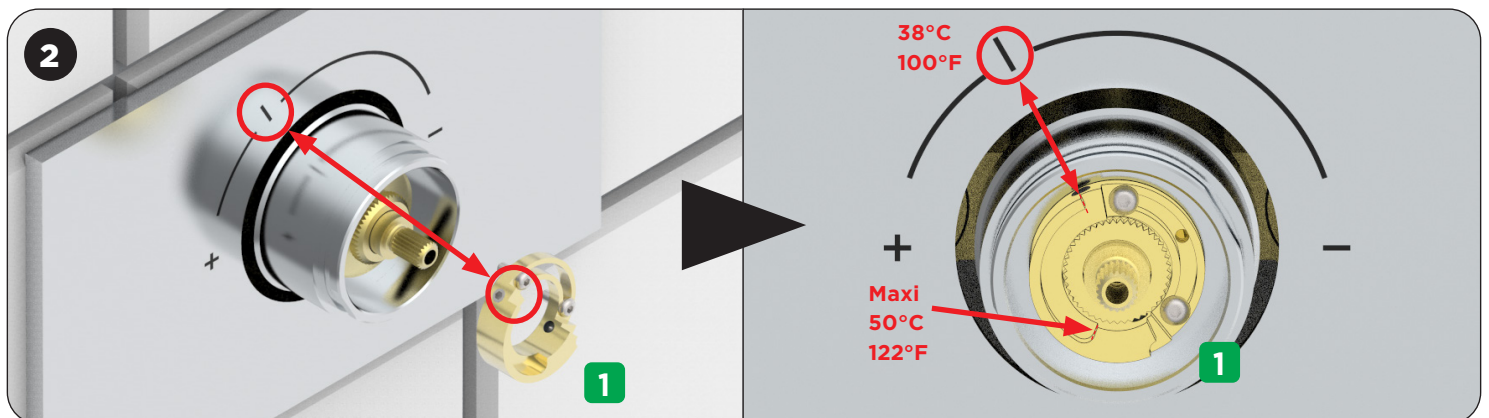
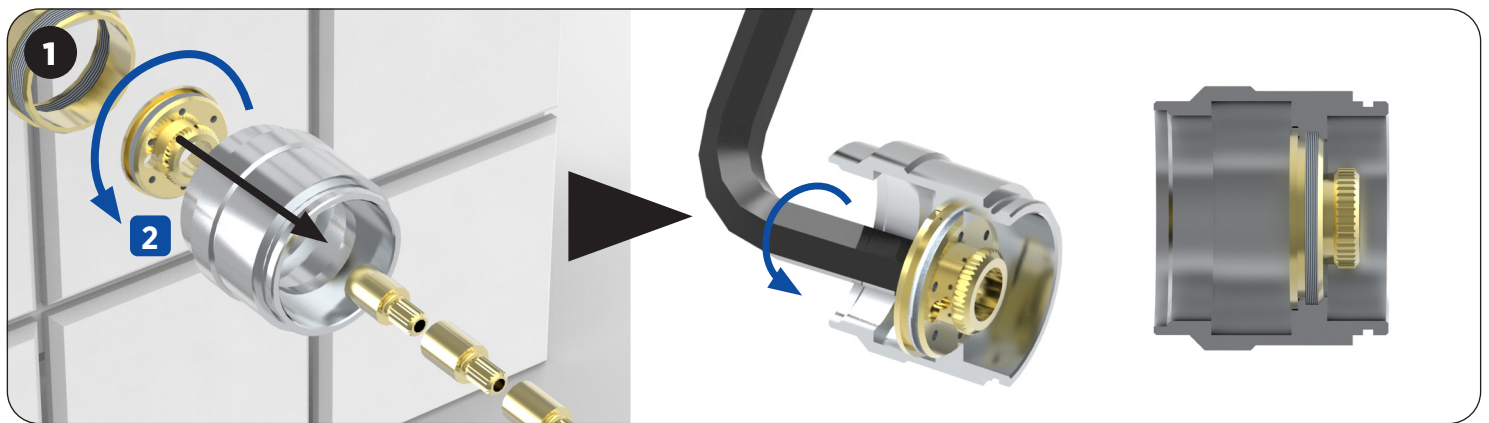
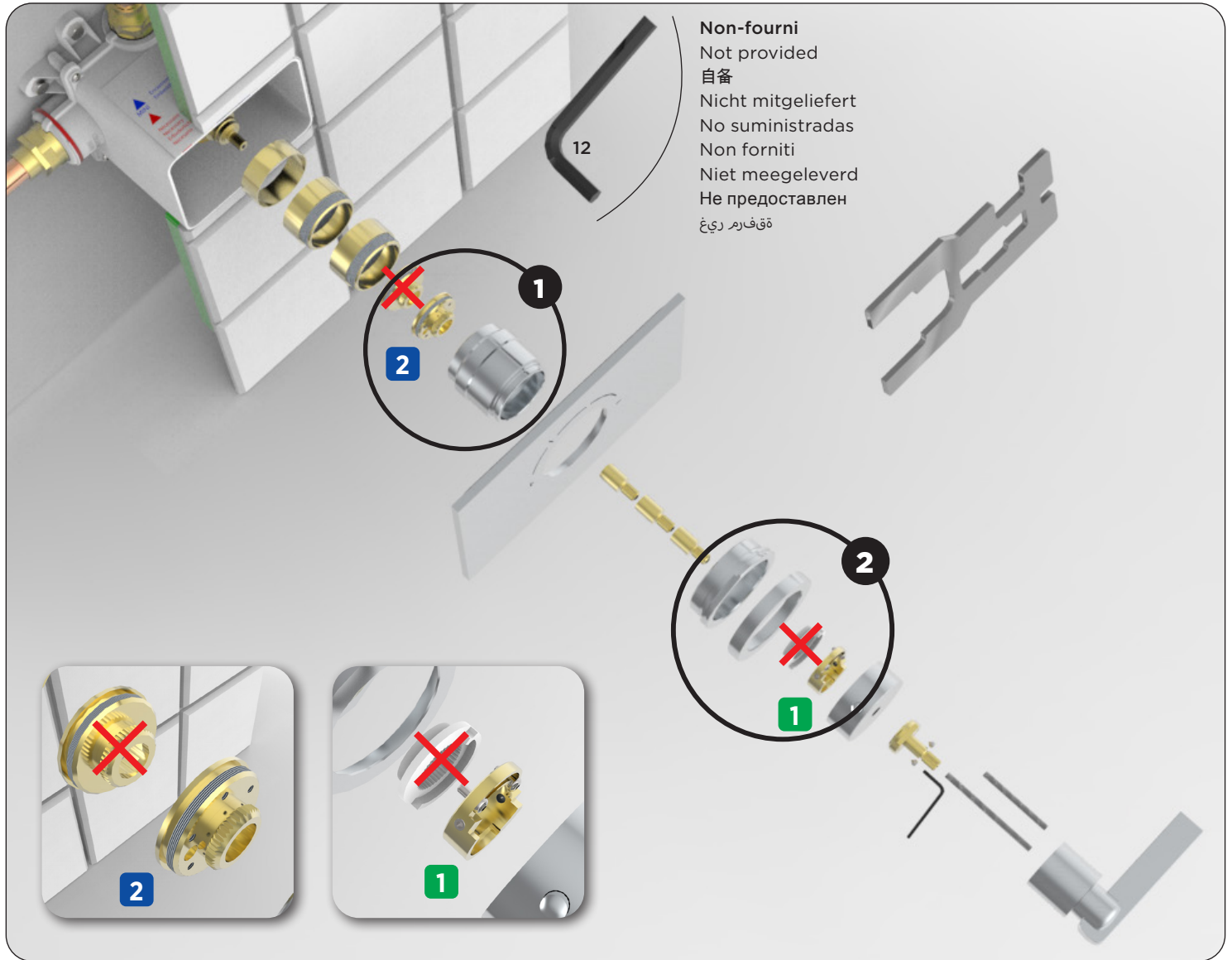

Insert plastique strié

Notice d'installation / Installation instructions / 安装说明 / Installationsanleitung / Instrucciones de instalación / Istruzioni per l'installazione / Installatie handleiding / Инструкции по установке / إرشادات التركيب



- FR** Insert plastique strié
- EN** Grooved plastic insert
- CN** 条纹塑料插件
- DE** Geriffelter Kunststoffeinsatz
- ES** Inserto plástico estriado
- IT** Inserto in plastica striata
- NL** Gegroefde kunststof inleg
- RU** Пластиковая рубчатая прокладка

ملحق بلاستيكي مُحزَّر **AR**

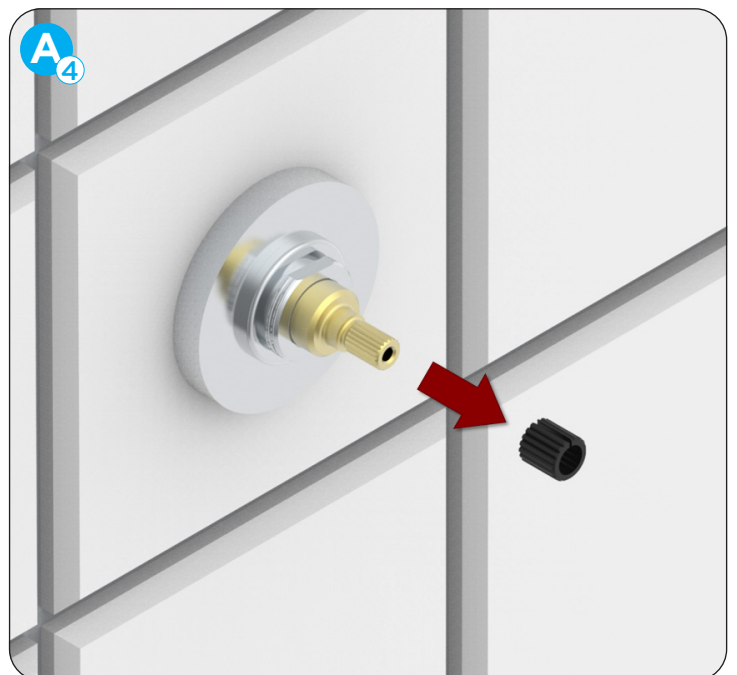
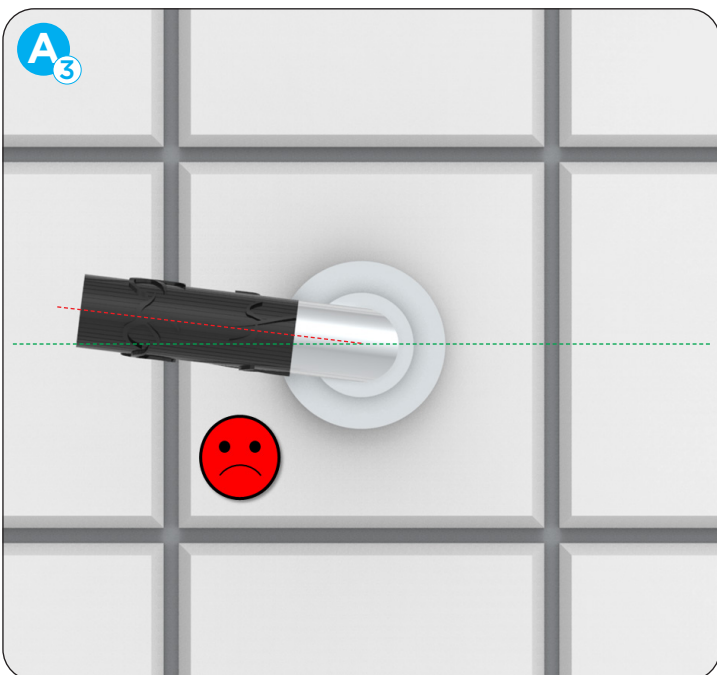
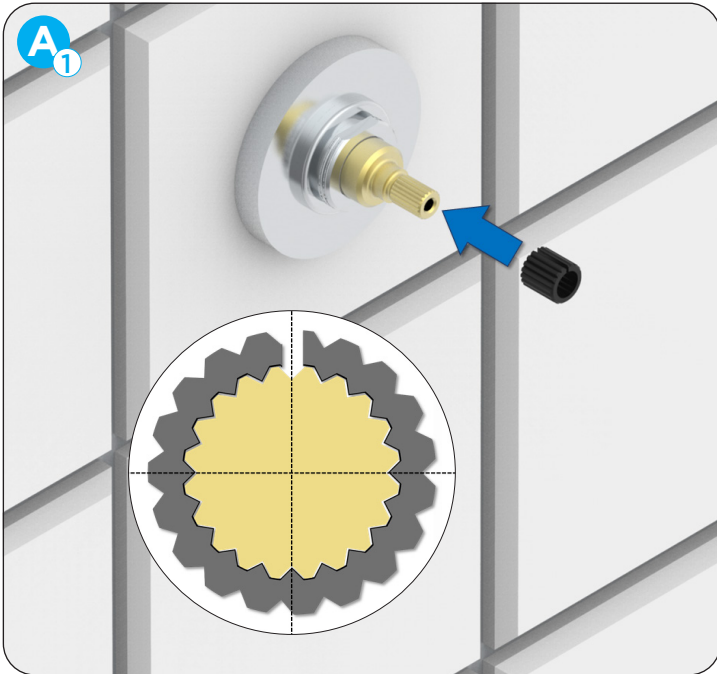

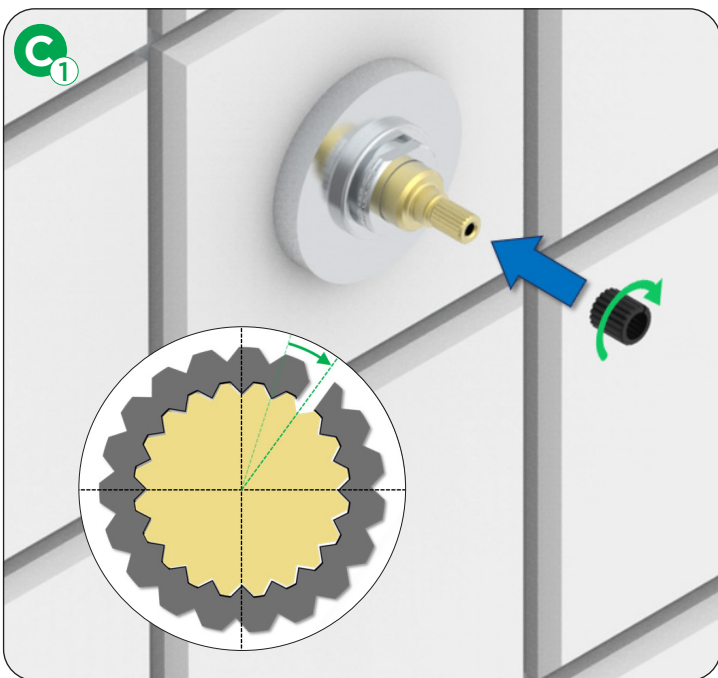
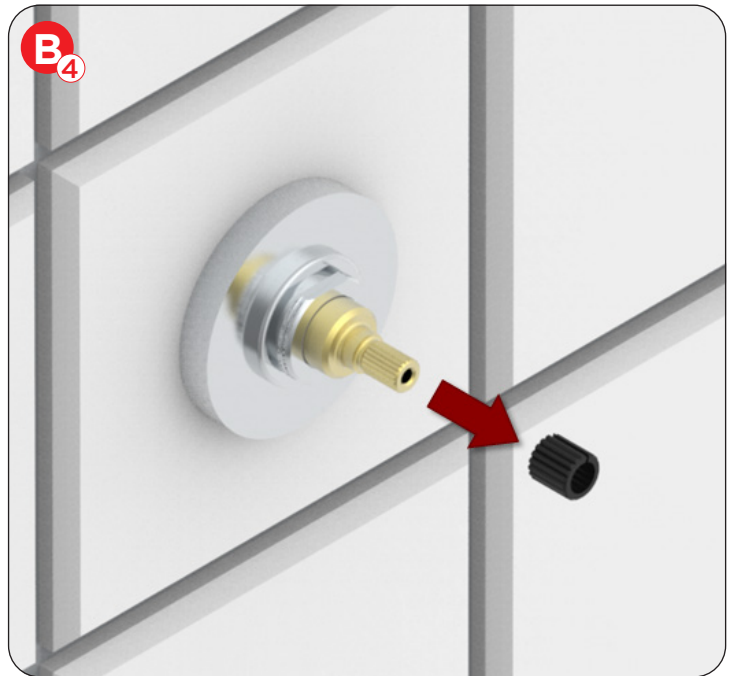
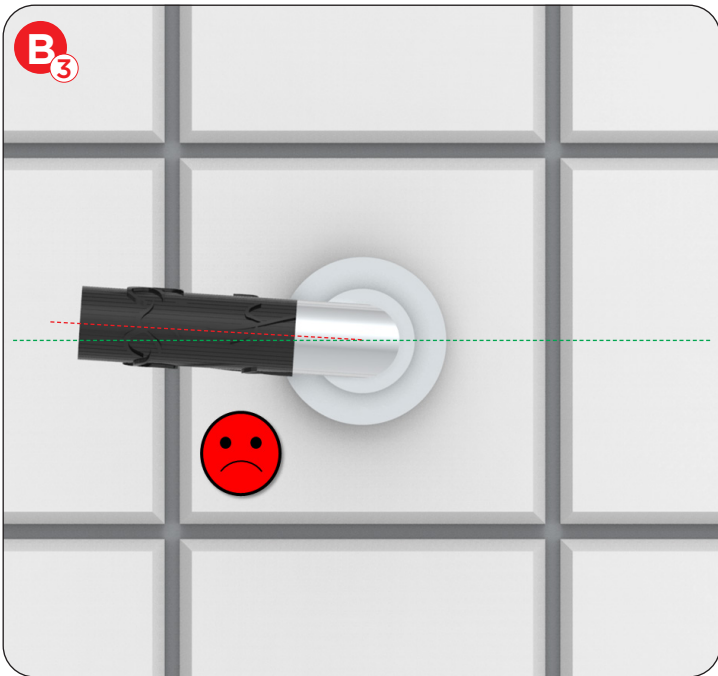
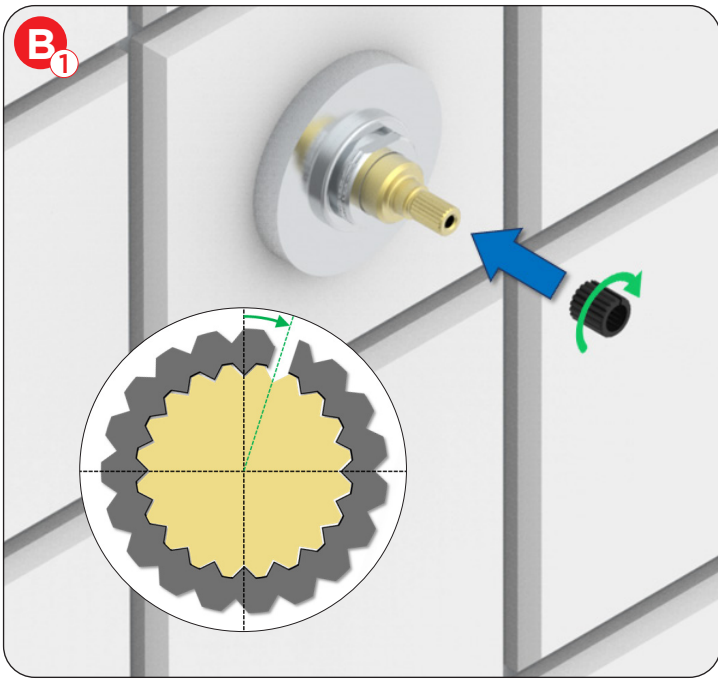

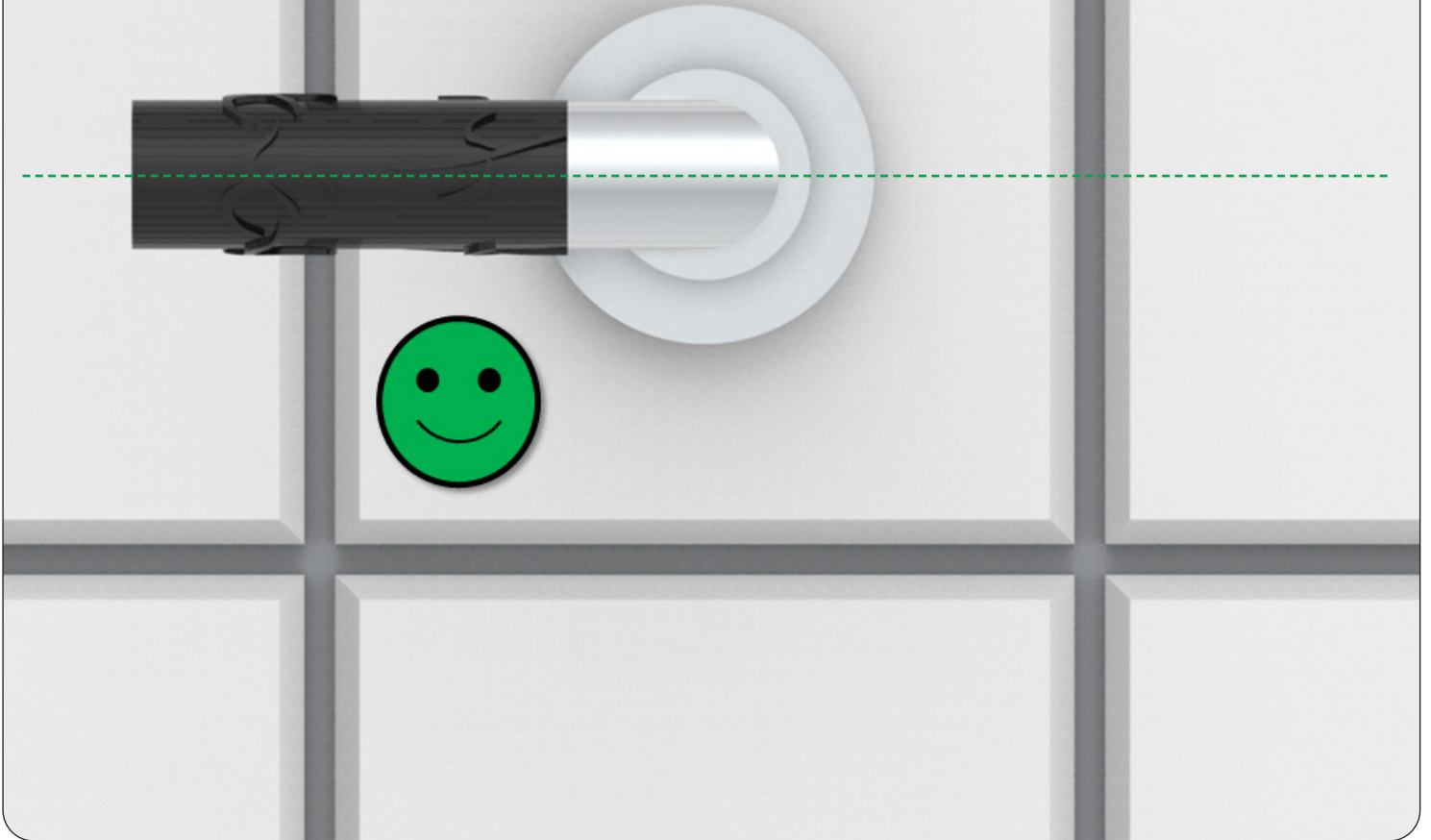

Répéter l'opération jusqu'à obtenir la position verticale ou horizontale (19 positions possibles)

Repeat the procedure until you obtain the right vertical or horizontal position (19 possible positions)

重复操作，直到达到垂直或水平位置（可能有 19 个位置）

Wiederholen Sie den Vorgang, bis die vertikale oder horizontale Position erreicht ist (19 mögliche Positionen)

Repetir la operación hasta obtener la posición vertical u horizontal (19 posiciones posibles)

Ripetere l'operazione fino al raggiungimento della posizione verticale o orizzontale (sono possibili 19 posizioni)

Herhaal de handeling totdat u de verticale of horizontale positie bereikt (19 mogelijke posities)

Повторяйте операцию, пока не достигнете вертикального или горизонтального положения (возможны 19 положений)

كزّر العملية إلى غاية الحصول على الوضع العمودي أو الأفقي (٩١ وضعاً ممكناً)

THG[®]
P A R I S