



APPROVED PRODUCT
CF5503



Consort Architectural Hardware LTD
25-31 Lower Loveday Street,
Birmingham, B193SB, United Kingdom
2812-CPR-AD5429 20
EN 1154:1996+A1:2002 3 8 1/2 1 1 3

RICHMOND

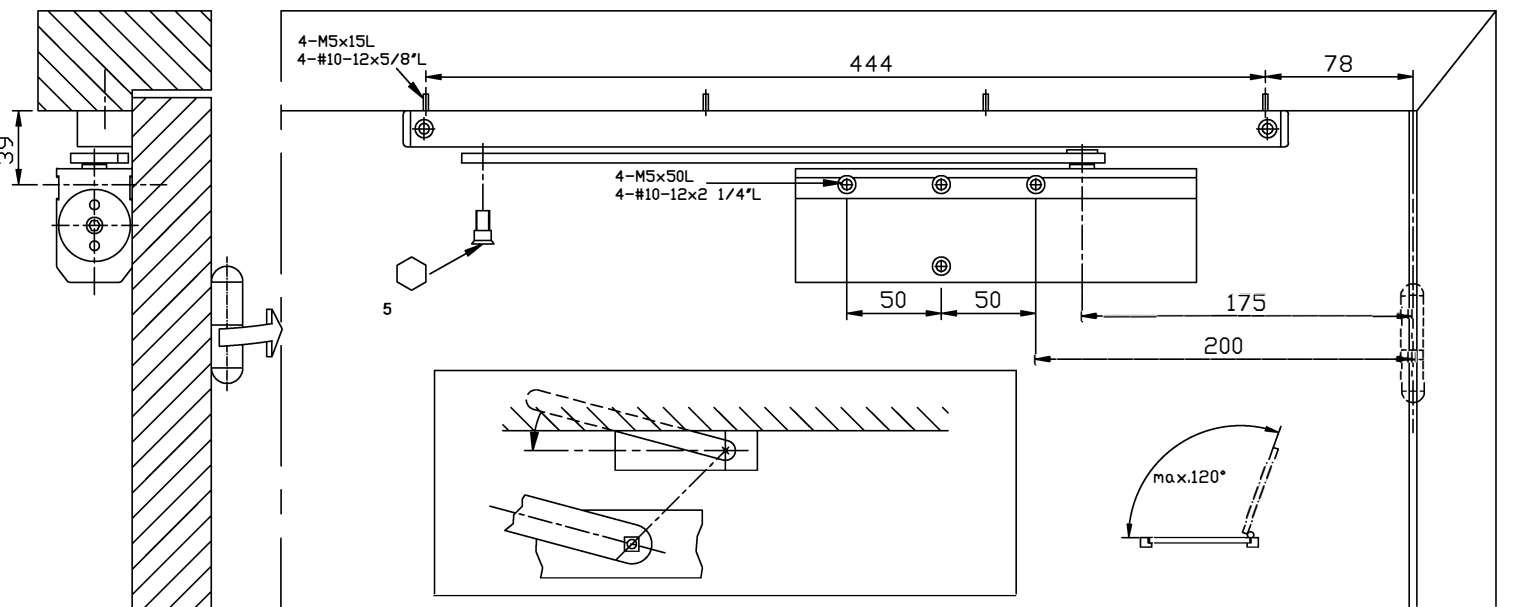
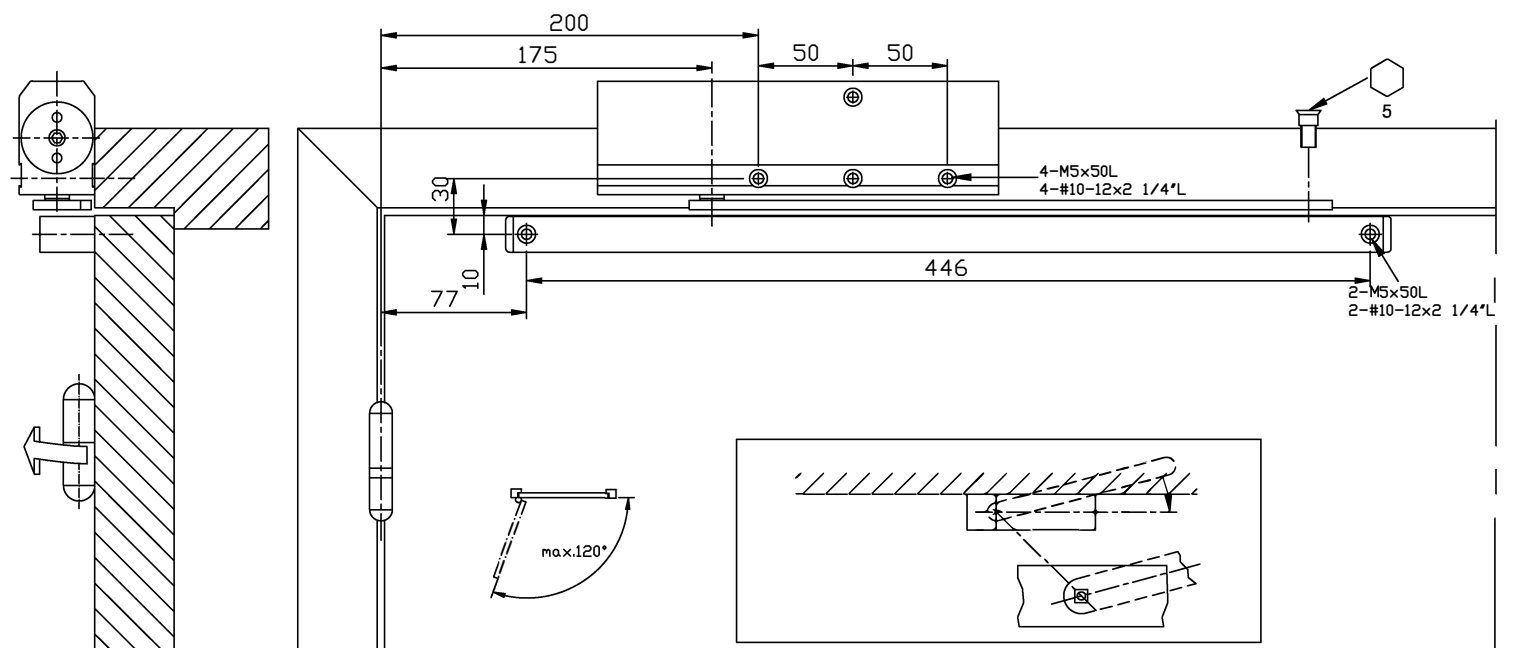
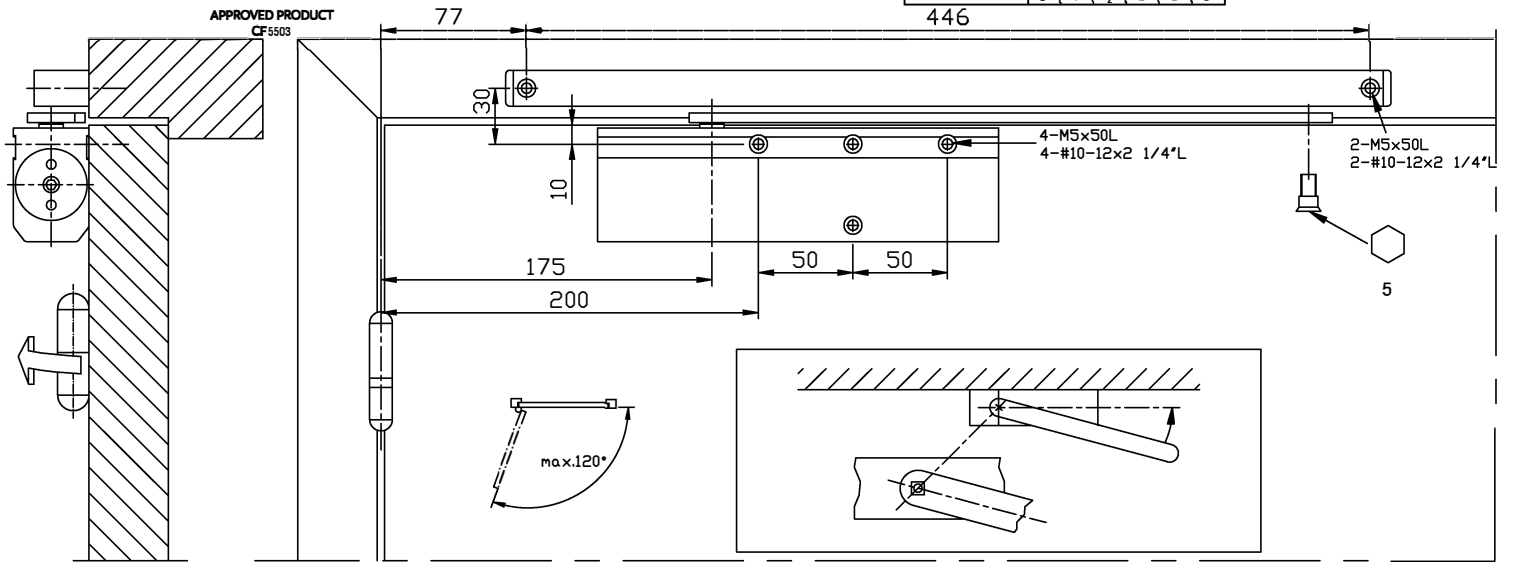

SPRING POWER ADJUSTMENT

ADJUST CLOSER SIZE ACCORDING TO CHART ON THE RIGHT

CC : COUNTERCLOCKWISE

C : CLOCKWISE

: FACTORY PRE-SET

2-5 MODEL		
NO.OF TURNS	DIRECTION	SIZE
3	CC	2
#0	-	3
4	C	4
7	C	5

Maintenance: Check and adjust the closing and latching speeds when necessary. Periodically apply a little light machine oil to the moving joints of the arm and slide track. Quarterly check that the fixings of the closer body and the slide track are tight. NB: Well-maintained hinges will assist performance.