

RICHMOND

PREMIUM DEAD LOCK : RIC-CH7282F

INSTRUCTION

	Consort Architectural Hardware Ltd. Unit 3, Radial Park Solihull Parkway Birmingham Business Park B37 7WN United Kingdom	 APPROVED PRODUCT CF 6053
	BS EN 12209:2003	
	NO DANGEROUS SUBSTANCES	
CH7282F & CH7282FR	Product Classification 3,X,8,1,0,G,2,B,A,0,0	
Year of Marking:21	Classification Body Ref No:2812	

BEFORE FITTING PLEASE NOTE:

When using templates which suit multiple lock case types, please check which preparations are required according to the lock type being fitted - **NOT ALL THE HOLES MAY BE REQUIRED.**

Fire Door Installation:

Please note that when installing to a fire rated door to EN 1634-1, the lock case must be fitted with the appropriate thick intumescent protection corresponding to the fire ratings. Sufficient space should be allocated during door preparation to accommodate this requirement.

Installation Instructions:

1. Mark on the door the vertical centreline and the required centreline of the spindle/lever handle on both sides of the door.
2. Carefully position the lock case as shown aligning the centrelines and mark around the lock case on the door edge.
3. Mortise out the door to allow the lock case to slide in ensuring a good fit but not too tight.
4. With the lock case inserted into the door, mark around the forend. Remove the lock and prepare a recess 3.5mm deep to allow the lock forend and its cover plate to sit flush with the door edge.
5. Place or tape the relevant template in position on the door face aligning the spindle centreline with the markings on the door.
Mark the position of the spindle and cylinder and any through fixing holes required making sure to use the correct template markings for the lock being fitted.
You can repeat this on the other side of the door.

Tools required:

- Pencil
- Screwdriver (No.2 Pozidrive)
- Drill with 8mm & 20mm drill bits
- Chisel

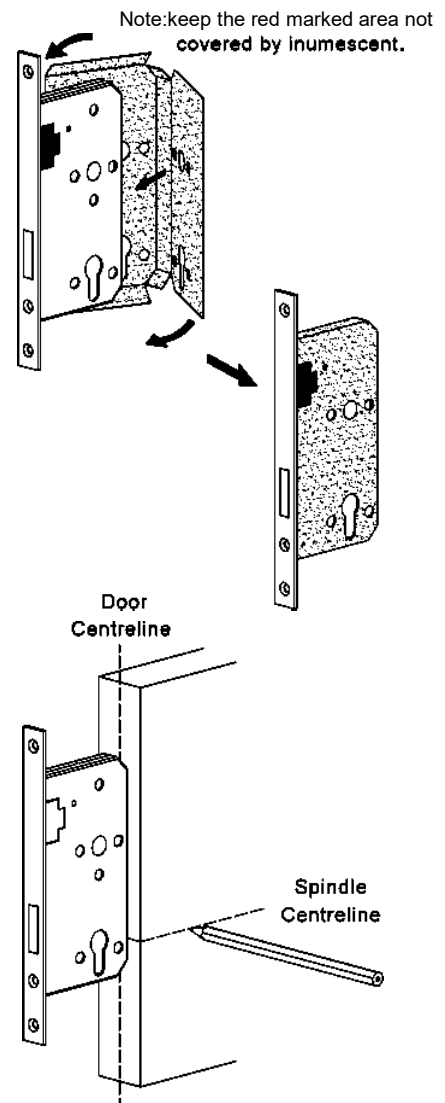

6. Drill all required holes from both sides of the door through into the mortice.
7. Remove all debris from the mortice and fix the lock case into position with the screws provided.
8. The forend cover plate can be fitted once the cylinder (if applicable) has been installed.

CHECK THE LOCK OPERATES CORRECTLY

Installation of Strike Plate:

9. Close the door up to the frame and mark the position of the latch and/or bolt (depending on the lock being fitted) onto the frame. Transfer the lines around to the inside edge of the frame [a].
10. Measure the distance [b] from the closing face of the door to the edge of the latch/bolt and mark this distance onto the frame so that the latching/locking positions are accurately transferred to the frame.
11. Position the strike plate on the frame so that the markings of the latch/bolt position can be seen through the apertures on the strike plate.
12. Mortice out the frame for the latch and/or bolt and recess the frame so that the strike plate sits flush with the frame. The screw holes may need to be counterbored to allow the strike plate to lie flush.

PLEASE NOTE, THE DEADBOLT HAS A THROW OF 20MM. ENSURE SUFFICIENT MATERIAL IS REMOVED FROM THE FRAME TO ALLOW THE BOLT TO THROW TO ITS FULL EXTENT INTO THE FRAME.

13. Fit strike plate with the screws provided.
14. Fit furniture as required and check the operation of the lock case.

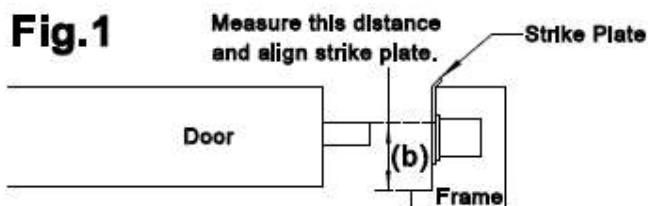
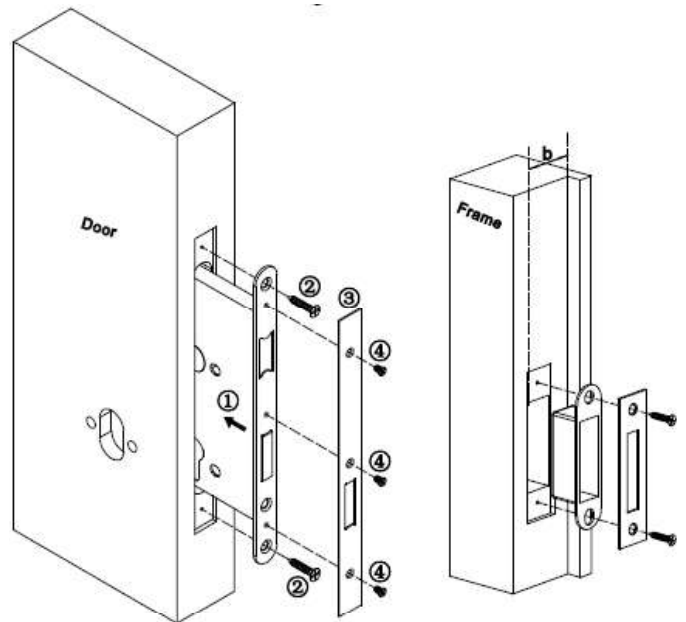
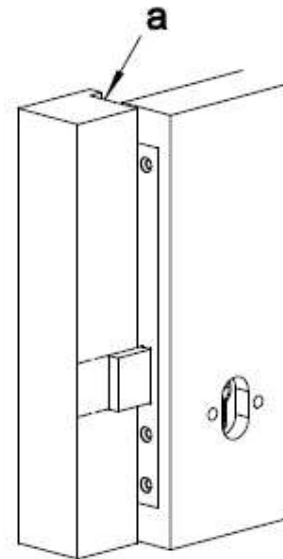
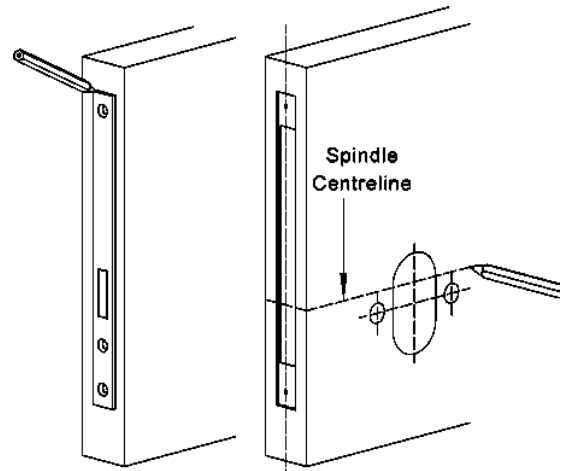

❖ NOT TO SCALE ❖

Template for cut out with no
intumescent

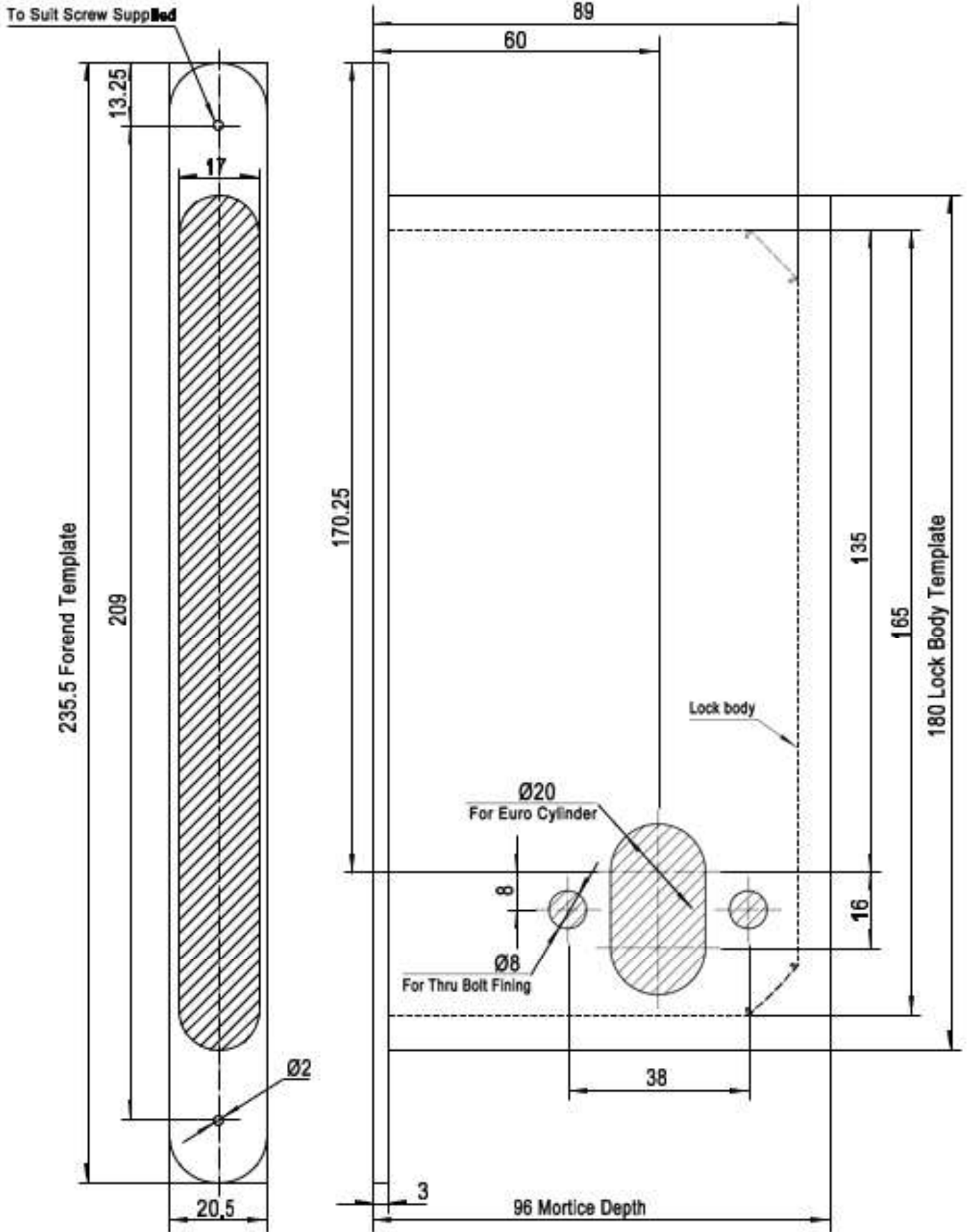

❖ NOT TO SCALE ❖

Template for cut out with 1mm
intumescent

To Suit Screw Supplied

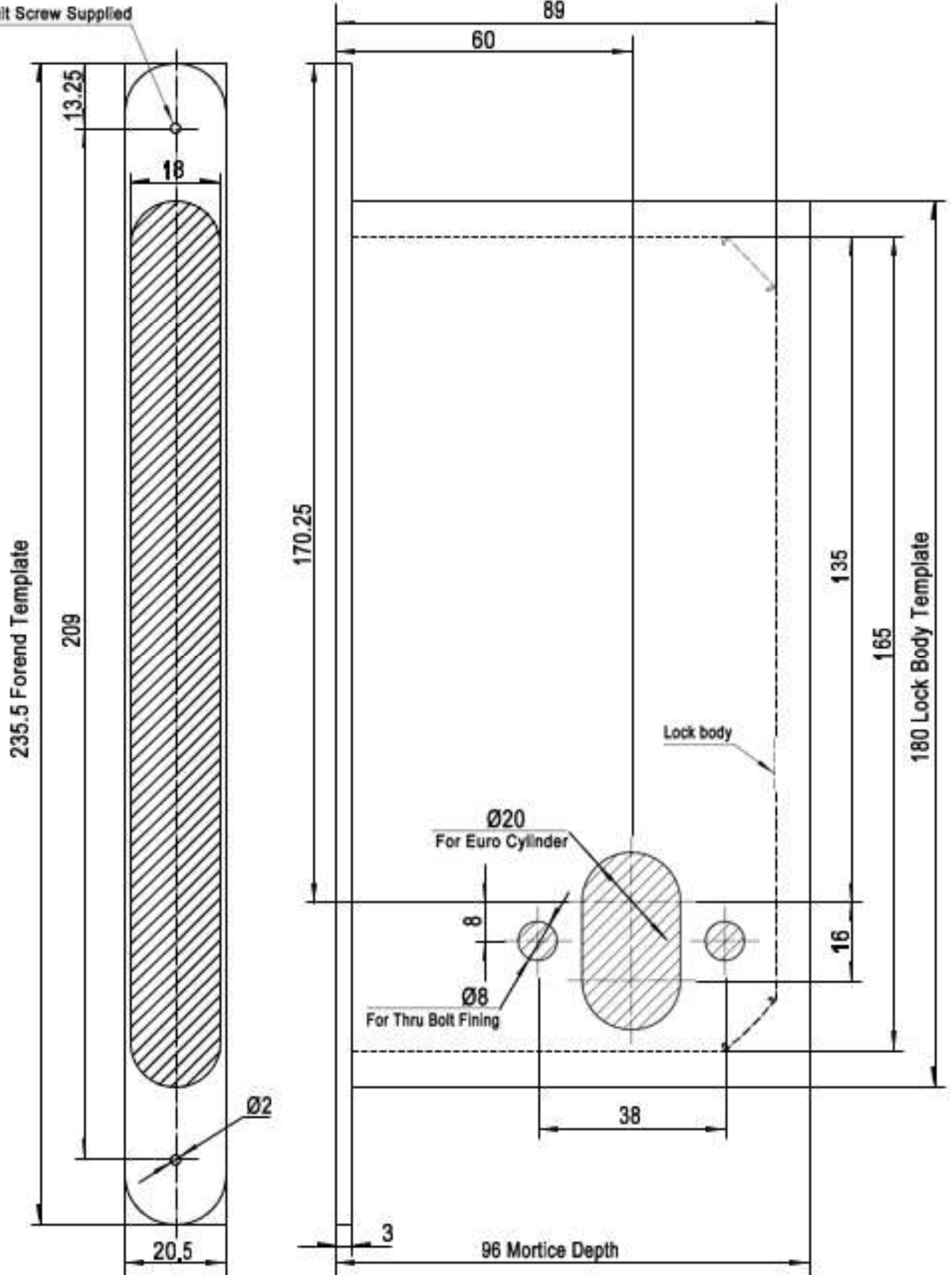

❖ NOT TO SCALE ❖

Template for cut out with 2mm
intumescent

